



# Space Time Adaptive Processing for Radio Frequency Identification Smart Antenna Systems

*Rolando Guerra Gómez, Sheila Luisa Viqueira Bernal, Francisco Marante Rizo.*

## ABSTRACT

Smart antenna has been recognized as a promising technology to improve wireless communications. Interference suppression, power consumption reduction and high data rates support are some of its advantages. Radio frequency identification (RFID) demands power efficiency, better reading ranges, tracking tag signals and interference mitigation. In this paper, a smart antenna processing for RFID systems is implemented. Space Time adaptive processing (STAP) with digital down converters, IQ beamformer and complex least mean square (LMS) algorithm has been designed and validated on Xilinx z7020 field programmable gate array (FPGA) platform. The system exhibits good performance in term of bit error rate (BER) when signal to noise plus interference ratio (SNIR) is over 1 dB with signal to noise ratio (SNR) of 7 dB environments.

**Key Words:** Smart antenna; RFID; STAP; complex LMS algorithm; IQ beamformer; DDC.

## 1. –INTRODUCTION

Researchers have studied the antennas since they are main part of wireless communication systems [1,2]. With the increasing demand of higher data rate, better coverage, capacity, reducing power consumption, interference suppression and multipath mitigation; more efficient radiation systems are needed. Smart antennas give a promising future in order to achieve the goals above mentioned by introducing a space division multiple access (SDMA) in new generations of wireless networks. This medium access technique provides spatial filtering to face high level of interference environments.

There are three kinds of smart antennas: switching beam antennas, phased arrays and adaptive smart antennas (ASA). The former can focus the radiation pattern to a finite number of angles, switching between lobes in order to maximize the signal-to-noise power ratio (SNR). The second can adjust dynamically the feeding progressive phase of the array cells for steering the main lobe, covering a continuous range of angles [3]. The last combines array antenna and digital signal processing theory to make a smarter system.

ASA, by means of an adaptive algorithm, modifies the amplitude and phase of the signal at each unit cell of the array for steering the main lobe to signal of interest (SOI) and nulls to interference signals (IS) [4], as shown in Figure 1. Different Adaptive algorithms have been used for digital beamforming such as least mean square (LMS), normalized least mean square (NLMS) and recursive least square (RLS) [5]. These algorithms are no blind because they need prior information of the SOI, which is normally used as reference or training signal. Some blind algorithms such as constant modulus algorithm, have been proposed mainly in systems where info about SOI is hard to be obtained [6].

Authors have used LMS adaptive algorithm in smart antenna analysis and designs [5,7–11] by its robustness, simplicity and low computational cost. Comparative studies between LMS and others adaptive algorithms have been reported on literature [5,7,10,11].

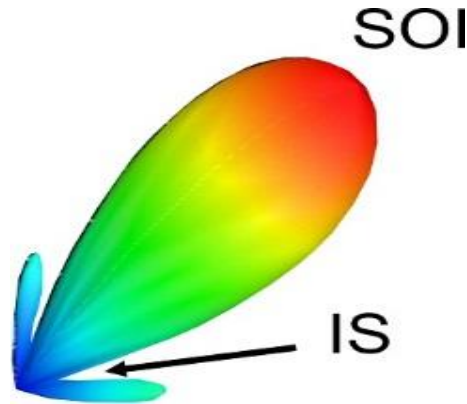

**Figure 1**  
**Radiation Pattern of Adaptive Smart Antenna**

In [5] LMS and NLMS were compared based on normalized array factor and mean square error (MSE) for mobile communications. They have high resolution for beam formation, but LMS has better performance minimizing the MSE. LMS, RLS and SMI were studied in [7] founding the former has minor side lobe level and major main beam level to side beam level ratio. However, its slow convergence presents problems tracking signals in high velocity environments [11].

Radio Frequency Identification (RFID) technology uses radio frequency signals to identify tagged objects. It consists of RFID readers and tags, which are attached to single objects. The data code contained in the tag allows the identification of the object. Improvement RFID systems are the subject of much research [12–33].

Capabilities of these systems as automatic identification, real time location tracking and sensing the surrounding result in an increase of RFID application areas: health care, traffic, airports, banks, schools, access control, security, libraries and smart inventory [13,16,25].

However, RFID applications demand to eliminate limitations as cost, interferences, collisions and energy efficiency [13,16,33]. Anti-collisions algorithms based on time division multiple access (TDMA) have been studied in recent years. In order to improve energy efficiency a power optimization waveform was proposed in [30] and authors have designed array antennas [15,19,20,22,23,26,32]. Smart antennas have been used for more efficiency power allocation, reducing the level of interference and achieving more coverage area for readers [19,20,32].

This work is in the context of enhancing the interrogation range, radiation performance, interferences mitigation and reduce the number of RFID readers. For accomplishing this goal a space time adaptive processing (STAP) is used. Unlike the designs reported in the literature, a non-blind LMS algorithm is implemented to achieve a low computational cost design. A general diagram of this kind of readers is shown in Figure 2. The use of IQ beamformer and digital down converters (DDCs) allow replacing the traditional super-heterodyne receiver by low-IF sampling down conversion.

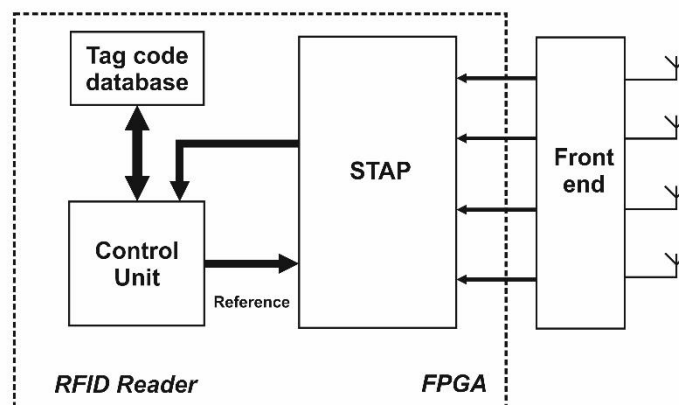

**Figure 2**  
**Proposed RFID Reader architecture with Adaptive Processing.**

This paper is organized as: In section 2, the mathematical model for the proposed system is described. Section 3 presents a simple channel implementation and analysis of LMS algorithm. Section 4 exhibits the proposed STAP design. Section 5 shows the system performance. In section 6, a resume of resource consumption on FPGA z7020 is presented. Section 7 concludes this paper.

## 2. -MATHEMATICAL ADAPTIVE SMART ANTENNA MODELING

Figure 3 shows a block diagram of an ASA system with STAP, which is composed by a uniform linear array (ULA), front-ends for each antenna array cell, analog-to-digital converts (A/D) and a digital signal processor unit (DSP). The ULA collects incoming signals from different angles. These signals pass through front-ends, that include low noise amplifier, RF filters and mixers, with the goal to down convert them from radiofrequency (RF) to intermediate frequency (IF). After this process, A/Ds digitize these IF signals, which are called snapshots in this paper.

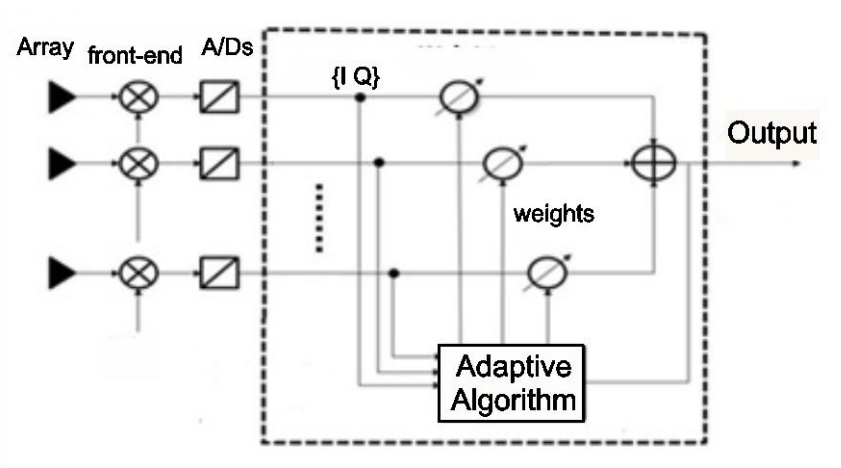

Figure 3  
 General Scheme of Smart Antenna Systems.

DSP block (dotted line in Figure 3) has three functions in this paper: splitting incoming IF signals into in-phase ( $I$ ) and quadrature ( $Q$ ) components, computing, using LMS adaptive algorithm, weight complex vectors and forming the output of the STAP system. The full process will be described mathematically.

### 2.1. -SIGNAL MODEL

The STAP has to be able to process multiple channels. Matrix notation is a useful math tool for this kind of systems. The output of the STAP becomes in (1).

$$\begin{aligned}
 Y &= W^H X \\
 W &= [w_1 \ w_2 \ w_3 \ \dots \ w_L]^T \\
 X &= [x_1 \ x_2 \ x_3 \ \dots \ x_L]^T
 \end{aligned} \tag{1}$$

in which,  $W$  is a complex weight vector,  $X$  is the vector of snapshots,  $L$  is the number of elements of the ULA and superscripts T, H denote transposition and complex conjugate transposition, respectively.

The snapshot vector and the complex weight vector could be expressed by means of its in-phase ( $I$ ) and quadrature ( $Q$ ) components as in (3) and (4) respectively:

$$X = (I + jQ)e^{-jw_i n} \quad (3)$$

$$W = W_I + jW_Q \quad (4)$$

where  $w_i$  is an intermediate digital frequency and  $n$  is the sample time. Substituting (3) and (4) in (1) a baseband version of the output is obtained as (5):

$$Y = (W_I I + W_Q Q) + j(W_I Q - W_Q I) \quad (5)$$

In order to achieve the IQ components and the conversion to baseband a Digital Down Converter designed in [4] were used. The adaptive algorithm computes the optimal  $W$  vector for beamforming.

## 2.2. -ADAPTIVE LMS ALGORITHM MODEL

LMS algorithm is a type of no blind algorithm, because it uses a reference signal (RS) for tracking the SOI and steering nulls to the IS. The ASA has to be able to obtain the RS before tracking begins. The systems uses a prior training period to transmit the RS to ASA. LMS minimizes the MSE using an iterative process and upgrades the weight complex vector by moving in the opposite direction of the gradient [3,7], see (6).

$$w[n + 1] = w[n] - \frac{\mu}{2} \nabla[e[n]^2] \quad (6)$$

$$e[n] = d[n] - w^H[n]x[n]$$

where  $\mu$  is the step-size and  $e[n]$  is the error between the output and the reference signal ( $d[n]$ ). After a mathematical process detailed in [3,7,34] the weight complex vector is upgraded by (7).

$$w[n + 1] = w[n] + \mu x[n]e^*[n] \quad (7)$$

The step-size controls the convergence of the algorithm. High values of  $\mu$  produce fast convergence however, the probability of instability grows, the choice of  $\mu$  is a tradeoff between velocity and stability for what it has to satisfy (8).

$$0 < \mu \leq \frac{1}{2\lambda_{max}} \quad (8)$$

Where  $\lambda_{max}$  is the maximum eigenvalue of the incoming signal correlation matrix [34].

## 3. – SINGLE CHANNEL LMS DESIGN IN SYSTEM GENERATOR

A single channel LMS algorithm is designed using MatLab and System Generator in order to check on FPGA the theory described in section. Figure 4 presents the block diagram of the LMS algorithm.

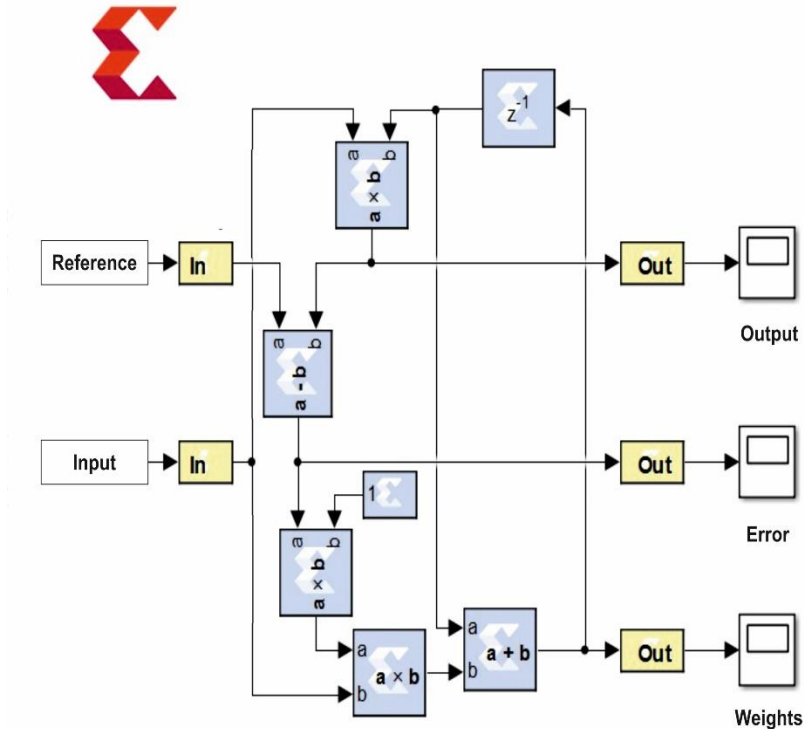

Figure 4

**LMS algorithm design using System Generator and MatLab.**

In and Out blocks are interfaces between MatLab and System Generator. This allows generating input signals for exciting the algorithm and analyzing its response using MatLab. The LMS algorithm is inside of In and Out blocks on system generator environment. Table 1 summarizes the test parameters used.

**Table 1**  
**System and signal parameters.**

Parameter	Value
Sample frequency ( $f_s$ )	4 kHz
Input and Reference frequency ( $f_i$ )	0.5 kHz
Input Signal	$2\sin(2\pi f_i t)$
Reference Signal	$\sin(2\pi f_i t)$

Figure 5 exhibits the performance of the LMS algorithm, when the step size is  $\mu = 0.08$ ,  $\mu = 0.16$  and  $\mu = 0.32$ . Figures 5 a) b) validate that  $\mu$  controls the convergence characteristic of the LMS algorithm. Higher values of  $\mu$  produce fast convergence. The weights obtained in Figure 5 c) are expected because they tend to the scale factor between reference and input signal ( $w = 0.5$ ).

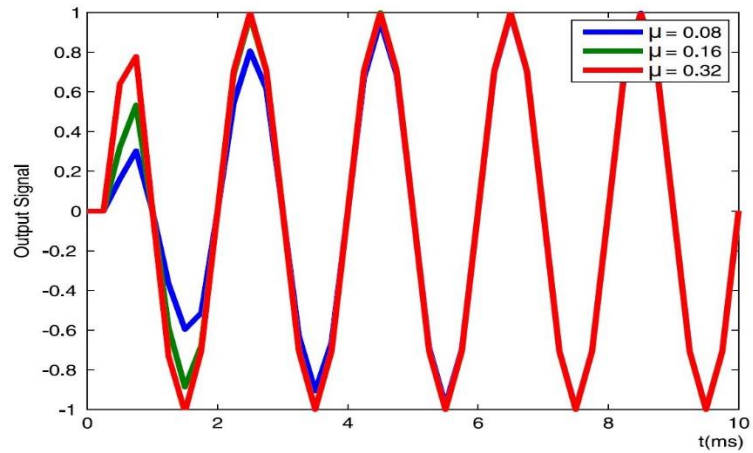

a)

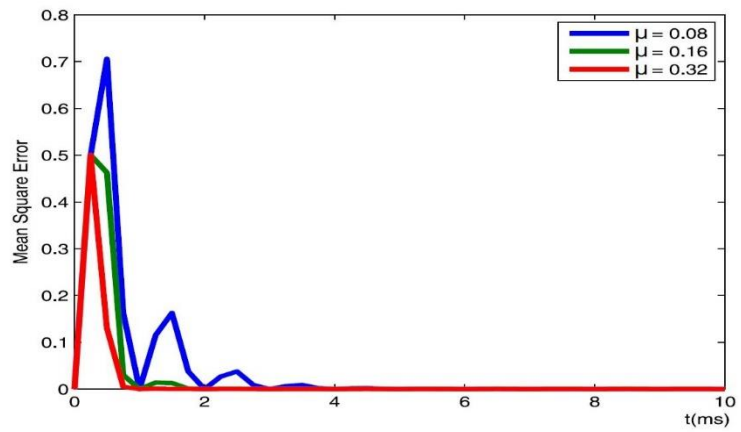

b)

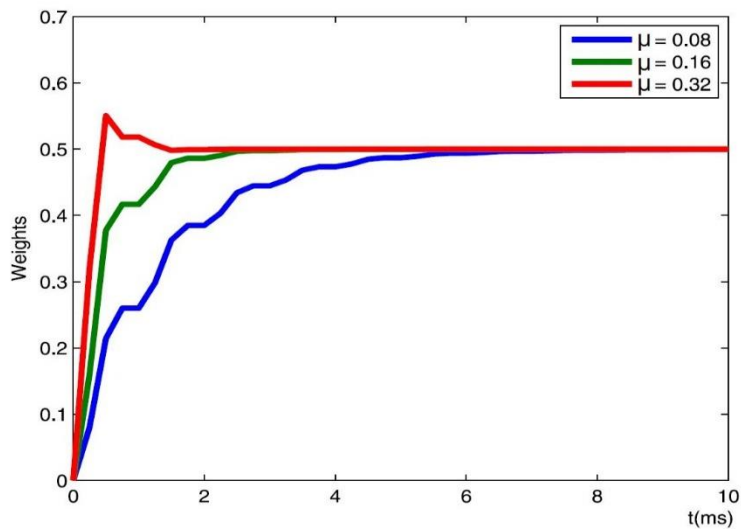

c)

Figure 5

Single channel LMS algorithm (a) Output Signal (b) Mean Square Error (MSE) (c) Weights.

## 4. – SPACE TIME ADAPTIVE PROCESSING STRUCTURE

The proposed design in this paper consists in a STAP marked on the Figure 6 with dotted line and in Figure 2. The system is designed using System Generator and MatLab and proven on Xilinx FPGA z7020. In order to highlight, the STAP design has been divided in three functional blocks. The former is a Digital Down Converter (DDC), which has been detailed in [4] and to achieve the IQ components of multichannel signals from an ULA of four elements is used. The second is a digital IQ beamformer, which is able to weight the incoming signal from each array cell using the mentioned IQ components and a complex weight vector. The last block is able to compute this complex weight vector by means of a LMS adaptive algorithm, which has IQ components and reference signal as input signals. Figure 6 presents the block diagram of the proposed system.

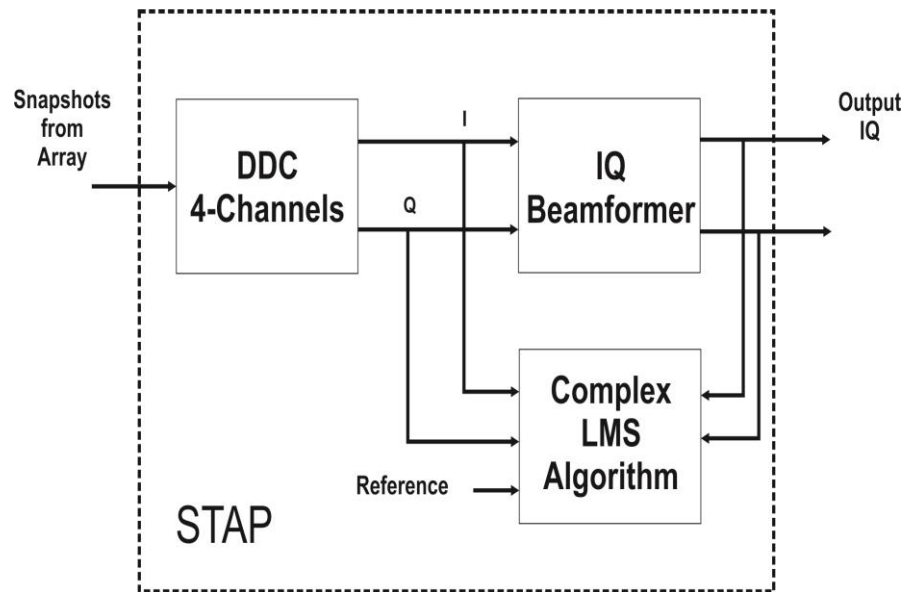

Figure 6

Block Diagram of the proposed STAP system.

Figure 7 shows the IQ beamformer block. Where IQ components and complex weight vector are input signals. This block use Complex Multiplier 3.0, CMult, Adders and Cast System Generator blocks to achieve the STAP output by means of (5).

The LMS adaptive algorithm has to be able to process the IQ components and the STAP output for computing a complex weight vector. In order to satisfy the above-mentioned goal a complex LMS Algorithm was implemented, see Figure 8. This LMS design uses Adders, Complex Multiplier 3.0, Cast, Constant and Delay blocks to compute the complex weight vector described by the equation (7)

For analyzing the performance of the proposed STAP, a Quadrature Phase Shift keying (QPSK) transmitter was designed on MatLab environment. Figure 9 depicts the scheme of the transmitter, the propagation channel and the ULA used to generate the snapshots for exciting the designed system.

The transmitter generates the SOI signal by means of a QPSK modulator with gray codification and an Up-Converter, the propagation channel allows adding Additive White Gaussian Noise (AWGN) and interferences or jamming signals, the ULA block simulates an ULA, which computes the snapshots.

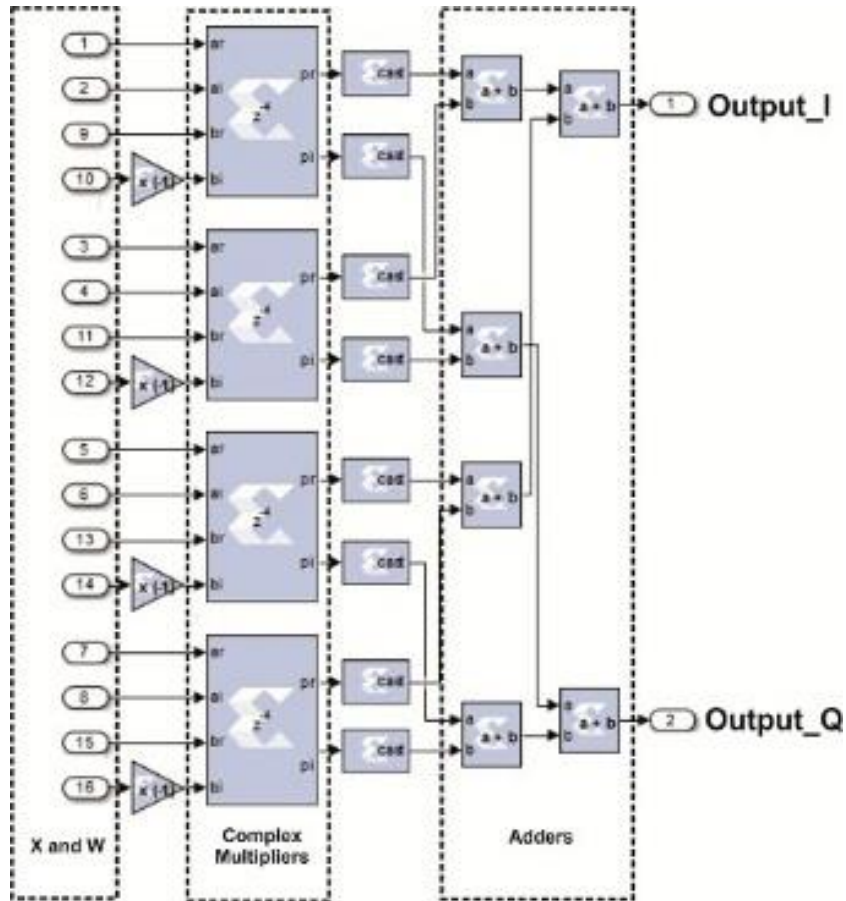

Figure 7  
 IQ beamformer.

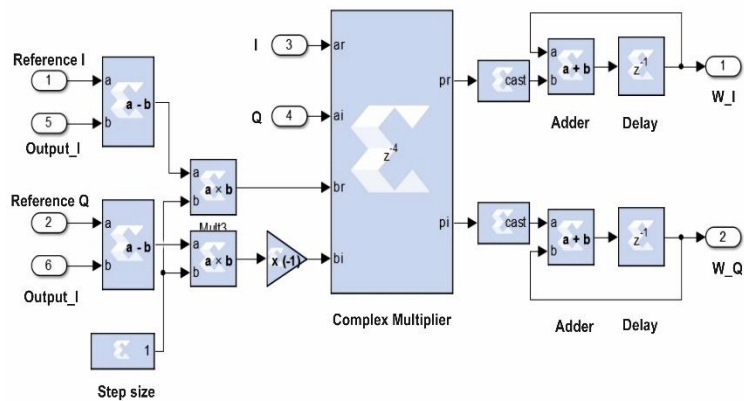

Figure 8  
 Complex LMS adaptive algorithm.



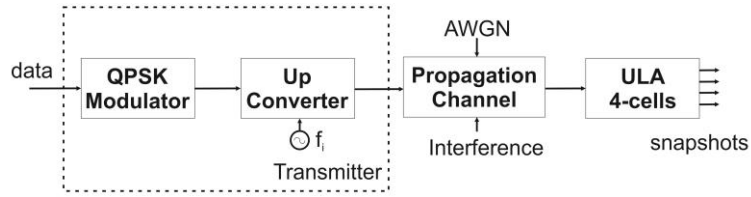

Figure 9

Scheme of snapshots generation.

The parameters used in snapshots generation are summarized in Table 2.

Table 2  
 System and signal parameters.

Parameter	Value
data	tag code (0-3)
Symbol Rate ( $R_s$ )	2 kbps
Sample frequency ( $f_s$ )	4 MHz
Intermediate frequency ( $f_i$ )	0.5 MHz
Interference Signal	$A_{is} \sin(2\pi f_{is} t)$
Interference frequency ( $f_{is}$ )	507 kHz
ULA elements spacing	$0.5 \lambda$
ULA elements	Isotropic
step size	0.004

## 5. – PERFORMANCE ANALYSIS

The DDCs used in the proposed design present good performance ( $BER = 0$ ) processing QPSK signals with signal to noise ratio (SNR) over 5.5 dB. For this reason, the noise power ( $P_n$ ) is fixed in order to obtain upper values of SNR. The response of the system, to an RFID tag and an interference placed in azimuth angles  $\phi_{soi} = -30^\circ$  and  $\phi_{soi} = 60^\circ$  respectively, with ( $A_{is} = 0.5$ ) in absence of noise, is shown in Figure 10.

The symbol transitions demand a new convergence of the algorithm, result in glitches and oscillations at the beginning of the symbols. This situation is main in the design of the system because the oscillation time (convergence speed) depend of the step size and the symbol period must be greater than the needed time by the algorithm to converge ( $T_c$ ). In order to sample at center of the symbol period at the receiver terminal, the system must satisfy the convergence condition  $T_s \geq 2 T_c$ , where  $T_c$  is the symbol period.

The step response is shown in Figure 11. The number of samples needed to converge is 300 approximately. The choice of  $R_s$ ,  $f_s$  and  $\mu$  must be a tradeoff in order to satisfy the convergence conditions. Figure 12 shows the normalized radiation pattern generated, where the main lobe is steered to SOI and the IS mitigated.

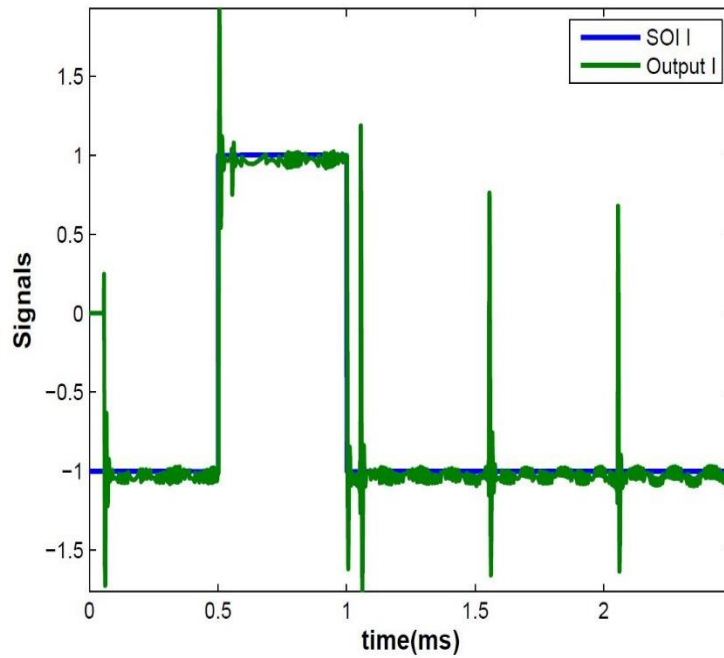

a)

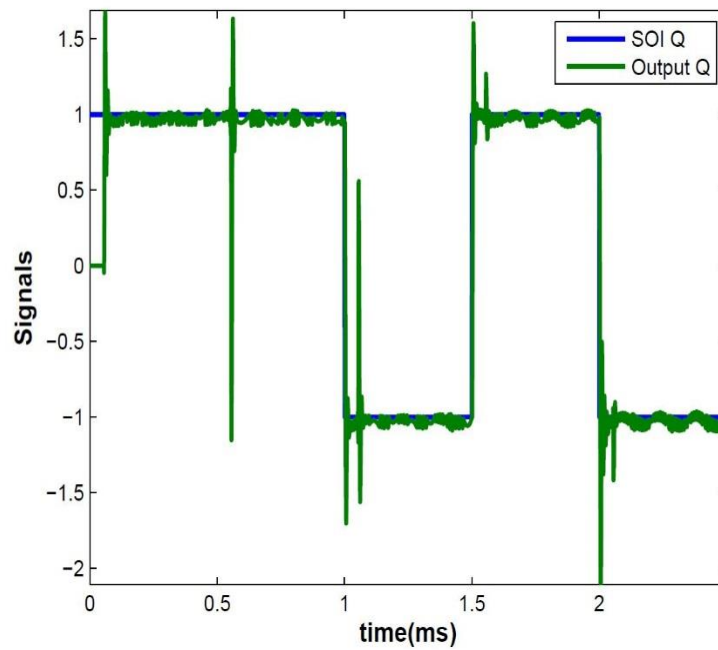

b)

Figure 10

SOI and Output of scenario 1: (a) I components, (b) Q components.

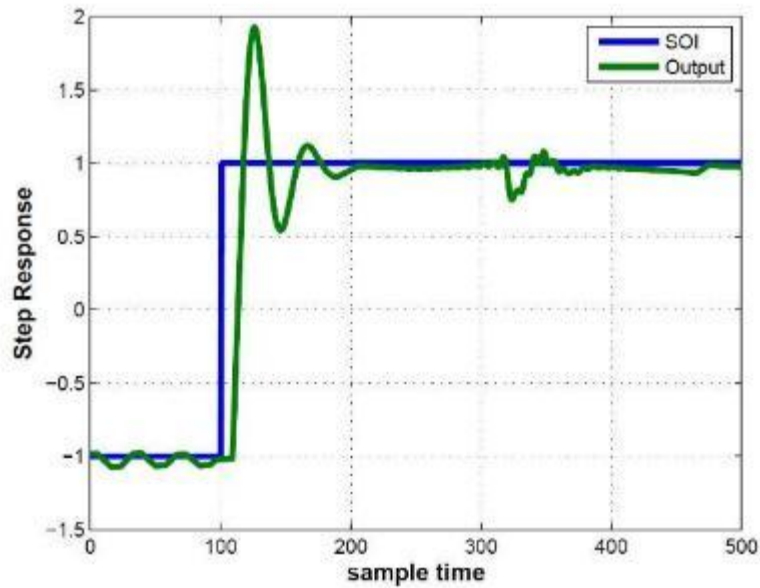

Figure 11  
 Step Response ( $A_{is} = 0.5$ ).

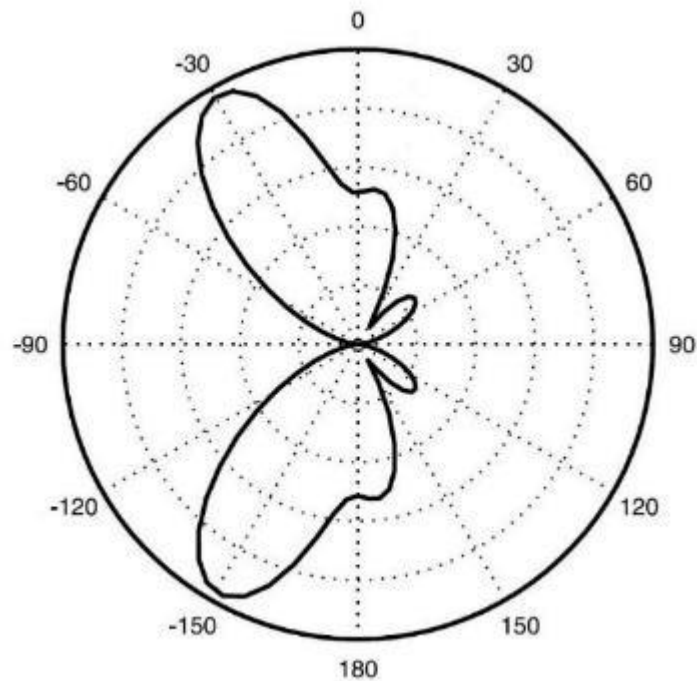
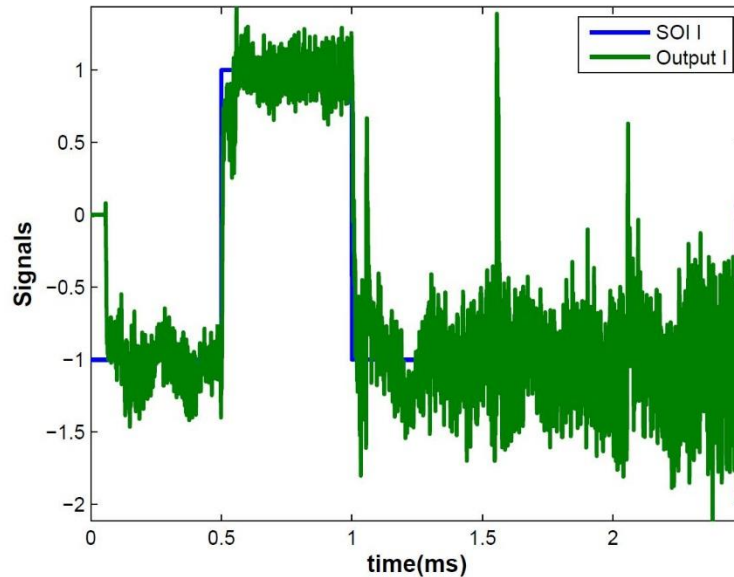

Figure 12  
 Normalized Radiation Pattern.

The capacity of the proposed STAP system tracking RFID tags and mitigating interferences is measured in sceneries with different signal to interference plus noise ratios (SINR). In the presented system, the interference amplitude controls the SNIR values for given values of SNR by means of (9).

$$A_{is} = \sqrt{2P_n \left[ \frac{SNR}{SINR} - 1 \right]} \quad (9)$$

Figure 13 shows the response of the system with SINR = 1 dB and SNR = 7 dB, where noise and accepted interference signal are added to the SOIs in the IQ output signals. Upper levels of interference produce high values of BER in this SNR environment.



a)

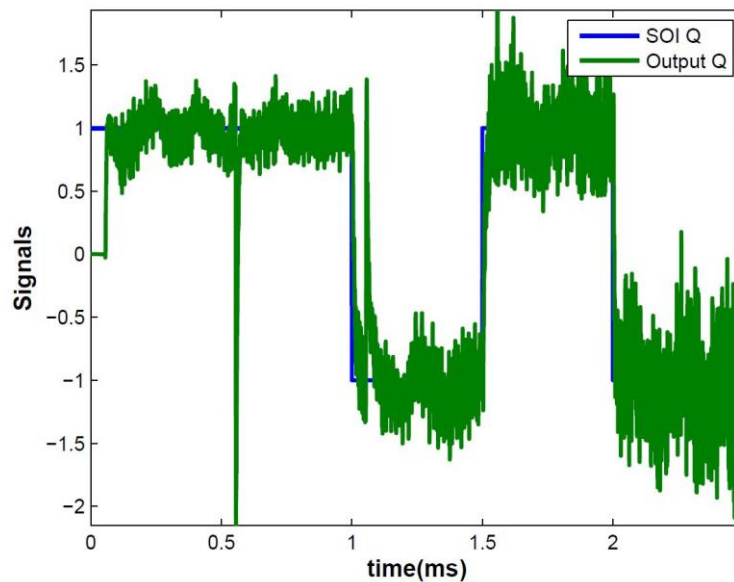

b)

Figure 13

SOI and Output (SNR = 7 dB; SINR = 1 dB ( $A_{IS} = 1.24$ )): (a) I components, (b) Q components.

## 6. – RESOURCE CONSUMPTION

The performance of the STAP described in this paper is validated using the co-simulation hardware tool available on System Generator environment. This tool allows generating the VHDL code for Xilinx FPGAs and simulating the system in Software

and Hardware at the same time. The results were obtained on Xilinx z7020 platform. Table 3 summarizes the available resources and the resources consumption by the proposed space-time adaptive processing system.

**Table 3**  
**Resource consumption on Xilinx z7020 platform.**

Functional Blocks	Resource Consumption.	Total resources
Mult/DSP48s	65	220
IOBs	2	200
RAMBs	2	140
Slices	400	13300
Slice registers	609	106400
Slice LUTs	1016	53200
LUT-Flip Flop	3147	226660

## 7. – CONCLUSIONS

This paper presents an implementation of a smart antenna processing for RFID applications. Space time adaptive processing with Complex LMS, IQ beamforming and Digital Down Converters is designed for an UHF RFID smart antenna systems. The proposed design in addition of improving the reading range, mitigate interference and reduce the number of readers needed is a simpler design, more robust and lower computational. Furthermore, it has good performance tracking RFID tag signals in environment when information about the incoming signals is known as smart inventory applications. Consumption resources on Xilinx FPGA z7020 allow completing the RFID Reader design on this platform.

## REFERENCES

1. Hidalgo A.E., Rizo F.M. Aumento del Ancho de Banda en Antenas de Microcintas a 2,4GHz con Inserción de Metamateriales. Revista Ingeniería Electrónica, Automática y Comunicaciones, RIELAC, ISSN 1815-5928. 2018;39(1):1–15. Available from: <http://rielac.cujae.edu.cu/index.php/riec/article/view/455>
2. Carcasés F.A.F., Sansón D.A.R., Ávila D.R., Rizo F.R.M. Diseño de una antena Logarítmica Periódica Impresa en la banda de 470-890 MHz. Revista Ingeniería Electrónica, Automática y Comunicaciones, RIELAC, ISSN 1815-5928. 2015;36(2):53–61. Available from <http://rielac.cujae.edu.cu/index.php/riec/article/view/283>
3. Gholami R., Mehrpourberney H., Zakeri B. UWB phased array antennas for high resolution radars, 2013 International Symposium on Electromagnetic Theory. Hiroshima; Japan; 2013. p. 532–535. Available from: <http://ieeexplore.ieee.org/stamp/stamp.jsp?tp=&arnumber=6565794&isnumber=6565651>
4. Bernal S.L.V., Velazquez Y.O., Gómez R.G., Rizo F.M. Convertidor Digital de Bajada para Antenas Inteligentes. Revista Ingeniería Electrónica, Automática y Comunicaciones, RIELAC, ISSN 1815-5928. 2017;38(3):76–84. Available from: <http://rielac.cujae.edu.cu/index.php/riec/article/view/461>
5. Yasin M., Pervez A., Valiuddin. Performance Analysis of LMS and NLMS Algorithms for a Smart Antenna System. International Journal of Computer Applications, IJCA. 2010;4(9):25–32. Available from: <https://www.ijcaonline.org/archives/volume4/number9/854-1196>

6. Zhao H., Lian B., Feng J. Adaptive beamforming and phase bias compensation for GNSS receiver. *Journal of Systems Engineering and Electronics*, JSEE. 2015;26(1):10–18. Available from: <https://ieeexplore.ieee.org/document/7064074/>
7. Kitindi E.J. Capabilities of smart antenna in tracking the desired signal in wireless communication system through non-blind adaptive algorithms. *International Journal of Advanced Research in Computer and Communication Engineering*, IJARCCCE. 2015;4(2):5–9. Available from: <https://ijarccce.com/wp-content/uploads/2015/03/IJARCCCE1B.pdf>
8. Julakanti G.R., Thota K.T. A Novel Approach for Interference Suppression Using a Improved LMS Based Adaptive Beam forming Algorithm. *International Journal of Research in Science & Technology*. 2015;2(4):26–35. Available from: <https://www.ijirst.org/articles/IJIRSTV2I3036.pdf>
9. Revati J., Ashwinikumar D. Adaptive Beamforming Using LMS Algorithm. *International Journal of Research in Engineering and Technology*, IJRET. 2014;3(5):589–593. Available from: <http://www.ijret.org>
10. Senapati A., Ghatak K., Roy J.S. A Comparative Study of Adaptive Beamforming Techniques in Smart Antenna Using LMS Algorithm and Its Variants, 2015 International Conference on Computational Intelligence and Networks. Bhubaneshwar; India; 2015. p. 58–62. Available from: <https://ieeexplore.ieee.org/document/7053804/>
11. Ramakrishna, Anuradha S. Multicast Digital Beamforming Algorithms For Smart Antennas, 6th IRF International Conference. Bangalore; India; 2014. p. 128–133. Available from: <http://www.digitalxplore.org>
12. Jesus N.S., Marciano J.J.S. Enhancing the accuracy of direction-of-arrival (DoA) estimates of passive UHF RFID tag signals using adaptive filtering, 10th International Conference on Information Science, Signal Processing and their Applications. Kuala Lumpur; Malaysia; 2010. p. 169–172. Available from: <https://ieeexplore.ieee.org/document/5605550/>
13. Abdelhalim E.A., Ei-Khayat G.A. A survey on analytical approaches used in RFID based applications, 2013 International Conference on Computer Applications Technology (ICCAT). Sousse; Tunisia; 2013. p. 1–6. Available from: <https://ieeexplore.ieee.org/document/6521960/>
14. Abdulla R., Ismail W. Survey of WSN technology based reliable and efficient active RFID, 2013 IEEE 11th Malaysia International Conference on Communications (MICC). Kuala Lumpur; Malaysia; 2013. p. 116–121. Available from: <https://ieeexplore.ieee.org/document/6805810/>
15. Alami A.E., Bennani S.D. Design and simulation of RFID adaptive antenna array using microstrip technology for object detection system, 2016 International Conference on Information Technology for Organizations Development (IT4OD). Fez; Morocco; 2016. p. 1–5. Available from: <https://ieeexplore.ieee.org/document/7479268/>
16. Anjum S.S., Noor R.M., Anisi M.H., Ahmady I.B., Othman F., Alam M. Energy Management in RFID-Sensor Networks: Taxonomy and Challenges. *IEEE Internet of Things Journal*, IJOT. 2017;4(99):1–1. Available from: <https://ieeexplore.ieee.org/document/7982625/>
17. Boryssenko A., Boryssenko E. Antenna array design for HF RFID smart cabinet, 2011 IEEE International Conference on Microwaves, Communications, Antennas and Electronic Systems (COMCAS 2011). Tel Aviv; Israel; 2011. p. 1–3. Available from: <https://ieeexplore.ieee.org/document/6105875/>
18. Nepa P., Michel A., Manara G., Colella R., Catarinucci L., Tarricone L. Experimental assessment of a design criterion for RFID wearable antennas, 2017 International Applied Computational Electromagnetics Society Symposium - Italy (ACES). Florence; Italy; 2017. p. 1–3. Available from: <https://ieeexplore.ieee.org/document/7916350/>

19. Chen S., Zhong S., Yang S., Wang X. A Multiantenna RFID Reader With Blind Adaptive Beamforming. *IEEE Internet of Things Journal, IIOT*. 2016;3(6):986–996. Available from: <https://ieeexplore.ieee.org/document/7433930/>
20. Chou H.T., Lee M.Y., Yu C.T. Implementation scenario of phase array antennas with beam-scan functionality for RFID applications, 2016 10th European Conference on Antennas and Propagation (EuCAP). Davos; Switzerland; 2016. p. 1–4. Available from: <https://ieeexplore.ieee.org/document/7481528/>
21. Farris I., Felini C., Pizzi S., Merenda M., Iera A., Corte F.D. Enabling communication among smart tags in an UHF RFID Local Area Network, 2015 IEEE 2nd World Forum on Internet of Things (WF-IoT). Milan; Italy; 2015. p. 524–529. Available from: <https://ieeexplore.ieee.org/document/7389109/>
22. Hasan K., Khaliel M., El-Hadidy M., Kaiser T. Design an adaptive electronically beamsteering reflectarray antenna for RFID systems, 2015 IEEE International Symposium on Antennas and Propagation USNC/URSI National Radio Science Meeting. Vancouver, BC; Canada; 2015. p. 2157–2158. Available from: <https://ieeexplore.ieee.org/document/7305467/>
23. Khanam S., Mahbub M., Mandal A., Kaiser M.S., Mamun S.A. Improvement of RFID tag detection using smart antenna for tag based school monitoring system, 2014 International Conference on Electrical Engineering and Information Communication Technology. Dhaka; Bangladesh; 2014. p. 1–6. Available from: <https://ieeexplore.ieee.org/document/6919149/>
24. Li H., Chen Y., He Z. The Survey of RFID Attacks and Defenses, 2012 8th International Conference on Wireless Communications, Networking and Mobile Computing. Shanghai; China; 2012. p. 1–4. Available from: <https://ieeexplore.ieee.org/document/6478720/>
25. Malakar B., Roy B.K. Survey of RFID applications in railway industry, 2014 First International Conference on Automation, Control, Energy and Systems (ACES). Hooghy; India; 2014. p. 1–6. Available from: <https://ieeexplore.ieee.org/document/6807999/>
26. Michel A., Pino M.R., Nepa P. Reconfigurable Modular Antenna for NF UHF RFID Smart Point Readers. *IEEE Transactions on Antennas and Propagation*. 2017;65(2):498–506. Available from: <https://ieeexplore.ieee.org/document/7782732/>
27. Ray B., Huda S., Chowdhury M.U. Smart RFID Reader Protocol for Malware Detection, 2011 12th ACIS International Conference on Software Engineering, Artificial Intelligence, Networking and Parallel/Distributed Computing. Sydney, NSW; Australia; 2011. p. 64–69. Available from: <https://ieeexplore.ieee.org>
28. Sadikin M.F., Kyas M. Security and privacy protocol for emerging smart RFID applications, 15th IEEE/ACIS International Conference on Software Engineering, Artificial Intelligence, Networking and Parallel/Distributed Computing (SNPD). Las Vegas, NV; USA; 2014. p. 1–7. Available from: <https://ieeexplore.ieee.org/document/6888694/>
29. Swamy J.C.N., Seshachalam D., Shariff S.U. Smart RFID based Interactive Kiosk cart using wireless sensor node, 2016 International Conference on Computation System and Information Technology for Sustainable Solutions (CSITSS). Bangalore; India; 2016. p. 459–464. Available from: <https://ieeexplore.ieee.org/document/7779426/>
30. Trotter M.S., Durgin G.D. Survey of range improvement of commercial RFID tags with Power Optimized Waveforms, 2010 IEEE International Conference on RFID (IEEE RFID 2010). Orlando, FL; USA; 2010. p. 195–202. Available from: <https://ieeexplore.ieee.org/document/5467265/>
31. Sadikin M.F., Kyas M. Efficient key management system for large-scale smart RFID applications, 2015 1st International Conference on Industrial Networks and Intelligent Systems (INISCom). Tokyo; Japan; 2015. p. 126–132. Available from: <https://ieeexplore.ieee.org/document/7157833/>

32. Wei D., Hung W., Wu K.L. A real time RFID locationing system using phased array antennas for warehouse management, 2016 IEEE International Symposium on Antennas and Propagation (APSURSI). Fajardo; Puerto Rico; 2016. p. 1153–1154. Available from: <https://ieeexplore.ieee.org/document/7696284/>
33. Xie D., Qin Y., Sheng Q.Z., Xu Y. Managing Uncertainties in RFID Applications - A Survey, 2014 IEEE 11th International Conference on e-Business Engineering. Guangzhou; China; 2014. p. 220–225. Available from: <https://ieeexplore.ieee.org/document/6982083/>
34. Godara, L.C., Smart Antennas. 1era. ed. CRC PRESS. Boca Raton, London, New York, Washington D.C; 2004.

## AUTORES

**Rolando Guerra Gómez**, Ing. en Telecomunicaciones y Electrónica por la Universidad Tecnológica de la Habana José Antonio Echeverría (CUJAE). Graduado en el año 2015. [rolandoguerragomez@gmail.com](mailto:rolandoguerragomez@gmail.com) [rolando.gg@tele.cujae.edu.cu](mailto:rolando.gg@tele.cujae.edu.cu)

**Sheila Luisa Viqueira Bernal**, Ing. en Telecomunicaciones y Electrónica por la Universidad Tecnológica de la Habana José Antonio Echeverría (CUJAE). Graduada en el año 2016. [sviqueirab@gmail.com](mailto:sviqueirab@gmail.com)

**Francisco R. Marante Rizo**, Ing. en Telecomunicaciones en el año 1974 en La Universidad de La Habana y Dr. C.T en La Universidad Técnica de Praga en 1986. [marante@tele.cujae.edu.cu](mailto:marante@tele.cujae.edu.cu)



Los contenidos de la revista se distribuyen bajo una licencia Creative Commons Attribution-NonCommercial 3.0 Unported License