

**THE IMPACT OF DIGITAL INNOVATION ON ECONOMIC GROWTH**

Hisar Sirait<sup>A</sup>, Sylvia Sari Rosalina<sup>B</sup>, Erna Sari<sup>C</sup>



ARTICLE INFO	ABSTRACT
<p><b>Article history:</b></p> <p><b>Received</b> 20 February 2023</p> <p><b>Accepted</b> 26 May 2023</p>	<p><b>Purpose:</b> This study aimed to examine the impact of technology infrastructure, digital lending, and digital payments on real per capita income, public health, and education levels.</p>
<p><b>Keywords:</b></p> <p>Digital Innovation; Economic Growth; Technology Infrastructure; Financial Security; Sustainable Economic Development.</p>	<p><b>Theoretical framework:</b> This study is built on the relationship between technology infrastructure, digital lending, and digital payments and their impact on economic and social outcomes. The study draws on theories of technology adoption and diffusion, financial inclusion, and human development.</p>
	<p><b>Design/methodology/approach:</b> This study used quantitative research to examine how technology infrastructure, digital lending, and digital payments affect income, health, and education. The sample was data from 2015-2020, cleaned and analyzed using regression analysis in E-views.</p> <p><b>Findings:</b> The findings revealed that technological infrastructure has a significant positive effect on real per capita income and public health, but a negative and insignificant effect on the education level. Digital lending was insignificantly positive for real per capita income and negatively insignificant for public health and education levels. In contrast, digital payments had a positive and significant impact on the health and education levels but a negative and insignificant effect on real per capita income.</p> <p><b>Research, Practical &amp; Social implications:</b> The study suggests that governments should prioritize the development of information technology infrastructure for SMEs to increase real per capita income and public health. Furthermore, relevant laws and regulations should be improved to ensure the development of digital payments, credit investigation systems, and standardized digital payment transactions to maintain financial security and stimulate consumer demand, ultimately promoting sustainable economic development.</p> <p><b>Originality/value:</b> The originality of this study lies in its investigation of the impact of both technology infrastructure and digital finance on income, health, and education. Additionally, the study highlights the importance of addressing regulatory issues to ensure the safe and effective use of digital finance.</p> <p>Doi: <a href="https://doi.org/10.26668/businessreview/2023.v8i6.1842">https://doi.org/10.26668/businessreview/2023.v8i6.1842</a></p>

**O IMPACTO DA INOVAÇÃO DIGITAL NO CRESCIMENTO ECONÔMICO**

**RESUMO**

**Objetivo:** Este estudo teve como objetivo examinar o impacto da infraestrutura de tecnologia, empréstimos digitais e pagamentos digitais na renda real per capita, saúde pública e níveis de educação.

<sup>A</sup> PhD in Business. Professor. Institute of Business and Informatics. Indonesia.

E-mail: [hisar.sirait@kwikkianjie.ac.id](mailto:hisar.sirait@kwikkianjie.ac.id) Orcid: <https://orcid.org/0009-0008-5755-588X>

<sup>B</sup> PhD in Business. Professor. Institute of Business and Informatics. Indonesia.

E-mail: [sylvia.rosalina@kwikkianjie.ac.id](mailto:sylvia.rosalina@kwikkianjie.ac.id) Orcid: <https://orcid.org/0009-0007-4999-2804>

<sup>C</sup> PhD in Business. Professor. Institute of Business and Informatics. Indonesia.

E-mail: [erna.sari@kwikkianjie.ac.id](mailto:erna.sari@kwikkianjie.ac.id) Orcid: <https://orcid.org/0009-0002-4300-8806>

**Estrutura teórica:** Este estudo baseia-se na relação entre infraestrutura de tecnologia, empréstimos digitais e pagamentos digitais e seu impacto nos resultados econômicos e sociais. O estudo baseia-se em teorias de adoção e difusão de tecnologia, inclusão financeira e desenvolvimento humano.

**Desenho/metodologia/abordagem:** Este estudo usou pesquisa quantitativa para examinar como a infraestrutura de tecnologia, empréstimos digitais e pagamentos digitais afetam a renda, a saúde e a educação. A amostra consistia em dados de 2015-2020, limpos e analisados usando análise de regressão em E-views.

**Resultados:** Os resultados revelaram que a infraestrutura tecnológica tem um efeito positivo significativo na renda real per capita e na saúde pública, mas um efeito negativo e insignificante no nível de educação. O empréstimo digital foi insignificamente positivo para a renda real per capita e negativamente insignificante para os níveis de saúde pública e educação. Em contraste, os pagamentos digitais tiveram um impacto positivo e significativo nos níveis de saúde e educação, mas um efeito negativo e insignificante na renda real per capita.

**Pesquisa, implicações práticas e sociais:** O estudo sugere que os governos devem priorizar o desenvolvimento de infraestrutura de tecnologia da informação para as PMEs para aumentar a renda per capita real e a saúde pública. Além disso, as leis e regulamentações relevantes devem ser aprimoradas para garantir o desenvolvimento de pagamentos digitais, sistemas de investigação de crédito e transações de pagamento digital padronizadas para manter a segurança financeira e estimular a demanda do consumidor, promovendo o desenvolvimento econômico sustentável.

**Originalidade/valor:** A originalidade deste estudo reside na investigação do impacto da infraestrutura tecnológica e das finanças digitais na renda, saúde e educação. Além disso, o estudo destaca a importância de abordar questões regulatórias para garantir o uso seguro e eficaz das finanças digitais.

**Palavras-chave:** Inovação Digital, Crescimento Econômico, Infraestrutura de Tecnologia, Segurança Financeira, Desenvolvimento Econômico Sustentável.

## EL IMPACTO DE LA INNOVACIÓN DIGITAL EN EL CRECIMIENTO ECONÓMICO

### RESUMEN

**Propósito:** Este estudio tuvo como objetivo examinar el impacto de la infraestructura tecnológica, los préstamos digitales y los pagos digitales en el ingreso real per cápita, la salud pública y los niveles de educación.

**Marco teórico:** Este estudio se basa en la relación entre la infraestructura tecnológica, los préstamos digitales y los pagos digitales y su impacto en los resultados económicos y sociales. El estudio se basa en teorías de adopción y difusión de tecnología, inclusión financiera y desarrollo humano.

**Metodología:** Este estudio utilizó investigación cuantitativa para examinar cómo la infraestructura tecnológica, los préstamos digitales y los pagos digitales afectan los ingresos, la salud y la educación. La muestra fueron datos de 2015-2020, limpiados y analizados mediante análisis de regresión en E-views.

**Conclusiones:** Los hallazgos revelaron que la infraestructura tecnológica tiene un efecto positivo significativo sobre el ingreso real per cápita y la salud pública, pero un efecto negativo e insignificante sobre el nivel educativo. Los préstamos digitales fueron insignificamente positivos para el ingreso real per cápita y negativamente insignificantes para los niveles de educación y salud pública. En contraste, los pagos digitales tuvieron un impacto positivo y significativo en los niveles de salud y educación, pero un efecto negativo e insignificante en el ingreso real per cápita.

**Implicaciones de la Investigación:** El estudio sugiere que los gobiernos deberían priorizar el desarrollo de infraestructura de tecnología de la información para las PYME a fin de aumentar el ingreso real per cápita y la salud pública. Además, se deben mejorar las leyes y regulaciones pertinentes para garantizar el desarrollo de pagos digitales, sistemas de investigación de crédito y transacciones de pago digital estandarizadas para mantener la seguridad financiera y estimular la demanda de los consumidores, lo que en última instancia promueve el desarrollo económico sostenible.

**Originalidad/valor:** La originalidad de este estudio radica en su investigación del impacto tanto de la infraestructura tecnológica como de las finanzas digitales en los ingresos, la salud y la educación. Además, el estudio destaca la importancia de abordar los problemas regulatorios para garantizar el uso seguro y eficaz de las finanzas digitales.

**Palabras clave:** Innovación Digital, Crecimiento Económico, Infraestructura de Tecnología, Seguridad Financiera, Desarrollo Económico Sostenible.

## INTRODUCTION

The rise of digital innovation has significantly impacted the way businesses operate, particularly in the realm of SMEs. Digital technology has enabled SMEs to access new markets, improve their operational efficiency, and develop innovative products and services. As a result, SMEs have become important drivers of economic growth and job creation in many countries.

However, despite the potential benefits of digital innovation for SMEs, there are also challenges associated with implementing and managing digital technologies. These challenges include issues related to digital infrastructure, cybersecurity, and workforce training. Thus, it is important for SMEs to have a clear understanding of the opportunities and risks associated with digital innovation in order to make informed decisions about how to invest in this area.

One key aspect of digital innovation is the emergence of digital ecosystems, which are networks of interconnected actors (e.g. firms, customers, regulators) that collaborate to create value through digital platforms and technologies. These ecosystems have the potential to drive innovation, improve efficiency, and create new opportunities for SMEs, but they also present new challenges related to competition, data privacy, and regulatory compliance.

In today's business world, small and medium enterprises (SMEs) face intense competition that emphasizes stability and continuous improvement. The ability of SMEs to manage their resources sustainably and develop their organizations optimally leads to innovation in products, services, and processes, which in turn results in higher performance. The Resource-Based View (RBV) and Market-Based View (MBV) theories are commonly used in the literature on sustainable SME activities to gain competitive advantage.

Sustainable SMEs are concerned with creating wealth and developing opportunities by exploring market externalities and efficiencies and assessing the potential social impact of resulting innovations. However, understanding the role of agents and users in the digital economy requires a system model that is easy to use and accepted by SMEs. Digitalization is not just a technology; it is also about the digital ecosystem, and entrepreneurship has ecosystem literature as well. Therefore, the two are integrated to form a new concept known as the digital entrepreneurship ecosystem.

Digital economy entrepreneurship is focused on creating digital companies and innovative products and services for many users and agents in the global economy. The Technology Acceptance Model (TAM) and Theory of Reasoned Action (TRA) are commonly used theories in this field.

Digital innovation is an important aspect for small and medium-sized enterprises (SMEs) to increase innovation, introduce new products and processes, and create competitiveness and innovation (Muñoz et al., 2022). The importance of digitalization impacts the creation of new opportunities for SMEs such as the Internet of things (IoT), artificial intelligence (AI), machine learning (ML), 3D printing, robotics, and blockchain (Pinchot & Soltanifar, 2021). This opens up new possibilities for developing improved products, logistics and business processes as well as providing tools to measure the quality of ownership history of social and environmental attributes of the supply chain. This is important because it affects the capacity of organizations to manage supply chains and sustainable SMEs.

Digital SMEs are any SMEs that use digital means as an important component of their innovation initiatives. The most important form of digital innovation for companies in traditional industries including SMEs is not about new digital products or services, but rather about more effective and efficient ways to market, communicate with customers, operational processes and using exponential technology. Digital SMEs offer innovation opportunities that can create major transformations in efficiency with customer communications, collaborate with suppliers, make more data-driven decisions, automate diagnostics, manage natural resources such as energy or water, and optimize logistics and process control with modest investments.

It was concluded that digital SMEs are SMEs that use the entrepreneurial spirit to obtain profits and simultaneously to give meaning to work in implementing ideas to produce digital innovations. Digital innovation in this study was measured through: a) Technology infrastructure analyzes the creation of technology-based SMEs that contribute to job creation and updating the economic system (Muñoz et al., 2022); b) Digital lending access to obtain financing using digital (Björkegren & Grissen, 2018); and c) Digital payment is a transaction of business results using digital (Almeida et. al 2021).

Meanwhile, economic growth is the achievement of sustainable per capita income growth. The output produced must be faster than the growth of its population. Gross national income level per capita is used to measure economic well-being. Changes in the structure of production and employment are developmental strategies that focus on rapid industrialization (Todaro & Smith, 2014). Economic growth in this study will be measured through three aspects of development, namely: a) Real income per capita adjusted for purchasing power; b) Health as measured by life expectancy, malnutrition, and child mortality; and c) Educational attainment as measured by literacy and schooling

The research gap of this research is the integration of SMEs with digital to increase economic growth. A research by Che & Zhang (2019) entitled Contextual determinants of e-entrepreneurship: Opportunities and challenges examines the impact of contextual factors on e-entrepreneurship opportunities with exploratory case study methods. The finding is the existence of a social phenomenon where SMEs are faced with direct or indirect pressure to use technology to be sustainable. Furthermore, research by Tur-Porcar et al. (2018) entitled Factors Affecting Entrepreneurship and Business Sustainability using AHP research tools and carried out in Spain advises that the sustainability of SMEs should consider the growth of corporate value and economic growth as well as environmental integrity and social sustainability. Sustainable SMEs occur in a competitive environment, resulting in profits that support sustainable SMEs. The limitation of this study is that this method is based on expert criteria, giving rise to different interpretations. Research by Matejun (2016) used a survey on managers of 30 SMEs, and the results of the study found that SMEs surveyed believe that the technology used by SMEs can increase interaction with consumers and involvement in the scope of technology. This highlights the importance of digital innovation in enhancing SMEs' interaction with customers and expanding their reach in the market. Another study by Ebong & Babu (2020) sought to ascertain the factors driving SME credit demand and draw implications for innovation and adoption of digital lending. The research approach used qualitative and quantitative methods, and the results showed that the support of digital loans can increase business development through SME innovation. This further emphasizes the potential of digital innovation to drive economic growth through SMEs.

In sum, digital innovation has become increasingly crucial for SMEs to enhance their competitiveness, productivity, and sustainability. The integration of digital means, such as IoT, AI, ML, 3D printing, robotics, and blockchain, offers new opportunities for developing improved products, logistics, and business processes, as well as providing tools to measure the quality of social and environmental attributes of the supply chain (Piranda et al., 2022). By leveraging digital innovation, SMEs can create major transformations in efficiency, customer communications, collaboration with suppliers, data-driven decision-making, natural resource management, and process control with modest investments. Through studies like Matejun (2016) and Ebong and Babu (2020), it is evident that digital innovation has a significant impact on SMEs, driving economic growth and creating sustainable business models (Puriwat et.al 2021).

Based on the issue above, this study aims to explore the role of the digital entrepreneurship ecosystem in driving innovation and competitiveness among sustainable SMEs. Specifically, this study will investigate the factors that influence the adoption and use of digital technologies and platforms within the ecosystem, as well as the impact of these technologies on firm performance and social and environmental outcomes. By examining these issues, this study aims to contribute to a deeper understanding of the opportunities and challenges associated with digital innovation for sustainable SMEs, and to provide insights that can help policymakers and practitioners to better support the development of these firms. Given the importance of SMEs as drivers of economic growth and job creation, and the increasing importance of digital technologies in today's economy, this study has significant implications for the sustainable development of SMEs and the broader economy.

## METHODOLOGY

This study used a quantitative research approach to examine the impact of technology infrastructure, digital lending, and digital payments on real per capita income, public health, and education levels. The sample used in this study was the secondary data from 2015 to 2020, which was obtained from reliable sources. The data collected were then cleaned, filtered, and transformed to be ready for analysis.

To analyze the data, the study used regression analysis with e-views. Regression analysis was chosen as the appropriate statistical technique to determine the strength and direction of the relationship between the variables under investigation.

Finally, limitations of the study included the fact that it used secondary data from existing sources, which may not have included all the necessary variables. Additionally, the study's findings may not be generalizable to other populations beyond the scope of the study.

Figure 1: Research Models and Hypotheses

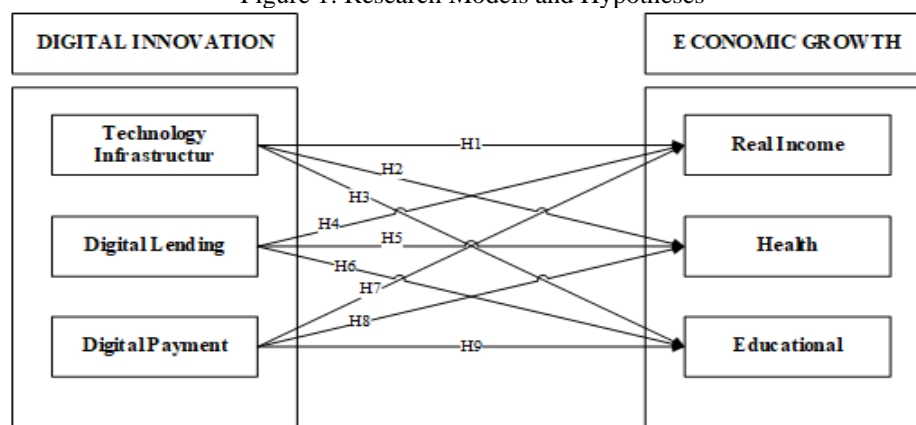



## RESULT AND DISCUSSION

Based on Table 1, Hypothesis 1 is supported, indicating that technological infrastructure has a significant positive effect on real income per capita. This result is consistent with previous research (Toader et al., 2018), which demonstrated the positive and strong influence of information technology infrastructure on real income per capita in EU countries.

Moreover, our study also supports Hypothesis 2, revealing that technological infrastructure has a significant positive effect on the level of public health. Specifically, the increasing improvement of SME technology infrastructure has a positive impact on public health by enhancing the accessibility of information and products to improve health, facilitating the mobility of goods and population, and reducing the cost of shipping goods. This finding aligns with the research of Wicks-Lim & Arno (2017), who demonstrated that an increase in per capita income is associated with improved population health.

However, our study did not find a significant relationship between technological infrastructure and education levels, as suggested by Hypothesis 3. It is important to note that our study only focused on SMEs and did not consider larger firms, which may have a different level of technological infrastructure. Additionally, our study only focused on one country, which may limit the generalizability of the results to other contexts.

Table 1: Test Results of the Effect of Technology Infrastructure on Real Income Percapita, Public Health Level and Education Level

Dependent Variable: Y1 Method: Least Squares Date: 01/16/23 Time: 17:50 Sample: 2015 2020 Included observations: 6				
Variable	Coefficient	Std. Error	t-Statistic	Prob.
C	652.1741	283.6347	2.299345	0.1482
X1	7.7800 07	7.6900 05	4.028939	0.0495
X2	5.005845	0.002777	2.104693	0.0170
X3	-0.101307	0.188451	-0.537579	0.6447
R-squared	0.955787	Mean dependent var		1009.728
Adjusted R-squared	0.889467	S.D. dependent var		84.44526
S.E. of regression	28.07514	Akaike info criterion		9.742367
Sum squared resid	1576.427	Schwarz criterion		9.603540
Log likelihood	-25.22710	Hannan-Quinn criter.		9.186631
F-statistic	1 6.41174	Durbin-Watson stat		2.283980
Prob(F-statistic)	0.045581			

Based on the results presented in Table 2, our study found that Hypothesis 4, which posits that positive digital lending has a significant effect on real income per capita, was not

supported. This finding aligns with the research conducted by Cumming & Hornuf (2022), which suggests that entrepreneurs who are less experienced in managing their businesses and less profitable SMEs are more reliant on external financing, making positive digital lending less significant for economic outcomes.

Additionally, our study did not find significant relationships between negative digital lending and either public health or education levels, supporting Hypotheses 5 and 6. Again, this result is in line with the findings of Cumming & Hornuf (2022), who argue that SMEs with weaker financial positions are more likely to experience negative digital lending, which may not have a significant impact on social outcomes.

Table 2: Test Results of the Effect of Digital Lending on Real Income Percapita, Public Health Level and Education Level

Dependent Variable: Y2  
Method: Least Squares  
Date: 01/16/23 Time: 17:51  
Sample: 2015 2020  
Included observations: 6

Variable	Coefficient	Std. Error	t-Statistic	Prob.
C	74.38541	192.6101	0.386197	0.7366
X1	5.2500 06	1.83E-05	0.287732	0.8006
X2	-0.000261	0.001886	-0.138588	0.9025
X3	-0.038158	0.127973	-0.298175	0.7937
R-squared	0.141595	Mean dependent var		37.36000
Adjusted R-squared	-1.146014	S.D. dependent var		13.01444
S.E. of regression	19.06521	Akaike info criterion		8.968329
Sum squared resid	726.9645	Schwarz criterion		8.829502
Log likelihood	-22.90499	Hannan-Quinn criter.		8.412593
F-statistic	0.109967	Durbin-Watson stat		2.915691
Prob(F-statistic)	0.946719			

Table 3: Test Results of the Effect of Digital Payment on Real Income Percapita, Public Health Level and Education Level

Dependent Variable: Y3  
Method: Least Squares  
Date: 01/16/23 Time: 17:52  
Sample: 2015 2020  
Included observations: 6

Variable	Coefficient	Std. Error	t-Statistic	Prob.
C	16.15345	9.926368	1.627327	0.2452
X1	-7.39E-07	9.41E-07	-0.784677	0.5148
X2	8.58E-05	9.72E-05	0.882810	0.4705
X3	0.003781	0.006595	0.573260	0.6243
R-squared	0.461495	Mean dependent var		23.55587
Adjusted R-squared	-0.346263	S.D. dependent var		0.846814
S.E. of regression	0.982546	Akaike info criterion		3.037382



Sum squared resid	1.930794	Schwarz criterion	2.898555
Log likelihood	-5.112147	Hannan-Quinn criter.	2.481646
F-statistic	0.571328	Durbin-Watson stat	1.856615
Prob(F-statistic)	0.686491		

---

---

The results presented in Table 3 indicate that Hypothesis 7, which posits that digital payments have a negative but insignificant effect on real income per capita, was supported by our study. However, Hypotheses 8 and 9, which suggest a positive effect of digital payments on health and education levels, were found to be supported by the data. These findings align with the research conducted by Zhou (2022), who argues that the use of electronic payments can significantly impact real income per capita by making transactions more convenient, efficient, and secure. Additionally, electronic payments can help individuals access consumer credit and financial resources more easily, enabling them to participate more actively in the digital economy.

While some studies have found no clear effect of electronic payments on consumption, our study suggests that there is a stable and causal long-term relationship between cash and bank cards, mobile payments, and consumption. Mao & Chen (2015) also found that mobile payments have significant substitution effects on traditional currencies and bank cards. However, vulnerable consumers may face barriers to the use of electronic payments, particularly in rural areas where there are few accounts capable of accepting electronic payments. Anderson et al. (2018) found that these households are often the slowest to adopt electronic payments.

Despite its valuable insights, this study is not without limitations. The chosen sample period, spanning from 2015 to 2020, might not capture the full extent of the influence of technology infrastructure, digital lending, and digital payments on public health and education levels. Additionally, the accuracy of the data used could be questionable as it was sourced from related agencies rather than the government. Future studies could tackle these limitations by utilizing authentic data and expanding the time frame.

## CONCLUSION AND SUGGESTION

In conclusion, the findings of this study suggest that technology infrastructure, digital lending, and digital payments have varying effects on real per capita income, public health, and education. It is clear that technology infrastructure plays a significant role in increasing real per capita income and improving public health, but has little effect on the level of education. Digital payments, on the other hand, have a significantly positive effect on both public health and

education, but have no significant impact on real per capita income. Digital lending was found to be insignificantly positive for real per capita income and negatively insignificant for public health and education level.

Suggestion To promote economic growth, it is crucial for governments to prioritize the development of technology infrastructure for SMEs to provide easy access to this technology. This can increase real per capita income, which can ultimately affect the level of public health. Furthermore, it is necessary to improve relevant laws and regulations to ensure the development of digital payments, build and improve credit investigation systems, standardize digital payment transactions, and accelerate financial technology innovation. By doing so, we can encourage the development of digital payments while maintaining financial security. Limitations, It is also important to give full play to the specific role of digital payments in stimulating consumer demand and promoting sustainable economic development.

## REFERENCES

- Anderson, D. M., Strand, A., & Collins, J. M. (2018). The impact of electronic payments for vulnerable consumers: Evidence from social security. *Journal of Consumer Affairs*, 52(1), 35–60. <https://doi.org/https://doi.org/10.1111/joca.12140>
- Björkegren, D., & Grissen, D. (2018). The potential of digital credit to bank the poor. *AEA Papers and Proceedings*, 108, 68–71. <https://doi.org/10.1257/pandp.20181032>
- Almeida, J. M. S. de, da Costa, P. R., Pires, A. de C., & Pigola, A. (2021). Relational Capability: A Prospective Study at Brazilian Technological-Base Enterprises in Biotech Industry. *International Journal of Professional Business Review*, 7(1), e0233. <https://doi.org/10.26668/businessreview/2022.v7i1.233>
- Che, Y., & Zhang, B. (2019). Contextual determinants of e-entrepreneurship: opportunities and challenges. *International Journal on Semantic Web and Information Systems (IJSWIS)*, 15(3), 1–15. <https://doi.org/10.4018/IJSWIS.201907011>
- Cumming, D., & Hornuf, L. (2022). Marketplace lending of small-and medium-sized enterprises. *Strategic Entrepreneurship Journal*, 16(1), 32–66. <https://doi.org/https://doi.org/10.1002/sej.1411>
- Ebong, J., & Babu, G. (2020). Demand for credit in high-density markets in Kampala: Application of digital lending and implication for product innovation. *Journal of International Studies*, 13(4), 295–313. <https://doi.org/https://doi.org/10.3390/su10103750>
- Mao, L., & Chen, S. (2015). The growth of mobile payment and effect on consumption via cash and bankcard. *2015 8th International Conference on Biomedical Engineering and Informatics (BMEI)*, 872–877. <https://doi.org/https://doi.org/10.1109/BMEI.2015.7401625>
- Matejun, M. (2016). Role of technology entrepreneurship in the development of innovativeness of small and medium-sized enterprises. *Management*, 20(1), 167–183.

<https://doi.org/https://doi.org/10.1515/manment-2015-0032>

Muñoz, C., Galvez, D., Enjolras, M., Camargo, M., & Alfaro, M. (2022). Relationship between innovation and exports in enterprises: A support tool for synergistic improvement plans. *Technological Forecasting and Social Change*, 177, 121489. <https://doi.org/https://doi.org/10.1016/j.techfore.2022.121489>

Pinchot, G., & Soltanifar, M. (2021). Digital intrapreneurship: The corporate solution to a rapid digitalisation. *Digital Entrepreneurship: Impact on Business and Society*, 233–262. [https://doi.org/https://doi.org/10.1007/978-3-030-53914-6\\_12](https://doi.org/https://doi.org/10.1007/978-3-030-53914-6_12)

Piranda, D. R., Sinaga, D. Z., & Putri, E. E. (2022). Online Marketing Strategy In Facebook Marketplace As A Digital Marketing Tool. *Journal of Humanities, Social Sciences and Business (JHSSB)*, 1(3), 1–8. <https://doi.org/https://doi.org/10.55047/jhssb.v1i2.123>

Puriwat, W. ., & Tripopsakul, S. . (2021). Understanding Digital Social Responsibility in the Social Media Context: Evidence from Thailand . *International Journal of Professional Business Review*, 7(1), e0257. <https://doi.org/10.26668/businessreview/2022.v7i1.257>

Toader, E., Firtescu, B. N., Roman, A., & Anton, S. G. (2018). Impact of information and communication technology infrastructure on economic growth: An empirical assessment for the EU countries. *Sustainability*, 10(10), 3750.

Todaro, M. P., & Smith, S. C. (2014). *Human Capital: Education and Health in Economic Development-in Economic Development*. (Tehran (ed.)).

Tur-Porcar, A., Roig-Tierno, N., & Llorca Mestre, A. (2018). Factors affecting entrepreneurship and business sustainability. *Sustainability*, 10(2), 452. <https://doi.org/https://doi.org/10.3390/su10020452>

Wicks-Lim, J., & Arno, P. S. (2017). Improving population health by reducing poverty: New York's earned income tax credit. *SSM-Population Health*, 3, 373–381. <https://doi.org/https://doi.org/10.1016/j.ssmph.2017.03.006>

Zhou, R. (2022). Sustainable Economic Development, Digital Payment, and Consumer Demand: Evidence from China. *International Journal of Environmental Research and Public Health*, 19(14), 8819. <https://doi.org/https://doi.org/10.3390/ijerph19148819>