

# Exergy Balance Applied to a Gas Turbine in a Modified Brayton Cycle to Assess the Power Output Recovery

## Balance de exergía de la Turbina de Gas en un Ciclo Brayton modificado para evaluar Recuperación de Potencia de Salida

DOI: <http://doi.org/10.17981/ingecuc.16.2.2020.04>

Scientific Research Article. Date Received: 16/12/2019. Acceptance Date: 24/04/2020.

**Daniel Forero-Florian** 

Universidad de los Andes. Bogotá, D.C. (Colombia)  
de.forero@uniandes.edu.co

Para citar este artículo:

D. Forero-Floria “Exergy Balance Applied to a Gas Turbine in a Modified Brayton Cycle to Assess the Power Output Recovery”, *INGE CUC*, vol. 16, no. 2, pp. 45–66, 2020. DOI: <http://doi.org/10.17981/ingecuc.16.2.2020.04>

### Abstract

**Introduction**— Gas turbines play a key role in the power generation industry. The UPME (Unidad de Planeación Minero-Energética), in its monthly report of the generation variables and the Colombian electricity market, quoted data from December 2016, highlights that the net effective capacity in megawatts is 2,093 and represents about 12.61% of the total energy capacity through gas thermal plants. During hot seasons, the performance of the turbines is affected by the elevated air temperature flowing into the cycle, because the power output depends on the air mass flow through the compressor, the mass flow decreases as the temperature increases, resulting in a decline in efficiency and power generation.

**Objetivo**— A gas turbine in open cycle was analyzed based on the first and second law of thermodynamics, irreversibilities were considered using exergy as the criterion to establish the overall performance of the system.

**Methodology**— An alternative analysis was proposed modifying the ideal Brayton cycle, humidity of the air, the height above sea level, and the detailed molar composition by component were considered. Furthermore, the heat adding process was replaced by an adiabatic and isobaric combustion progression with a subsequent cooling by means of an adiabatic mixture of ideal gases with the compressor discharged air to condition the incoming flow mixture of gases to the turbine aimed to maintain the maximum allowed temperature controlled.

**Results**— The simulation was developed in the software EES (Engineering Equation Solver) and the free software CEA (Chemical Equilibrium with Applications) from NASA was used to validate results for the combustion process, under the criterion of chemical equilibrium. Few investigations about inlet cooling methods for gas turbines have supported the implementation of such kind of technologies by means of exergy balance, which is the main goal of this research.

**Keywords**— Gas turbine; exergy balance; irreversibility; turbine inlet coolin

### Resumen

**Introducción**— Las turbinas de gas juegan un papel fundamental en la industria de generación eléctrica. La UPME (Unidad de Planeación Minero-Energética), en su informe mensual de las variables de generación y del mercado eléctrico colombiano, citando datos de diciembre de 2016, destaca que la capacidad efectiva neta en megavatios es de 2.093 y representa cerca del 12.61% de la capacidad total de energía a través de plantas térmicas de gas. Durante las estaciones cálidas, el rendimiento de las turbinas se ve afectado por la elevada temperatura del aire que fluye en el ciclo, ya que la potencia depende del flujo de masa de aire que pasa por el compresor, el flujo de masa disminuye a medida que aumenta la temperatura, lo que resulta en una disminución de la eficiencia y la generación de energía.

**Objetivo**— Se analizó una turbina de gas en ciclo abierto, basándose en la primera y segunda ley de la termodinámica, se consideraron las irreversibilidades utilizando la exergía como criterio para establecer el rendimiento global del sistema.

**Metodología**— Se propuso un análisis alternativo modificando el ciclo Brayton ideal, se consideró la humedad del aire, la altura sobre el nivel del mar y la composición molar detallada por componente. Además, se sustituyó el proceso de adición de calor por una progresión de combustión adiabática e isobárica con un posterior enfriamiento mediante una mezcla adiabática de gases ideales con el aire de descarga del compresor para acondicionar la mezcla de flujo de gases de entrada a la turbina con el objetivo de mantener controlada la temperatura máxima permitida.

**Resultados**— La simulación se desarrolló en el software EES (Engineering Equation Solver) y se utilizó el software gratuito CEA (Chemical Equilibrium with Applications) de la NASA para validar los resultados del proceso de combustión, bajo el criterio de equilibrio químico.

**Conclusiones**— Pocas investigaciones sobre métodos de refrigeración de entrada para turbinas de gas han apoyado la implementación de este tipo de tecnologías mediante el balance de exergía, que es el objetivo principal de esta investigación.

**Palabras clave**— Turbina de gas; balance de exergía; irreversibilidad; enfriamiento de la entrada de la turbina

## I. INTRODUCTION

Gas turbines have been used for electricity production and mechanical drive applications in many regions around the world, widely applied in airplanes, refineries, and various industrial services. The focus of this analysis was aimed for power generation in an open cycle internal combustion engine, single shaft model. The volumetric air flow into the engine is constant, hence specific volume of the incoming air is directly proportional to temperature. The augmentation of this specific fluid property will rise compressor work on the system, thus reducing net power output. Power output is directly proportional to the mass flow of air through the system. Decreasing air specific volume of the incoming air, thereof, increasing air density play a key role in the power produced by the engine. The scope of this research involves the study of a simple cycle gas turbine to explain the inlet temperature influence in the exergy expended, degraded and recovered on the entire system and clearly visualize the power output, efficiency, heat rate, inlet air mass flow rate and exhaust gases temperature performance. The exergy destruction, complement widely the justification for the implementation of air cooling methods to recover the power output in hot weather conditions. Hardly any types of researches regarding cooling air methods refers to exergy on their analyses, but some researches have generally studied commercial inlet cooling methods to improve performance on power plants.

From studies of the influence of ambient air temperature on power output [1], it has been shown that when evaporative cooling the intake air was cooled and gas turbine power produced increased but final temperature was constrained by the air wet bulb or relative humidity. On the other hand, using absorption chiller technology, final air temperature is not constrained by weather conditions. Other studies showed that gas turbine thermal efficiency is affected by ambient temperature, increasing as ambient temperature remains low, so, power plant specific fuel consumption surge with increase in ambient temperature [2]. Furthermore, it has been found that the effect of ambient temperature on the exergy efficiency of the components of a gas turbine, all the components described a reduction in efficiency as ambient air temperature increases [3]. At several temperatures the rate of irreversibility, exergy productivity and the imperfections were highlighted for each component and the entire plant, where the combustion chamber and the turbine were the higher destruction exergy devices. On the other hand, the fundamental concepts of exergy theory have been examined, studying the performance of engineering devices in the light of the second law of thermodynamics [4]. Reversible work, irreversibilities, second law efficiency and exergy balances to control volumes have been widely developed by them. By performing an exergy balance in a gas turbine power plant and analyzing the influence of several factors such as compressor ratio, compressor inlet temperature and turbine inlet temperature, it has been revealed that the most sensitive component in terms of irreversibilities for a gas turbine was the combustor [5]. The negative effect on turbine power due to the increase in ambient temperature with respect to the design point, called ISO conditions, can be described, which clearly indicated the advantages of cooling the inlet air to the compressor, especially in hot climates [6].

First section describes the mathematical approach based on thermodynamic principles that govern a modified simple and open cycle gas turbine model. The design conditions for the reference performance are defined, also the assumptions that delimit and simplify the problem. Mass, energy and exergy balance equations are proposed for each device: Compressor, combustion chamber and turbine. Additionally, an exergy analysis to the surroundings in regards to the flue gases release to the atmosphere must be included to define the overall performance of the system.

Coupled with the analytical approach, second part shows the results of the simulation carried out with the Engineering Equation Solver (EES) software, in which the set of equations proposed has been left as a function of the inlet temperature, a variation in a defined range allows to elucidate the power output reduction impact, efficiency and increase of the irreversibilities of the components, at elevated temperatures. The simulation validation for the analysis of the adiabatic combustion and the molar composition of the products was carried out with the free software Chemical Equilibrium with Applications (CEA) of NASA. Equally important, the third part summaries destroyed and recovered exergy plus second law efficiency for the whole system.

## II. METHODS-GAS TURBINE THERMODYNAMIC MODELLING

The proposed gas turbine is an open cycle single shaft design, Fig. 1 depicts the schema with the basic components considered for this study. Compressor C, Combustion Chamber C.C and Turbine T. The selected fuel is methane. The cycle was evaluated at ISO standard conditions, ISO 3977-3 Second edition, 2004, and . This is the standard reference point, from which operation parameters deviations are going to be compared to.

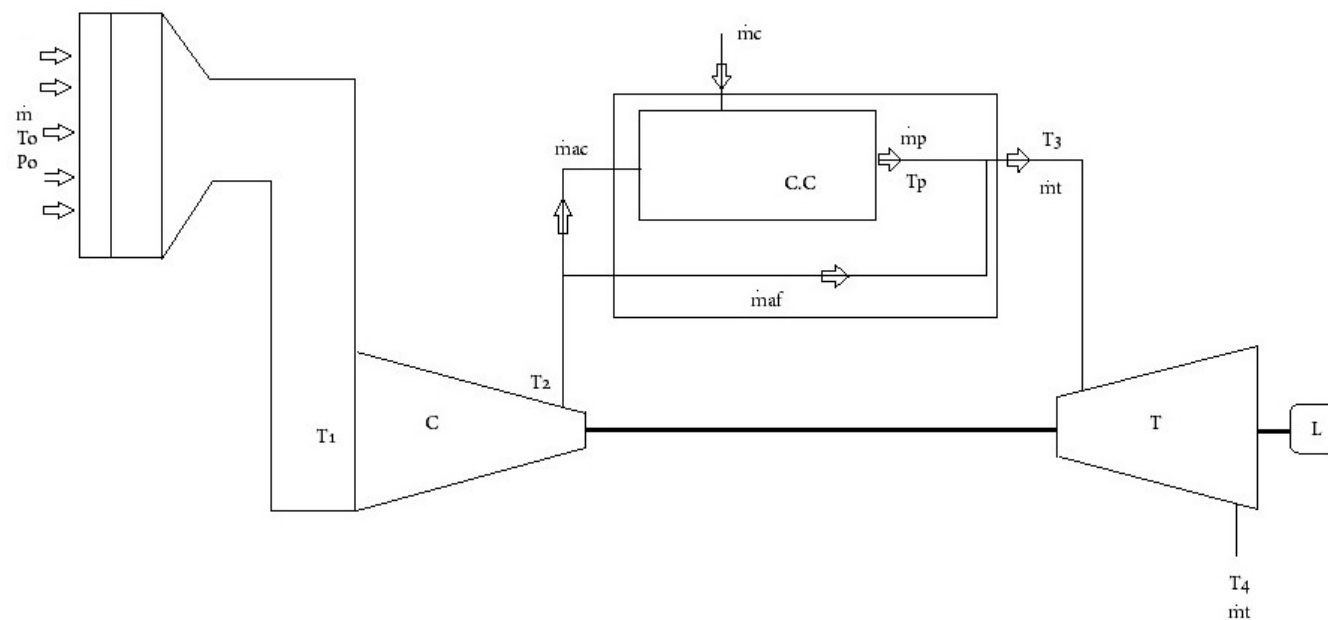

Fig. 1. Simple Cycle Gas Turbine Illustration.  
Source: Authors.

*Assumptions:* The gas turbine model was developed under the following assumptions: (i) Ideal gas mixture principles apply for wet air inflowing the compressor, combustion products as well as for fuel entering the combustion chamber, (ii) steady flow, (iii) all components are adiabatic, (iv) isobaric combustion process takes place, moreover cooling air from the compressor cool the combustion products off, which controls turbine inlet temperature (v), turbine inlet temperature is a safety control operation limit, so it is a known parameter (vi) isentropic compressor and turbine efficiencies are defined, (vii) compressor and turbine pressure ratio are established, (viii) negligible potential and kinetic energies assumption, (ix) combustion process is near stoichiometric [7]. Ten percent air excess was considered (AC: combustion air and fuel gas ratio is defined), with  $N_2$ ,  $CO_2$ ,  $H_2O$ ,  $CO$ ,  $NO_2$ ,  $NO$  and  $O_2$  as main combustion products. (x) Pressure drops are negligible, (xi) exhaust gas products after expansion are released to the atmosphere, and this means there is not a heat recovery steam generator. Mass, energy and exergy balances were assessed for each component using the thermodynamic performance criteria. Compressor inlet temperature was varied over a range of thirty Celsius,  $10^\circ C$ - $40^\circ C$ , to visualize the impacts on: incoming air mass flow rate, compressor and turbine performance, overall efficiency, power output and heat rate were foremost targets based on first law of thermodynamics, while exergy destroyed-irreversibilities, second law efficiencies on compressor, combustion chamber, turbine, overall efficiency and recovered exergy.

Were clearly assessed by second law of thermodynamics criteria. The destroyed and recovered exergy ratio defines the second law efficiency concept. A key target is to justify or no the implementation of a turbine inlet cooling system to recover power and improve efficiency of the overall system using the exergy and energy criteria.

### A. Mass, Energy and Exergy governing equations

#### 1) Compressor

Wet air is compressed from weather conditions, in usual operation, steady state, without considering any compressor inlet air cooling method, the Fig. 2 shows the filter house, transition duct to the compressor and target states.

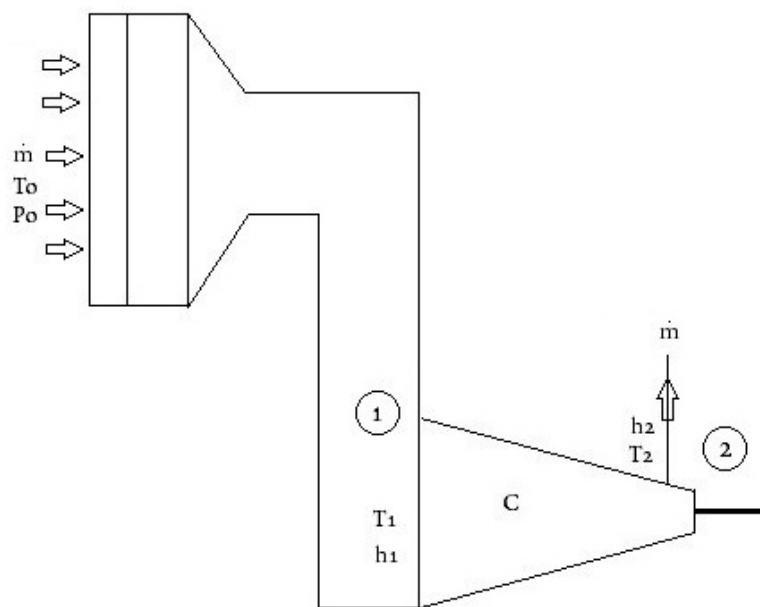

Fig. 2. Compressor, estates 1 & 2.  
Source: Authors.

Product of the energy balance in a stationary flow, adiabatic and work consumer device [8]. Can be defined the isentropic compressor efficiency  $\eta_c$ , this is a measure of the current deviation of a process with respect to the idealized, which implies a greater work demand by the compressor. The final discharge temperature can be determined fittingly as a function of the pressure ratio  $r_p$ , isentropic coefficient  $k$  and the isentropic efficiency  $\eta_c$ , [9] (1).

$$T_2 = \frac{T_1}{\eta_c} (r - 1 + \eta_c) \quad (1)$$

Following relation are also required (2):

$$r = r_p^{\frac{k-1}{k}}, r_p = \frac{P_2}{P_1}, k = \frac{C_p}{C_v}, C_p = \sum_i^n y_i C_{p_i}, C_v = C_p - R_u \quad (2)$$

Likewise, it is possible to calculate the current discharge temperature of the compressor directly from EES, so that we have the actual enthalpy [kJ/Kmol] of the actual process and with this property it is possible to determine the actual temperature  $T_{2a}$  [K] (3):

$$h_{2a}(T_{2a}) = \frac{h_{2s} - h_1}{\eta_c} + h_1 \quad (3)$$

The exergy amount flowing into a system, in stationary flow, occurs in the form of heat, work and mass, and must be equal to the amount of exergy output plus exergy destroyed [4] (4).

$$\sum \left(1 - \frac{T_o}{T_i}\right) \dot{Q}_i - \dot{W} + \sum \dot{N} \psi_{in} - \sum \dot{N} \psi_{out} - \dot{X}_{destroyed} = 0 \quad (4)$$

Where:

$\sum (1 - T_o/T_i) (\dot{q})$ : Exergy transfer by heat [kW].

$\sum \dot{N} \psi_{in} - \sum \dot{N} \psi_{out}$ : Exergy transfer by moles [kW].

For an adiabatic device which does not involve exergy flow by heat, it follows that (5):

$$\sum \dot{N} \psi_{in} - \sum \dot{N} \psi_{out} - \dot{W} - \dot{X}_{destroyed} = 0 \quad (5)$$

The corresponding change in the exergy flow, for an adiabatic device and single stream per unit mole is given by (6):

$$\psi_2 - \psi_1 = h_2 - h_1 - T_o (s_2 - s_1) \quad (6)$$

Here the reversible work is defined as the minimum power input for a consuming device, in other words, it is the exergy increment in the wet air compressed (7):

$$\dot{W}_{\text{revC}} = \dot{N}_m (\psi_2 - \psi_1) \quad (7)$$

And the actual work consumed by the compressor is (8):

$$\dot{W}_C = \dot{N}_m (h_2 - h_1) \quad (8)$$

Thus, second law efficiency is defined as (9):

$$\eta_{\text{IIc}} = \frac{\dot{W}_{\text{revC}}}{\dot{W}_C} \quad (9)$$

It is the ratio from the recovered and expended exergy.

## 2) Combustion Chamber

Former section was limited to a non-reacting thermodynamic process, conversely, combustion implies a chemical reacting progression. Combustion can be assumed stable, no external work involved, occurs at constant pressure and adiabatically [10]. Wet air  $\dot{m}_{ac}$  and methane  $\dot{m}_c$  are the reactants. After the combustion flue products  $\dot{m}_p$  are mixed with cooling air  $\dot{m}_{af}$  from the compressor at state 2, to fulfil turbine inlet temperature metallurgical restrictions. Fig. 3 describes the control volume.

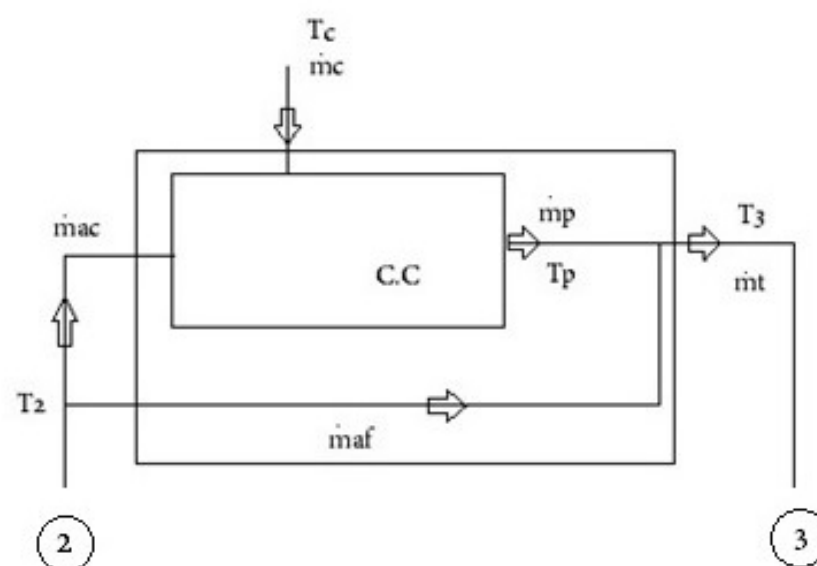
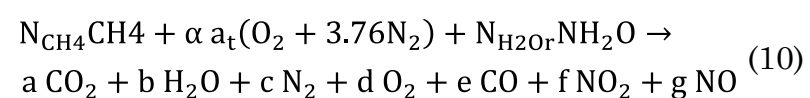

Fig. 3. Combustion chamber control volume.  
Source: Authors.

Due to main combustion products defined for this investigation were proposed to be  $N_2$ ,  $CO_2$ ,  $H_2O$ ,  $CO$ ,  $NO_2$ ,  $NO$  and  $O_2$ , to simplify the analysis, it is necessary to implement chemical equilibrium criteria for simultaneous reactions. A real approximation of the combustion process was based on the following reaction (10):



Thereof, the equilibrium composition of the reacting mixture needs to be determined, hence, we must relate the equilibrium constants  $k_p$  for each single reaction, with mass and energy balance that results in a system of simultaneous equations from which the composition can be

evaluated. The number of  $k_p$  relations needed is the difference between the number of species and the number of elements which results in three equilibrium constants, the following chemical reactions were taken in to consideration based on equation 10:

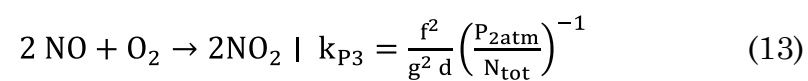
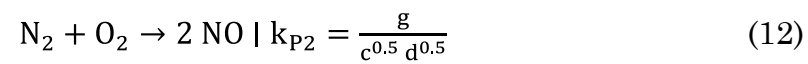
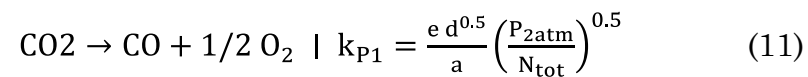

From energy balance for an adiabatic process enthalpy of products is equal to enthalpy of reactants (14):

$$\sum_i^{N_r} (N_{i_r} h_{i_r}(T_{i_r})) = \sum_j^{N_p} (N_{j_p} h_{j_p}(T_{prod})) \quad (14)$$

Now, we can determine products temperature,  $T_{prod}$ , which is the adiabatic flame temperature, thus, air is required to cool this flue gas to allowable turbine inlet temperature.

• *Combustion Chamber Energy balance*

During the combustion process some chemical bonds are broken, new ones are created, the chemical energy associated with these bonds is different for the products and the reactants, therefore, the chemical energy must be considered when carrying out the energy balance, EES allows to determine immediately the total enthalpy of each one of the constituents. Referring to Fig. 4, the control volume of the combustion chamber and mixing, it follows that:

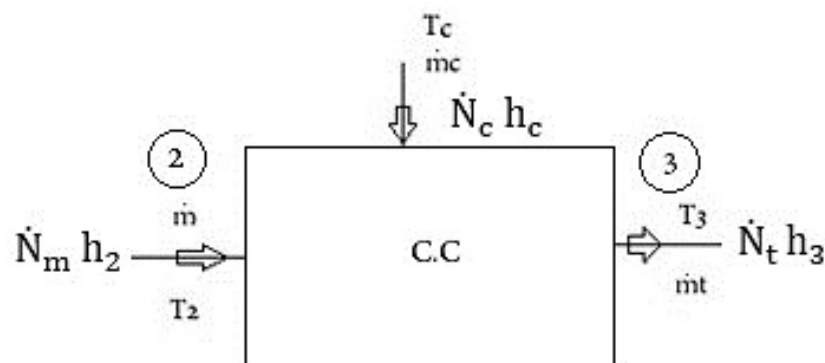

Fig. 4. Combustion chamber energy balance.  
Source: Authors.

$$\dot{N}_c h_c + \dot{N}_m h_2 = \dot{N}_t h_3 \quad (15)$$

Now we can estimate the mole fraction  $y_i$  of each constituent of the gas flue mixed with air incoming to the gas turbine, this is important to precisely evaluate the isentropic coefficient  $k_t$  for the expansion process that involves in determining final temperature of the process.

• *Combustion Chamber Exergy Balance*

The exergy balance in the combustion chamber is based on the destroyed exergy,  $X_{destroyed}$ , relation with the generated entropy,  $S_{gen}$ . Quoting the exergy destruction principle that is always a positive quantity and becomes zero for a reversible process, this represents the potential work loss or irreversibilities, defines as (16) [11]:

$$X_{destroyed} = T_o S_{gen} \geq 0 \quad (16)$$

Consequently, based in the idealized assumptions, generated entropy per kilomole of fuel is assessed firstly, see Fig. 5 and equations 17, 18 and 19.

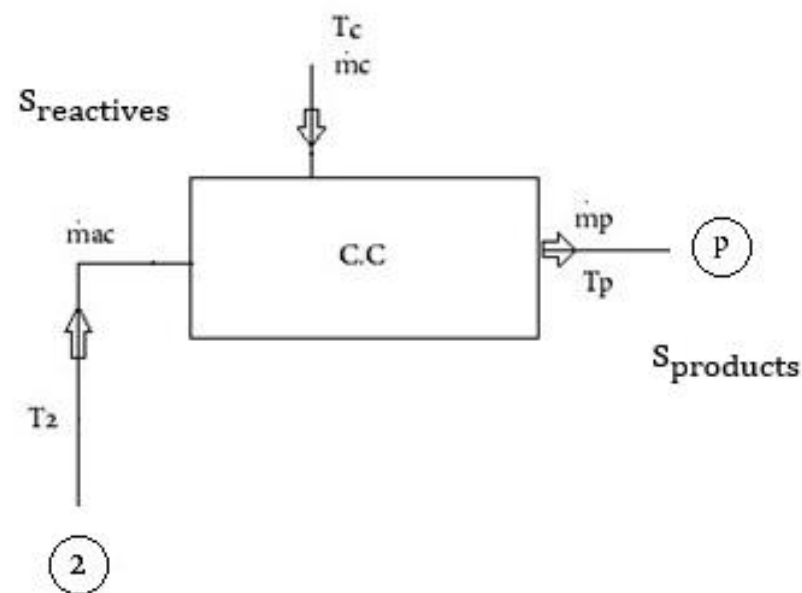

Fig. 5. Entropy balance adiabatic combustion.  
Source: Authors.

$$S_{\text{gen}} = S_{\text{products}} - S_{\text{reactives}} \geq 0 \quad (17)$$

$$S_{\text{reactives}} = \sum_i^{N_r} N_{i_r} s(T_{i_r}, P_{i_r}) / N_{\text{CH}_4} \quad (18)$$

$$S_{\text{products}} = \sum_i^{N_p} N_{i_p} s(T_{i_p}, P_{i_p}) / N_{\text{CH}_4} \quad (19)$$

Where  $P_{i_r/p}$  is the partial pressure of the constituent reactant or product  $i$  and  $T_{i_r/p}$  the respectively mixture temperatures. Former equations are based on the combustion reaction (10), which are evaluated per kilomole of fuel  $N_{\text{CH}_4}$  [kmol], so, once generated entropy is calculated, destroyed exergy associated to the chemical reaction must consider the actual fuel consumption  $\dot{N}_c$  [kmol/s], defined by (20):

$$\dot{X}_{\text{destroyed C.C.}} = T_o S_{\text{gen}} \dot{N}_c \quad (20)$$

is the generated entropy in the combustion process per kilomole of fuel. The maximum available work by the combustion chamber is related ideally with the Carnot heat engine, which operate in a reversible cycle, thermal efficiency is  $\eta_{\text{th}}$  (21):

$$\eta_{\text{th}} = \left(1 - \frac{T_2}{T_{\text{prod}}}\right) \quad (21)$$

The maximum work should consider the lower heating value, ergo, the hypothetical incoming heat to the cycle (22):

$$\dot{Q}_{\text{in}} = \text{LHV}_{\text{CH}_4} \dot{N}_c \quad (22)$$

This theoretical input heat should be related with the thermal efficiency, so the available work per unit time that a Carnot heat engine will produce will be  $\dot{W}_{\text{maxCC}}$  [kW] (23):

$$\dot{W}_{\text{maxCC}} = \eta_{\text{th}} \dot{Q}_{\text{in}} \quad (23)$$

Destroyed exergy in the combustion chamber lead to determine the real work that a heat engine could deliver working between the compressor temperature and the combustion products temperature, that means a power output  $\dot{W}_{CC}$ , this will be the difference between the maximum work of a heat engine operating between the inlet and outlet temperatures of the combustion chamber minus the destroyed exergy, combining equations 20 and 23 it follows that (24):

$$\dot{W}_{CC} = \dot{W}_{\max CC} - \dot{X}_{\text{destroyed C.C}} \quad (24)$$

The second law efficiency definition for the combustion chamber relates the recovered exergy with the available exergy, that is, the ratio of the recovered power and the maximum power available to do work,  $\eta_{II_{CC}}$  (25).

$$\eta_{II_{CC}} = \frac{\dot{W}_{CC}}{\dot{W}_{\max CC}} \quad (25)$$

The discharge cooling air of the compressor is then mixed with the products of combustion to reach the admissible temperature  $T_3$  [K] (Fig. 6).

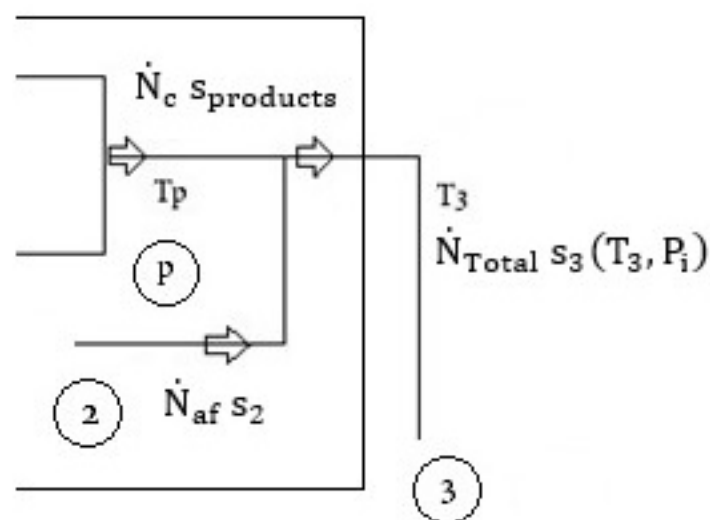

Fig. 6. Entropy balance in the mixing process.  
Source: Authors.

The generated entropy flow is described mathematically as (26)(27)(28):

$$\dot{S}_{\text{gen}} = \dot{S}_{\text{out}} - \dot{S}_{\text{in}} \geq 0 \quad (26)$$

$$\dot{S}_{\text{out}} = \dot{N}_{\text{Total}} s_3(T_3, P_i) \quad (27)$$

$$\dot{S}_{\text{in}} = \dot{N}_c s_{\text{products}} + \dot{N}_{af} s_2 \quad (28)$$

Where

$\dot{S}_{\text{out}}$ : Entropy flow of the total gas mixture [kmol/s · kJ/kmol K]

$\dot{S}_{\text{in}}$ : Entropy flow before mixing [kmol/s · kJ/kmol K]

Therefore, destroyed exergy in the mixing process is evaluated by (29):

$$\dot{X}_{\text{destroyed Mixing}} = T_o \dot{S}_{\text{gen}} \quad (29)$$

Total destroyed exergy in the combustion chamber must be (30):

$$\dot{X}_{\text{destroyed Total C.C}} = \dot{X}_{\text{destroyed C.C}} + \dot{X}_{\text{destroyed Mixing}} \quad (30)$$



### 3) Turbine

Flue gases at the adiabatic temperature  $T_{\text{prod}}$  are cooled by discharge air from the compressor at a lower temperature  $T_2$ , which creates a mixture of gases at controlled temperature  $T_3$ , this total mass flow, a mixture of gases enter the turbine, due to its high energy availability  $h_3(T_3)$  it is possible to

Extract useful mechanical work for electricity generation l: load (Fig. 7).

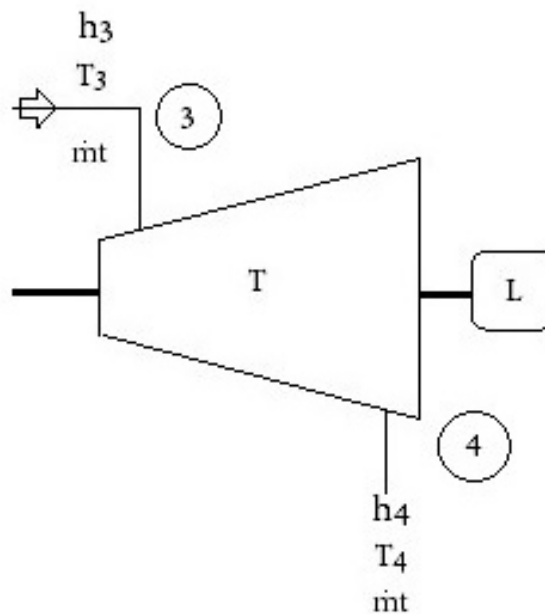

Fig. 7. Expansion gas turbine.  
Source: Authors.

As mentioned on compression progression, turbine final temperatures can successfully estimate as function of pressure ratio  $r_{pt}$ , isentropic coefficient  $k_t$ , and isentropic efficiency  $\eta_t$  (31) (32):

$$T_4 = T_3 \left( 1 - \eta_t \left( 1 - \frac{1}{r_t} \right) \right) \quad (31)$$

$$r_t = r_p^{\frac{k_t-1}{k_t}} \quad (32)$$

Also, it is possible to calculate the current discharge temperature of the turbine based on the enthalpy, so the actual temperature  $T_{4ag}$  [K] is defined by it (33):

$$h_{4ag}(T_{4ag}) = h_3 - \eta_t(h_3 - h_{4s}) \quad (33)$$

The exergy balance is assessed from the corresponding change in the exergy flow in the turbine per unit mole, given by (34):

$$\psi_3 - \psi_4 = h_3 - h_4 - T_0(s_3 - s_4) \quad (34)$$

Here, the reversible work per unit of time is defined as the maximum output of power for a work producing device, so reversible power in the turbine is defined by (35):

$$\dot{W}_{\text{revT}} = \dot{N}_{\text{Total}} (\psi_3 - \psi_4) \quad (35)$$

On the other hand, the actual work produced by the turbine is (36):

$$\dot{W}_T = \dot{N}_{\text{Total}} (h_3 - h_4) \quad (36)$$

Hence, second law efficiency is demarcated as (37):

$$\eta_{II} = \frac{\dot{W}_T}{\dot{W}_{revT}} \quad (37)$$

The net power output for the power plant is measured as the difference between the gas turbine actual power and the actual power consumed by the compressor (38):

$$\dot{W}_{Net} = \dot{W}_T - \dot{W}_C \quad (38)$$

The specific fuel consumption is a direct function of the fuel molar flow and inversely proportional to the net power output, defined as (39) [8]:

$$SFC = \frac{3600 \dot{N}_c}{\dot{W}_{Net}} \quad (39)$$

And the heat rate considers the lower heating value (40):

$$HR = SFC \text{ LHV} \quad (40)$$

This parameter is a power plant's efficiency measure, it relates the energy input in the system with the electrical energy generated. The first law of thermal efficiency is (41):

$$\eta_I = \frac{3600}{SFC \text{ LHV}} \quad (41)$$

#### 4) Destroyed exergy by the natural cooling process of the exhaust gases

Since the analysed system operates in open cycle, the exhaust gases are not being exploited to generate, for instance, steam, and building a combined cycle to increase the plant efficiency. Exhaust flue gases have an exergy that is degraded or destroyed because of natural cooling to weather temperature. Referring to Fig. 8,

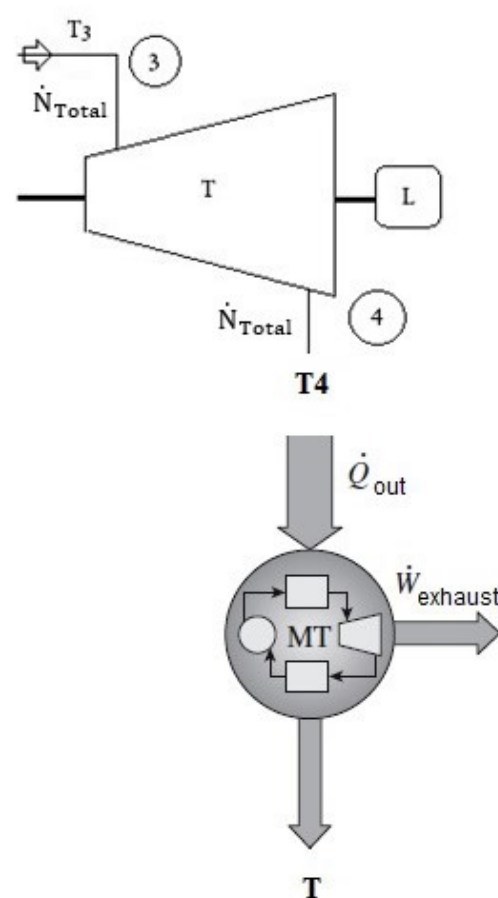

Fig. 8. Exhaust gases useful work.  
Source: Authors.

It is observed that a thermal machine could operate between the temperature  $T_4$  and the ambient temperature  $T$ , which implies that an available work is being wasted and must be considered in the exergy analyses of the overall system.

The heat rejected to the atmosphere  $\dot{Q}_{out}$  [kW] is evaluated from the first law of thermodynamics by (42):

$$\dot{Q}_{out} = \dot{N}_{Total} (h_4 - h_{oT}) \quad (42)$$

$h_{oT}$  enthalpy of the gases mixture at the end of the natural cooling process.

The reversible useful power that would deliver a Carnot heat engine is defined by  $\dot{W}_{exhaust}$  [kW]: (43).

$$\dot{W}_{exhaust} = \left(1 - \frac{T}{T_4}\right) \dot{Q}_{out} \quad (43)$$

The generated entropy during the heat rejection process to the atmosphere is analysed considering an extended system, which should include the exhaust gases and the immediate surroundings, that is the sum of the gas turbine exhaust gases entropy change and the entropy change of the atmospheric air around the chimney of the turbine (44):

$$\dot{S}_{genExhaust} = \dot{N}_{Total} (s_{oT} - s_4) + \frac{\dot{Q}_{out}}{T} \quad (44)$$

$\dot{N}_{Total} (s_{oT} - s_4)$  is the entropy change of flue gases or  $\Delta S_{Flue Gas}$ .

$\dot{Q}_{out}/T$  is the entropy change of the surroundings or  $\Delta S_{sur}$ .

Finally, destroyed exergy for the flue gases is (45):

$$\dot{X}_{destroyedExhaust} = \dot{S}_{genExhaust} T \quad (45)$$

##### 5) Total destroyed, recovered exergy and second law efficiency of the entire system

The total destroyed exergy of the entire system must be the sum of the destroyed exergy for each device and process. The recovered exergy must be the net power obtained that will be delivered to the load or electrical generator. Fig. 9 helps to elucidate this concept:

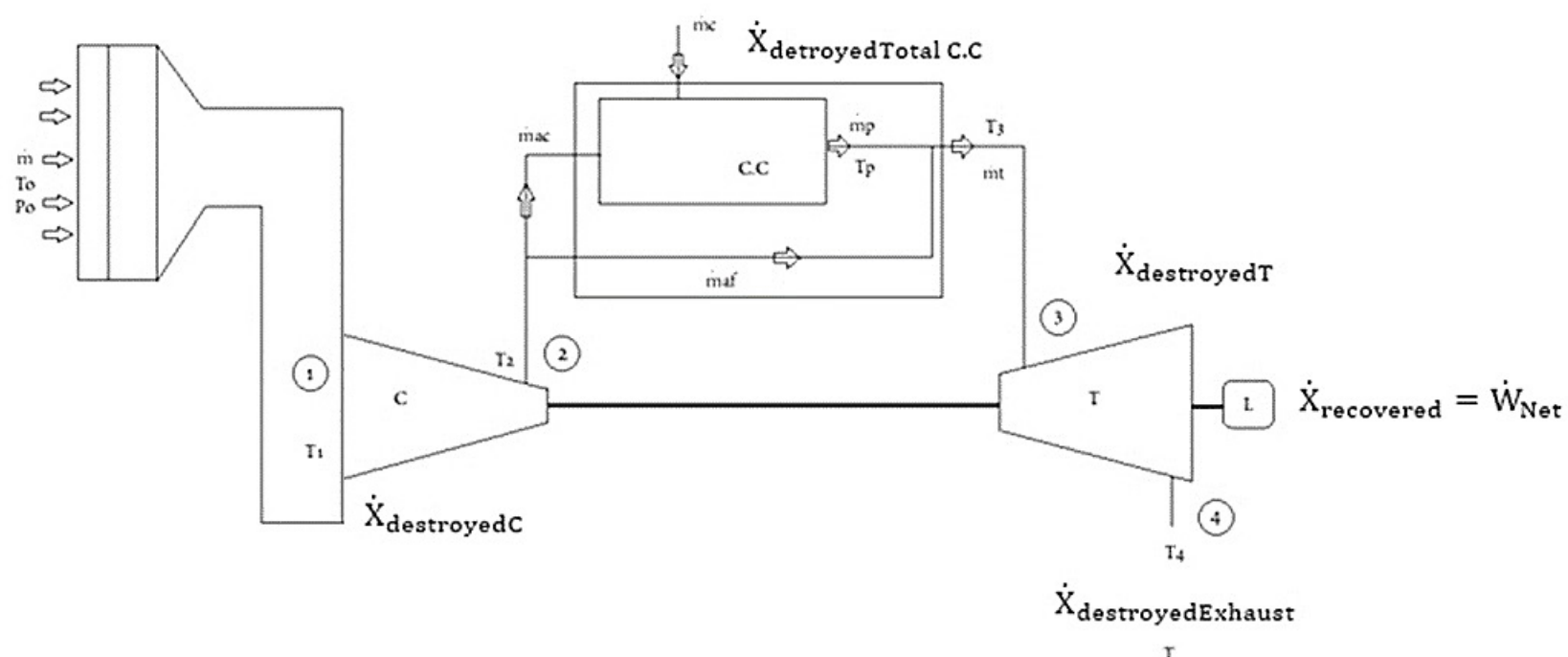

Fig. 9. Total destroyed exergy.  
Source: Authors.

Accordingly, total destroyed exergy is defined by (46):

$$\dot{X}_{\text{destroyedTotal}} = \dot{X}_{\text{destroyedC}} + \dot{X}_{\text{destroyedTotal C.C}} + \dot{X}_{\text{destroyedT}} + \dot{X}_{\text{destroyedExhaust}} \quad (46)$$

Recapping:

$$\dot{X}_{\text{destroyedC}} = \dot{W}_C - \dot{W}_{\text{revC}} : [\text{kW}]$$

Destroyed exergy in the compressor:

$$\dot{X}_{\text{destroyedTotal C.C}} = \dot{X}_{\text{destroyed C.C}} + \dot{X}_{\text{destroyed Mixing}} [\text{kW}]$$

Destroyed exergy in the combustion chamber:

$$\dot{X}_{\text{destroyedT}} = \dot{W}_{\text{revT}} - \dot{W}_T [\text{kW}]$$

Destroyed exergy in the turbine:

$$\dot{X}_{\text{destroyedExhaust}} [\text{kW}]$$

Destroyed exergy by the flue gases

Second law efficiency for the complete system is defined by (47):

$$\eta_{\text{II SysTotal}} = 1 - \frac{\dot{X}_{\text{destroyedTotal}}}{\dot{X}_{\text{Expended}}} \quad (47)$$

The expended exergy is (48):

$$\dot{X}_{\text{Expended}} = \dot{X}_{\text{recovered}} + \dot{X}_{\text{destroyedTotal}} \quad (48)$$

The recovered exergy is (49):

$$\dot{X}_{\text{recovered}} = \dot{W}_{\text{Net}} \quad (49)$$

### III. RESULTS AND DISCUSSION

Net power output decreases provided that ambient temperature increase (Fig. 10). There is a representative fraction of power loss due to operation far away designing point at 15°C. It is relevant to compact in one sketch the ambient temperature variation influence in some operating parameters of the cycle.

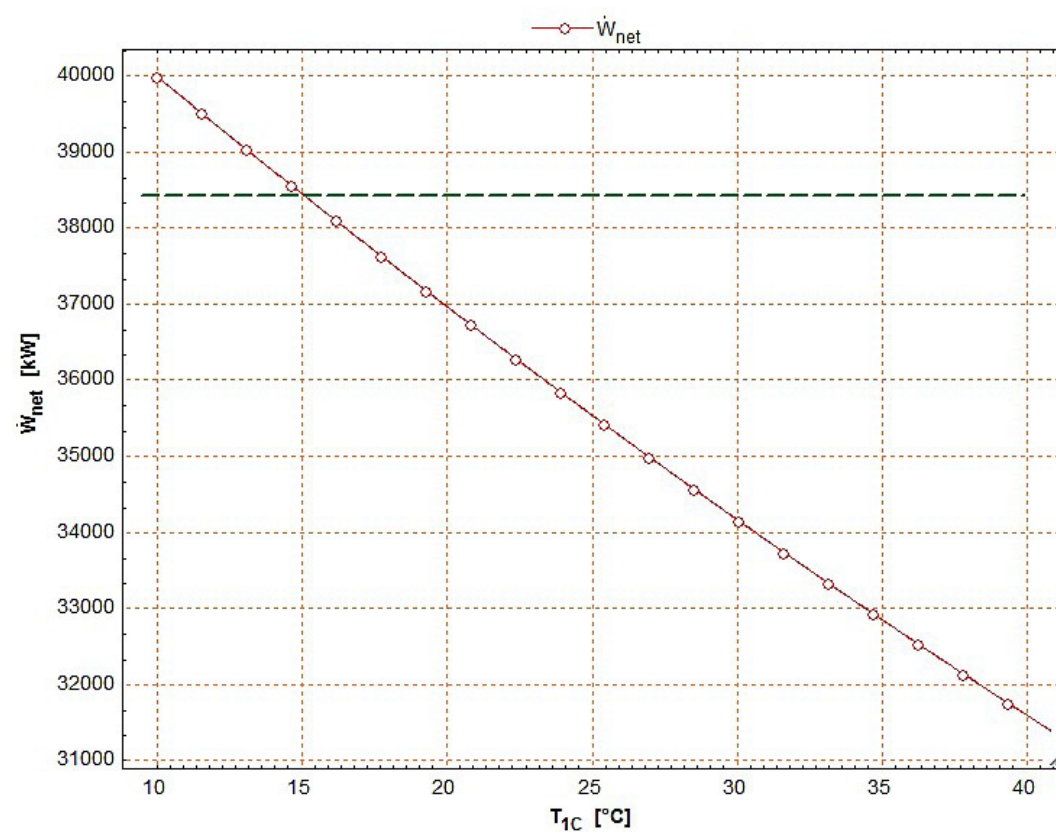

Fig. 10. Power output as function of inlet air temperature.  
Source: Authors.

Fig. 11 shows the ratio variation referring to the ISO conditions. It represents the impact of compressor inlet temperature in the overall performance of gas turbine power plant where relevant operation parameters have been taken into account, relative values to ISO conditions in percentage were delineated.

On the one hand, heat rate, HR, and exhaust temperature,  $T_4$ , increase as inlet temperature increases. Conversely, first law efficiency,  $\eta_1$ , mass air flow,  $\dot{m}_m$  and power output  $\dot{W}_{Net}$  decreases as inlet temperature is higher than ISO standard reference point. Higher temperature values impact negatively the system performance.

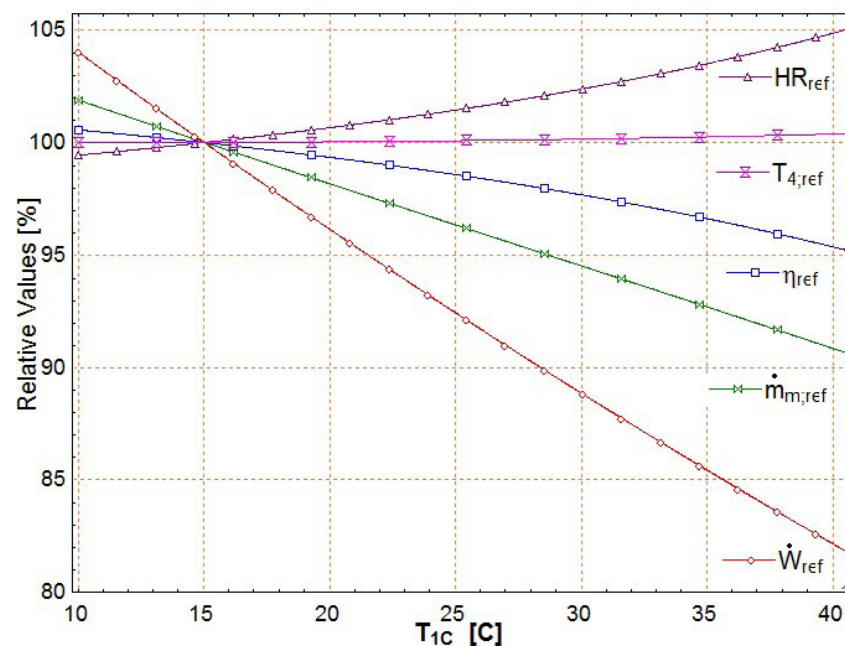

Fig. 11. Overall performance as function of compressor inlet temperature. Source: Authors.

Clearly the power output and cycle efficiency are negatively impacted, we observe a decrease of up to approximately 18% of power losses in relation to the optimal design point.

An important consideration regarding the operation of thermal plants, based on natural gas as fuel, is the impact of height above sea level (m.a.s.l.). Elevated altitudes reduce the density of the air and consequently the mass flow that leads to a drop-in power. With the increase in altitude, as a rule, the power drop is approximately 3% to 4% per 1000 ft of altitude arrangement [12]. Fig. 12 shows this tendency at different meters above sea level, 0, 500 and 1000 meters are shown.

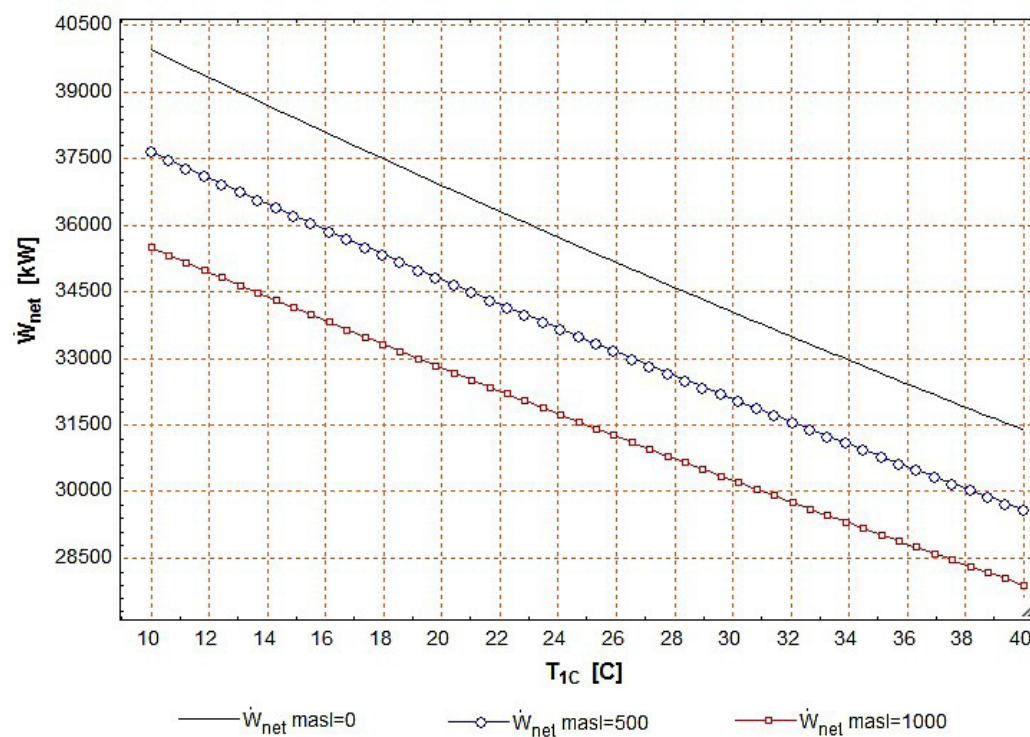

Fig. 12. Height above sea level Impact of on net power output. Source: Authors.

### A. Compressor

The compression power demanded by this device has a strong tendency to increase as the ambient temperature is higher, this is justified by the increase in the specific volume or decrease in the density of the working fluid at the entrance of the cycle. One way to minimize the consumed power is decreasing the specific volume of the gas, this is achieved lowering the inlet temperature by some method of cooling economically viable. A representation of the compressor discharge temperature  $T_2$ , equation (1) assuming constant specific heats, compared with the exact calculation given by equation (3) in which the discharge temperature of the compressor is determined indirectly from the enthalpy  $h_{2a}(T_{2a})$  is shown in Fig. 13.

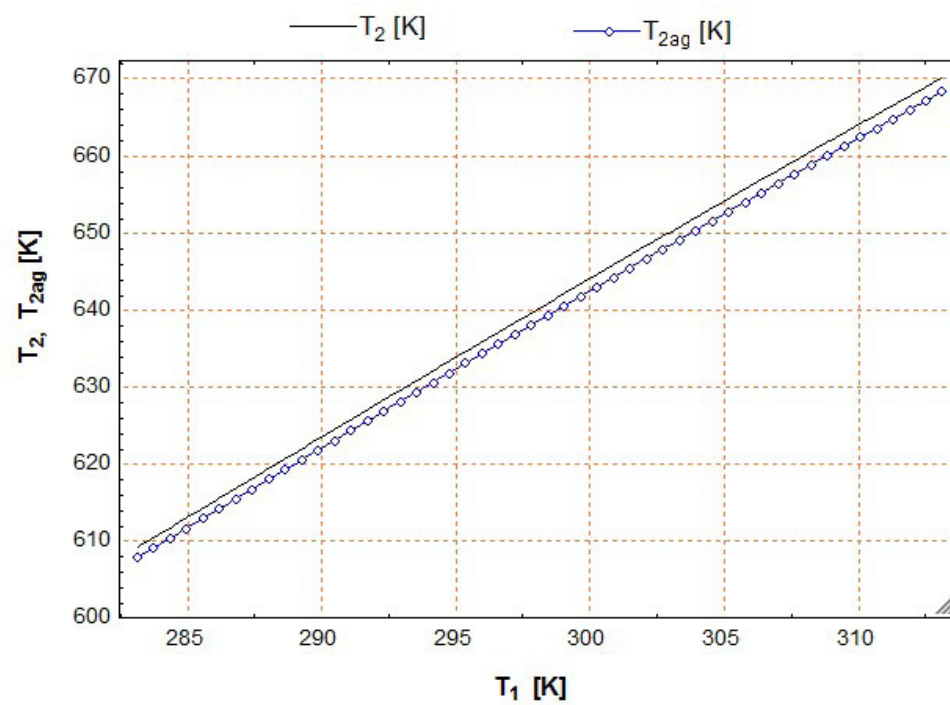

Fig. 13. Compressor discharge temperature.  
Source: Authors.

The power demanded by the compressor is simulated in Fig. 14.

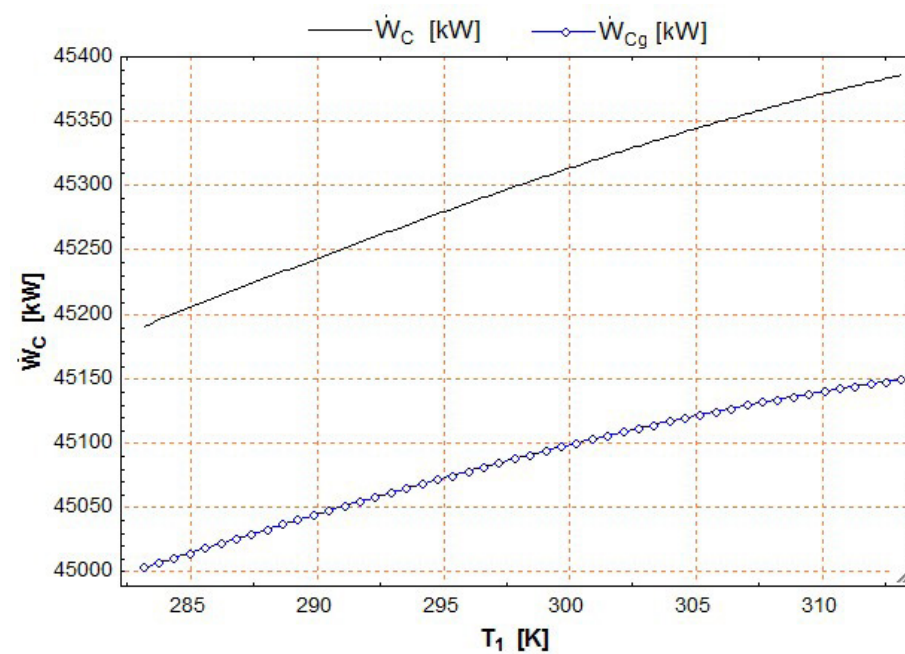

Fig. 14. Demanded power by the compressor.  
Source: Authors.

As the temperature is lower we can obtain a lower consumption in this working consumer device, the power has been plotted for the approximation of constant specific heats  $\dot{W}_c$  [kW] and the exact calculation  $\dot{W}_{cg}$  [kW], the absolute error by both calculation method is in the range of 0.4% to 0.5%. Destroyed exergy in the compressor is shown on Fig. 15.

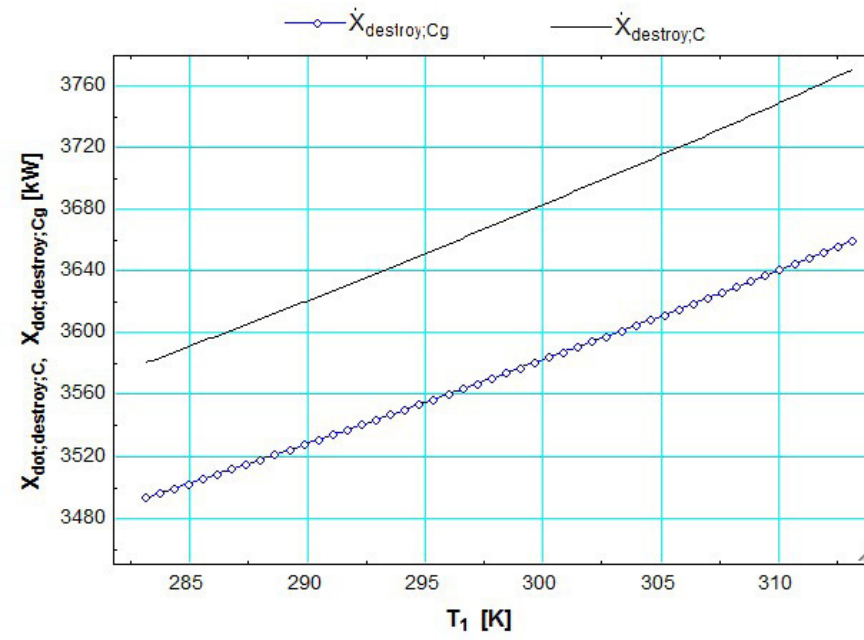

Fig. 15. Exergy destroyed as function of compressor inlet temperature. Source: Authors.

Undoubtedly, irreversibilities tends to augment at elevated temperature. Thus, second low efficiency must tend to improve at lower temperatures as Fig. 16 illustrates.

Second-law-efficiency for such a work consuming device like the compressor represents the ratio by the minimum work and useful input work which means that less input of work is required for compress the gas to a final fixed state when inlet compressor temperature tends to decline.

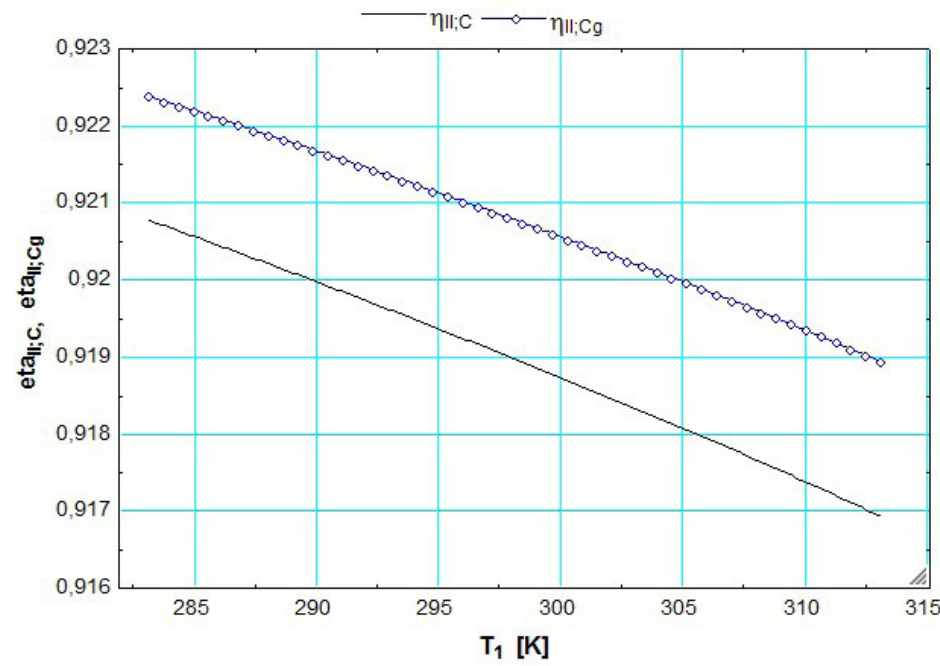

Fig. 16. Second law efficiency in the compressor vs. ambient temperature. Source: Authors.

### B. Combustion chamber

It is necessary to apply the chemical equilibrium criterion to all possible reactions that may occur in the combustion chamber. To validate the combustion model proposed in EES, a parallel calculation was developed with NASA's CEA (Chemical Equilibrium with Applications) software, which calculates equilibrium compositions and properties of complex mixtures for any set of reactants. Fig. 17 shows the adiabatic temperature as a function of the excess of air. Mathematical model results got in EES are compared with the CEA of NASA. Also, detailed product composition is shown in the same figure for each constituent (Fig. 18; Fig. 19; Fig. 20; Fig. 21; Fig. 22; Fig. 23).

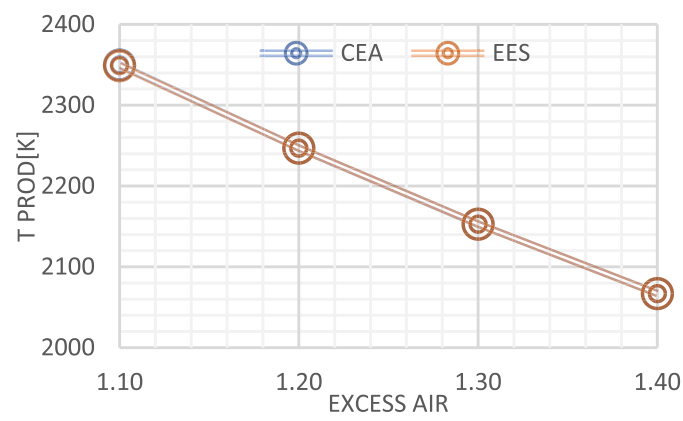

Fig. 17. Adiabatic flame temperature vs. excess air, CEA vs. EES.  
Source: Authors.

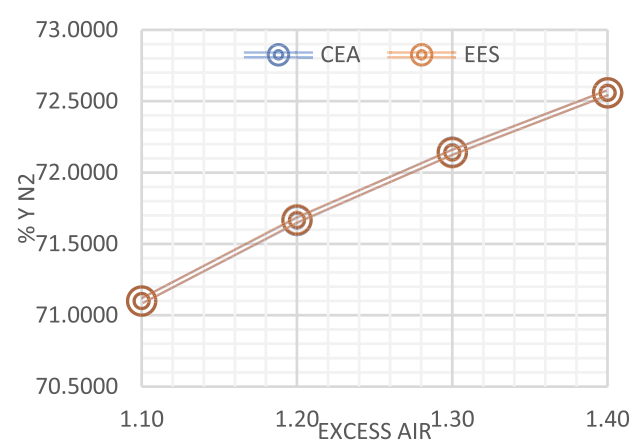

Fig. 18. N2 molar percentage, CEA vs. EES.  
Source: Authors.

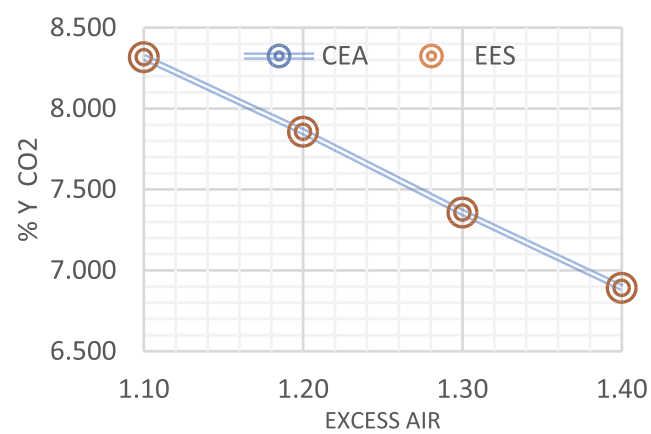

Fig. 19. CO2 molar percentage, CEA vs. EES.  
Source: Authors.

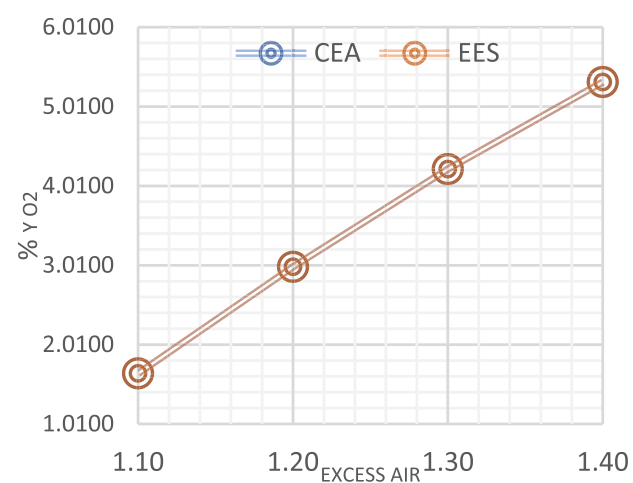

Fig. 20. O2 molar percentage, CEA vs. EES.  
Source: Authors.



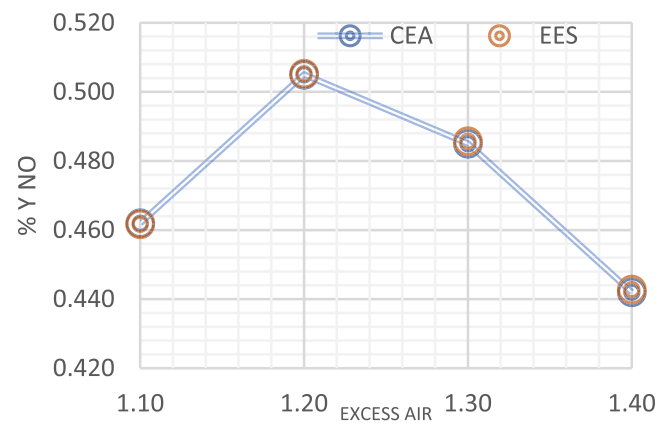

Fig. 21. NO molar percentage, CEA vs. EES.  
Source: Authors.

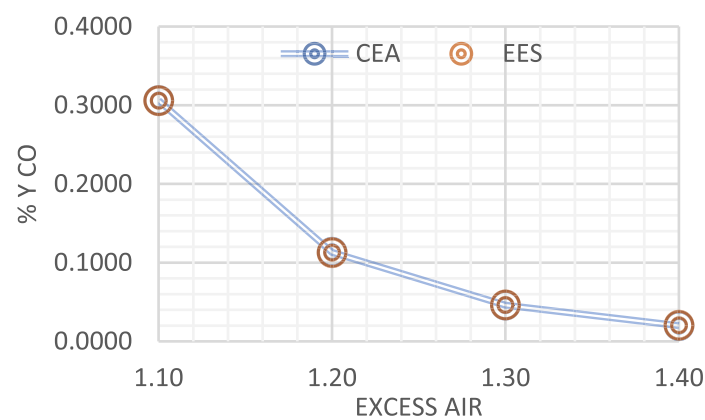

Fig. 22. CO molar percentage, CEA vs. EES.  
Source: Authors.

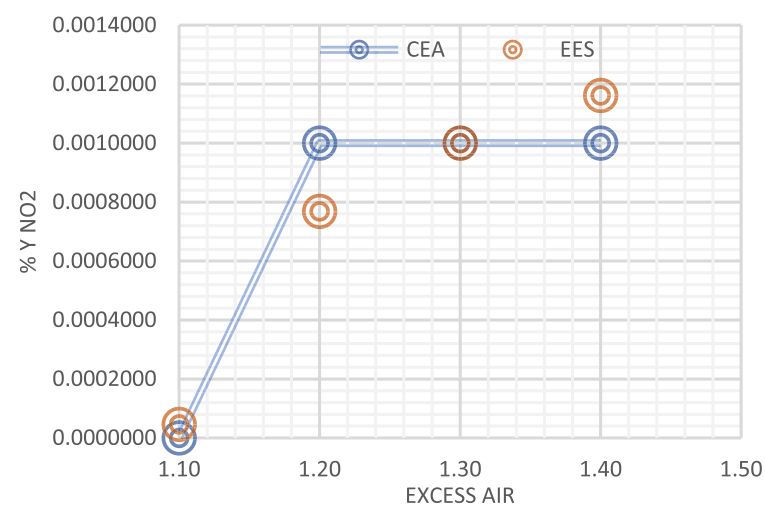

Fig. 23. NO2 molar percentage, CEA vs. EES.  
Source: Authors.

NASA's CEA theoretical results are used as a reference of the molar fraction of combustion products, an excellent result has been obtained with the program proposed in the EES, as can be compared both data in the same figure per each component, the errors are practically null.

Total demolished energy on combustion process and mixing process is described on Fig. 24. Evidently, combustion processes are extremely irreversible. This process involves no actual work. No matter how compressor inlet temperature is, destroyed exergy remains high in the combustion chamber in comparison to compressor and turbine exergy diminished.

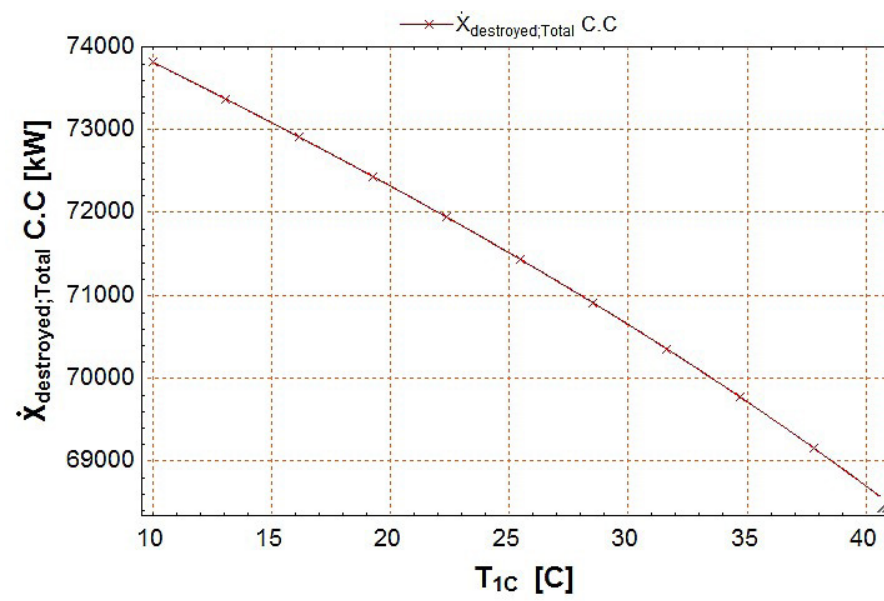

Fig. 24. Total demolished exergy on combustion chamber as function on compressor inlet temperature.  
Source: Authors.

### C. Gas turbine

The extracted power by the turbine is plotted in Fig. 25, as the inlet temperature is lowered we can extract a greater amount of power from the device, the power has been plotted for the approximation of constant specific heats,  $\dot{W}_T$  [kW] and the calculation exact method  $\dot{W}_{Tg}$  [kW], the absolute error of the approximate calculation method is in the range of 0.4% to 0.5%.

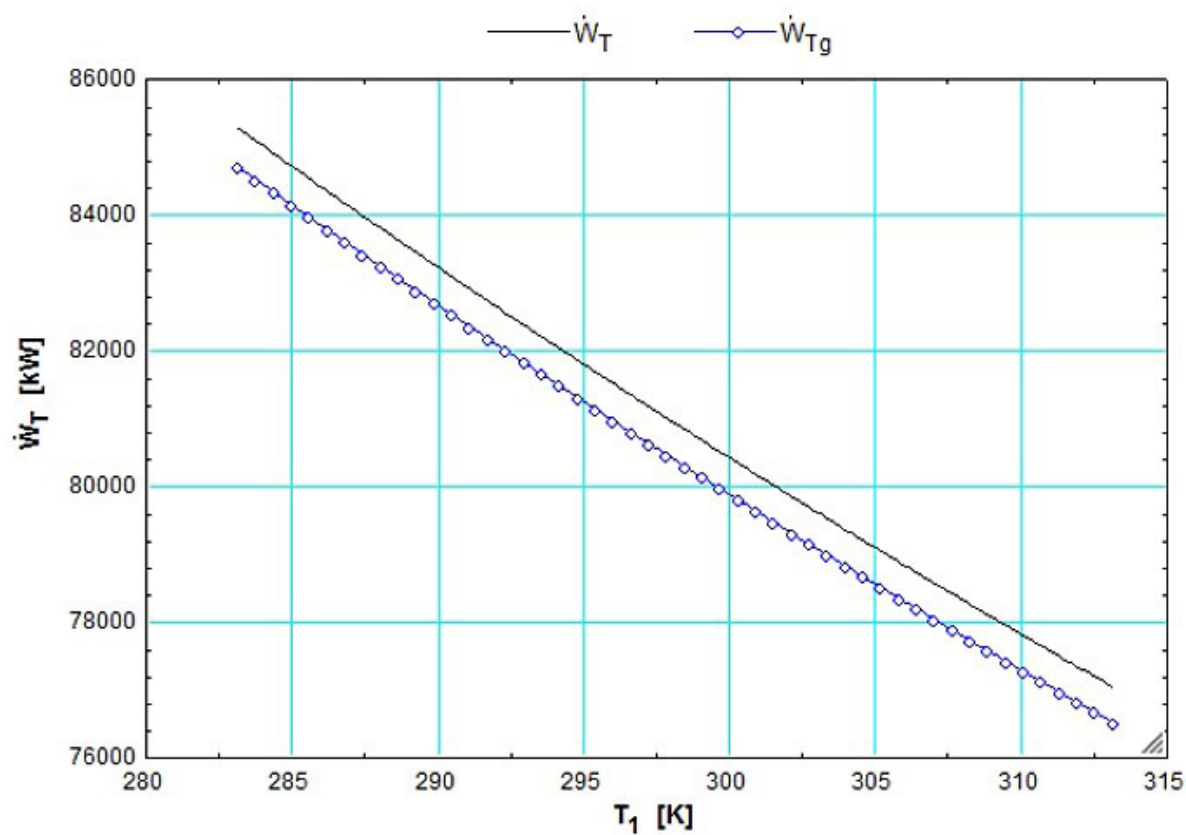

Fig. 25. Extracted power by the turbine.  
Source: Authors.

While second law efficiency for the turbine is shown on Fig. 26. It has a similar behaviour as compressor efficiency which its trend is to enhance as compressor inlet temperature goes down.

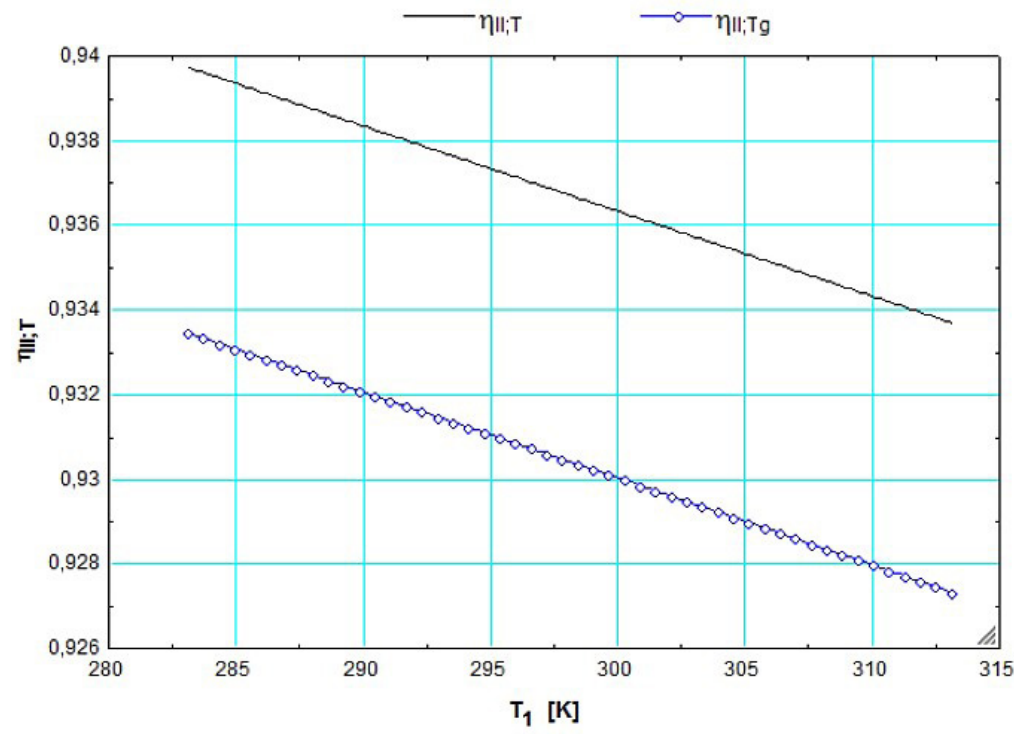

Fig. 26. Second law turbine efficiency as function of compressor inlet temperature. Source: Authors.

It is evident a better use of the power extraction capacity in the turbine, leading to an increase in the second law efficiency, the results of the two calculation methods are again compared.

#### D. Exergy destroyed by the exhaust gases of the turbine

It is also important to consider the exergy destroyed during the heat rejection process of the exhaust gases to the environment after expansion in the turbine, since the gas temperatures are of the order of 800 [K], as shown in Fig. 27.

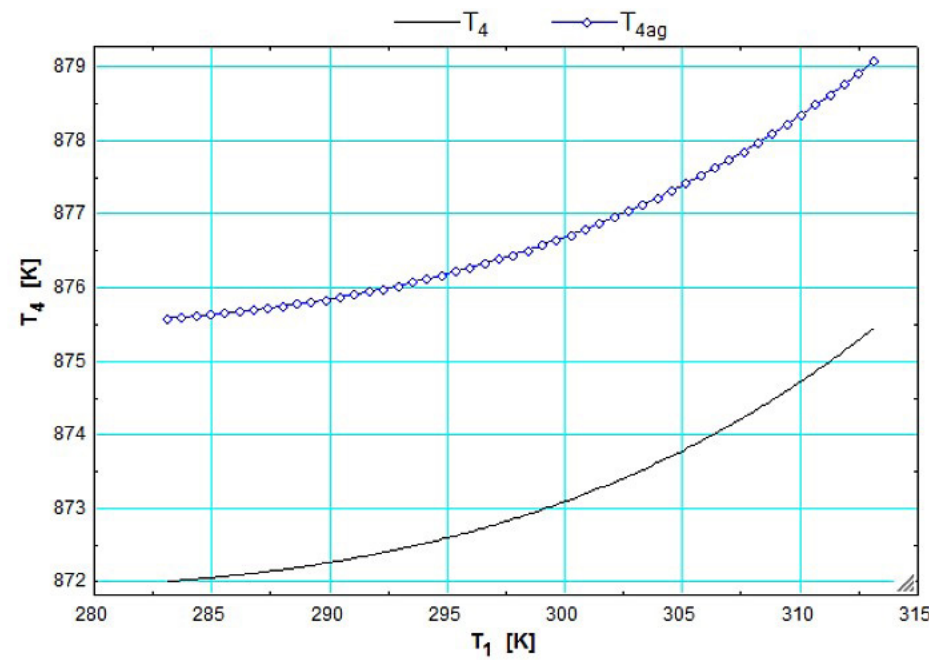

Fig. 27. Flue of gases temperature after expansion in the turbine. Source: Authors.

Although  $T_4$  is reduced when inlet air to the system is cooled, the heat transfer pace that could be achievable by a Heat Recovery Steam Generator, HRSG is faster. Therefore, the work per unit of time that would realize an ideal thermal machine that operates between the discharge temperature of the exhaust gases of the turbine and the ambient temperature is shown in Fig. 28.

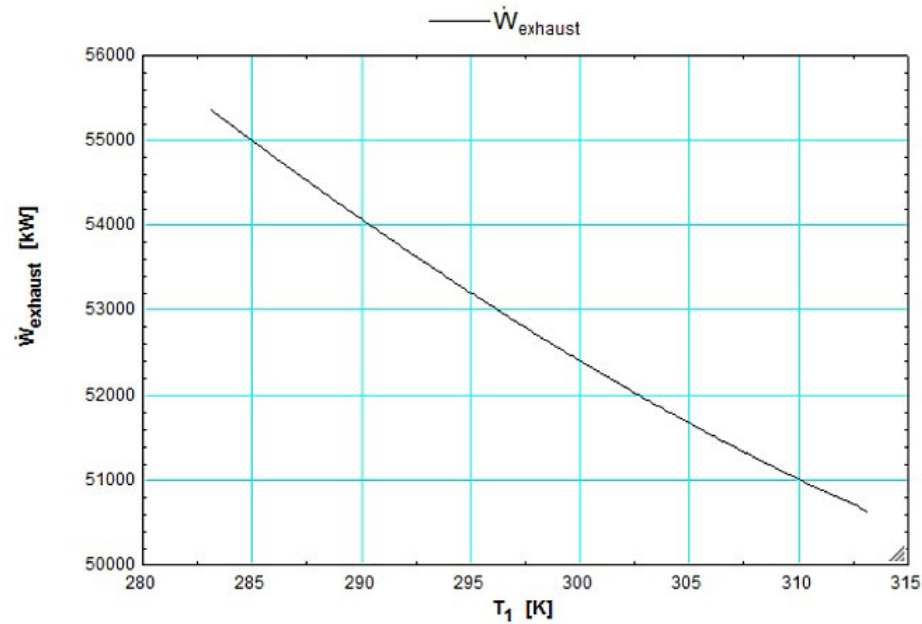

Fig. 28. Power ideal thermal machine recovering energy exhaust gases.  
Source: Authors.

This waste of energy must be considered in the whole system. The trend of Fig. 28 is theoretically in accordance with the operation of real machines in combined cycle operating with a cooling system at the entrance of the cycle [8]:

“The increase of the air flow in the compressor and consequently the increase of the flow rate of the exhaust gases due to the cooling of input to the inlet also increases the rejection of heat from the gas turbine and is beneficial for the operation in combined cycles [8, p. 399].”

#### E. Second law efficiency and destroyed exergy of the whole system

To visualize the improvement in the whole system by cooling the air entering the compressor it is necessary to simulate what would be the expended, destroyed and recovered exergy in the complete system, this representation is sketched in Fig. 29, where it is evident the increase of the exergy recovered by the system as the entry temperature to the compressor decreases.

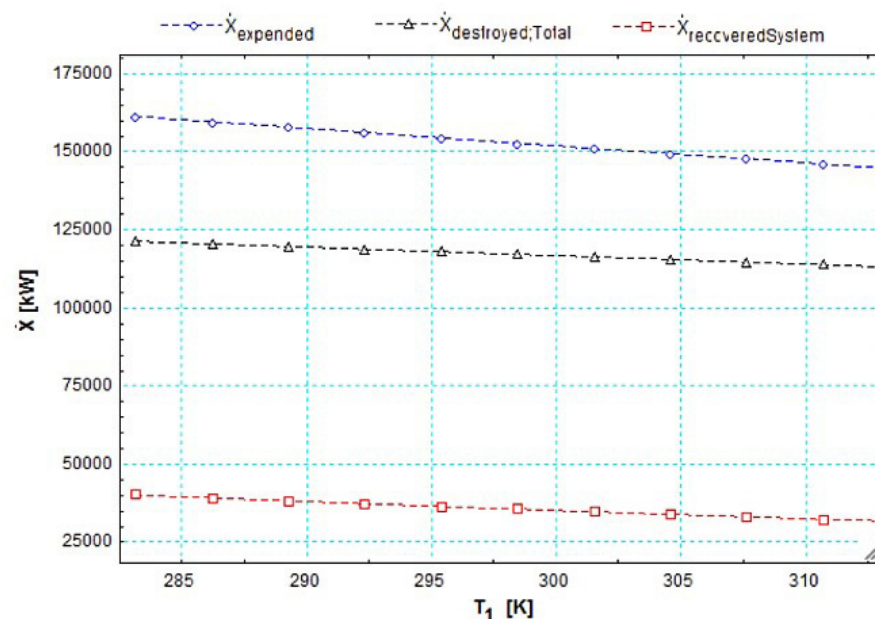

Fig. 29. Recovered, destroyed and available exergy from the global system.  
Source: Authors.

It is clear that the exergy availability or exergy provided is also superior, this is related to the increase in air flow and fuel required, the destroyed exergy also increases, but the quality of the use of energy showed by second law efficiency, where its tendency justifies or not the implantation of an air cooling system is successfully depicted in the Fig. 30.

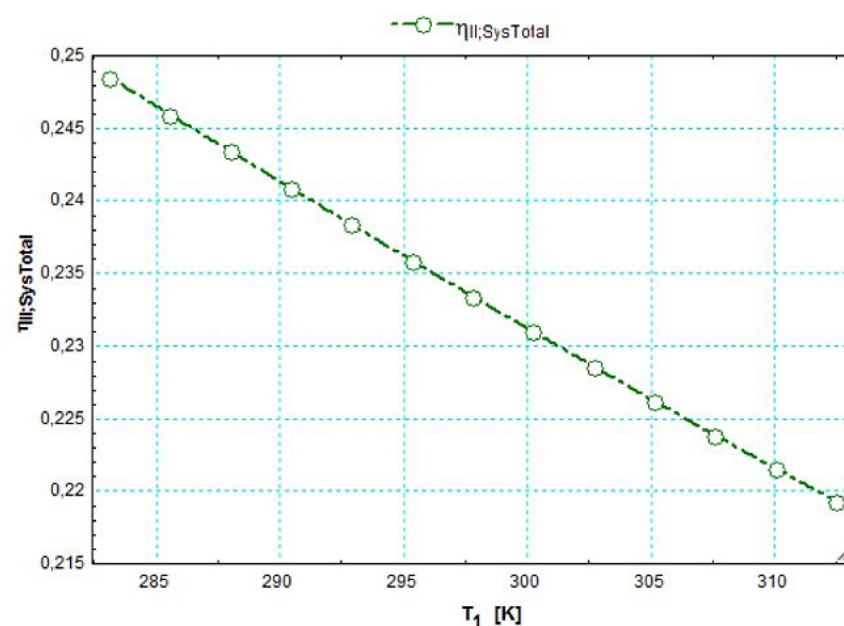

Fig. 30. Second law efficiency.  
Source: Authors.

#### IV. CONCLUSIONS

The modified Brayton cycle presented, allows to determine the main operating parameters by means of an energy and exergy analysis, in order to be able to carry out its study from two different points of view, such as the conservation of energy and degradation of the quality of the energy.

The inlet air temperatures in the compressor above 15°C demonstrates the negative impacts in the power output losses of the system, the power generated decreases considerably as the temperature moves away from the ISO design conditions, near 40°C can have soaring power losses.

The second law efficiency that describes the concept of energy quality considers all the devices and processes that are carried out in the simulated cycle, second law efficiency has a tendency to increase as the entry temperature to the compressor decreases, this simulation demonstrates by a means other than the first law the justification for the implementation of a cooling system in a gas turbine to recover the lost power.

To counteract these negative effects, air cooling at the entrance of the compressor is proposed, technological solution defined as TIAC (Turbine Inlet Air Cooling) which helps to stabilize the power output and decrease the heat rate of the system [8].

#### ACKNOWLEDGMENTS

Special acknowledgements to Doctor Gerardo Gordillo who has fully supported this investigation, an also foreseen a real and possible application on the industry, meshing academy concepts to applicable technology solutions based on thermodynamic principles.

#### REFERENCES

- [1] A. A., El-Shazly, M. Elhel., M. M., Sorour & W. M. El-Maghlany, "Gas turbine performance enhancement via utilizing different integrated turbine inlet cooling techniques", *Alex Eng J*, vol. 55, no. 3, pp. 1903–1914, 2016. <https://doi.org/10.1016/j.aej.2016.07.036>
- [2] S. Oyedepo y O. Kilanko, "Thermodynamic Analysis of a Gas Turbine Power Plant Modelled with an Evaporative Cooler", *IJoT*, vol. 17, no. 1, pp. 14–20, 2014. <https://doi.org/10.5541/ijot.76988>
- [3] W. H. Al-Tara, "Performance of a gas turbine with impact cycle temperatures trough exergy analysis", *IJNTR*, vol. 2, no. 5, pp. 139–143, 2016. Available: <https://www.ijntr.org/performance-of-a-gas-turbine-with-impact-cycle-temperatures-through-exergy-analysis>
- [4] Y. Cengel & M. Boles, *Thermodynamics-An Engineering Approach*, 8<sup>th</sup> ed. NY, USA: McGraw-Hill, 2015.
- [5] V. Tara, S. Ravi & C. Raganraya, "Exergy analysis of gas turbine power plant", *IJETT*, vol. 4, no. 9, pp. 3991–3993, 2013. Available: <http://ijettjournal.org/archive/ijett-v4i9p156>
- [6] T. Giampaolo, "Gas Turbines Inlet Treatment", in *Gas Turbine Handbook Principles and practices*, 3 Ed. Indian Trail, Georgia, USA: The Fairmont Press, 2006.
- [7] P. Boyce, "An Overview of Gas Turbines. Major Gas Turbine Components, Combustors", in *Gas Turbine Handbook*. Houston, Texas, USA: Butterworth-Heinemann, 2002, pp. 33–36.

- [8] A. M. Y. Razak, “Power Augmentation”, in *Industrial Gas Turbines, Performance and operability*. BR, FL, USA: CRC Press, 2007, pp. 376–408. <https://doi.org/10.1533/9781845693404.2.376>
- [9] H. I. H. Saravanamuttoo, G. F. C. Rogers & H. Cohen, “Shaft power cycles”, in *Gas Turbine Theory*. England: Pearson Education Limited, 2001, pp. 56–57.
- [10] C. Rotaru, M. Mihaila, G. Matei & I. Edu, “Thermodynamic performances of the turbojet combustion chambers – numerical evaluation”, presented at the *International Conference on Mechanics, Fluid Mechanics, Heat and Mass Transfer*, MFMHMT, ZIN, CH, 2014.
- [11] A. Bejan, “Lost Available Work”, in *Advance Engineering Thermodynamics*. HOB, USA: John Wiley & Sons, 2006, pp. 102–104.
- [12] C. Meher-Homji, M. Chaker & H. M. Motiwala, “Motiwala, Gas turbine performance deterioration”, presented in *The 30th turbomachinery symposium*, UT, Austin, USA, 2001, pp. 139–176. <https://doi.org/10.21423/R18Q00>

**Daniel Eduardo Forero Florian** is an innovative qualified mechanical engineer with over seven years experience as a mechanical engineer with affairs related to power transmission belts, conveyor belts, thermoplastic materials, gas turbine Inlet Air Cooling (TIC). Specialized in turbomachinery and reciprocating compressors, energy conversion, thermodynamics, heat transfer, and fluid mechanics. Knowledge of Vibration Analyses, Engineering Equation Solver (EES), MS Office, Solid Works, Wolfram Mathematica software. <https://orcid.org/0000-0001-5028-6607>