

Techno-economic evaluation and conceptual design of a liquid biofertilizer plant

Evaluación técnico-económica y diseño conceptual de una planta de biofertilizantes líquidos

*Amaury Pérez Sánchez**, *Sonali Singh***, *Eddy Javier Pérez Sánchez**, *Rutdali Maria Segura Silva****

DOI: 10.15446/rev.colomb.biote.v20n2.77053

ABSTRACT

Biofertilizers have become an effective, eco-friendly and low cost alternative to chemical fertilizers. Process engineering and cost models for a biofertilizer plant with a production capacity of 44 tons of liquid biofertilizer per year (568 kg/batch) were developed. The models were obtained using process simulator (*SuperPro Designer*®), version 8.5 (Intelligen, 2012), while the 3D conceptual design and layout of the biofertilizer plant was developed with (*OptiPlant*®) software (ASD Global, 2015). The total capital investment required to erect the plant is \$ 3 975 000, the unit production cost of one 1.5 L bottle of liquid biofertilizer is \$ 24.009, while the economic indicators *Net Present Value* (NPV) and *Internal Rate of Return* (IRR) had values of \$ 716 000 and 2.55%, respectively. Also, the total revenues are \$ 985 000/year, the *Return on Investment* (ROI) is 14.93 %, and the payback time is 6.70 years.

Key words: Biofertilizer, simulation, conceptual design, economics

RESUMEN

Los biofertilizantes se han convertido en una alternativa de bajo costo, efectiva y amigable con el medio ambiente en comparación con los fertilizantes químicos. En el presente trabajo se desarrollaron los modelos de ingeniería de proceso y costo de una planta de biofertilizantes líquidos con una capacidad de 44 toneladas por año (568 kg/lote). Los modelos fueron obtenidos empleando el simulador de procesos *SuperPro Designer*® versión 8.5 (Intelligen, 2012), mientras que el diseño conceptual en 3D y dimensionamiento de la planta se desarrolló mediante el software *OptiPlant* (ASD Global, 2015). Se requiere una inversión total de USD \$ 3 975 000 para erigir la planta, el costo de producción unitario de una botella de 1,5 L de biofertilizante líquido es de USD \$ 24,009, mientras que los indicadores económicos Valor Actual Neto (VAN) y Tasa Interna de Retorno (TIR) tuvieron valores de USD \$ 716 000 y 2,55 %, respectivamente. También se obtienen ganancias totales de USD \$ 985 000/año y un valor del Período de Retorno de la Inversión de 6,70 años.

Palabras claves: Biofertilizante, simulación, diseño conceptual, costos.

Recibido: diciembre 10 de 2017 **Aprobado:** octubre 26 de 2018

* Departamento de Química; Facultad de Ciencias Aplicadas; Universidad de Camagüey. Carretera Circunvalación Norte, Km. 5½, e/ Camino Viejo de Nuevitas y Ave. Ignacio Agramonte, Camagüey, Cuba. CP 74650. amaury.psanchez@reduc.edu.cu

** ASD Global, 1371 Oakland Blvd Ste 100; Walnut Creek; CA 94596. United States of America. sonali.singh@asdglobal.com. Fax: 925-975-0696.

*** Centro de Ingeniería Genética y Biotecnología (CIGB) de Camagüey. Circunvalación Norte y Avenida Finlay. Apartado Postal 387. ruthdaly.segura@cigb.edu.cu.

INTRODUCTION

It's well known that a considerable number of bacteria are capable to exert a beneficial effect on plant growth. Plant Growth Promoting Bacteria (PGPB) is a term used to define soil bacteria which can promote, under adequate environment conditions, plant growth and crops productivity. Although they are found naturally in soil and plant roots, they will produce the expected agronomical results only if applied effectively, under optimum conditions, on seeds or plant roots, increasing crops yield between 5–30 % (Prabavathy *et al.*, 2007). *Azospirillum brasilense* is a Gram negative, aerobic, nitrogen fixer, natural living PGPB usually found in plant roots surface and soil, which fixes around 20–40 kg of atmospheric nitrogen per hectare (Okon and Vanderleyden, 1985; Prabavathy *et al.*, 2007). It's also capable to produce and secrete plant growth-regulating hormones (phytohormones) such as auxins, cytokines vitamins and gibberellins which are very important for plant development (Spaepen *et al.*, 2009).

It's extensively studied bacteria both at laboratory level and industrial scale, and can be applied in popular crops like rice, sugarcane, maize, wheat, banana, coffee, coconut, pearl millet and lime (Tien *et al.*, 1979; Baldani *et al.*, 1983; Mishra and Dadhich, 2010; Roldán *et al.*, 2013).

Biofertilizers constitute active products or microbial inoculants of bacteria, algae and fungi, either combined or separate, which enhance the nutrients availability in plants thus increasing crops yield and productivity. They can add almost all the nutrients usually consumed by plants, through a natural process of atmospheric nitrogen fixation, phosphorous solubilization and plant growth stimulation through the synthesis of Growth Promoting Substances (Prabavathy *et al.*, 2007).

Any common liquid biofertilizer production process consists of three different stages or steps (Gódia and López, 1989) (Fages, 1992) (Prabavathy *et al.*, 2007):

- 1) Bacteria Propagation: Mass multiplication of the strain selected until desired inoculum concentration and volume are reached;
- 2) Bacteria Cultivation: Fermentation of the bacterial strains in large, industrial size fermentors, until desired cell concentration is reached; and
- 3) Bacteria Recovery/*Formulation/Packing*: The bacteria contained within the fermentation broth are recovered, either by centrifugation or filtration, and then formulated using formulation substances. The formulation liquid containing the latent cells is finally poured in plastic bottles.

In chemical process industries (CPI), the simulation approach constitutes an important and indispensable tool mostly used to design, assess, optimize and analyze projects, systems and processes (Biwer and Heinzle, 2004; Farid, 2007; Krajnc *et al.*, 2007; Kwiatkowski *et al.*, 2006). The application of process simulators, software and computer programs throughout the CPI regardless type and/or capacity, has grown exponentially during the last decade, while some important simulation packages and software like *SuperPro Designer*[®], *Hysys*[®], *Aspen Plus*[®], *Chemcad*[®], etc., are commercially available today and extensively used in almost all stages of process design and development, in order to design/characterize either new or already established chemical processes; evaluate techno-economic alternatives; optimize processes, unit operations and systems; visualize 3D layouts; as well as to determine important global parameters of the process under study such as profitability, productivity, efficiency, net incomes, saving possibilities, etc. (Ernst *et al.*, 1997; Rouf *et al.*, 2001; Marchetti *et al.*, 2008; Ramirez *et al.*, 2008; Dimian and Bildea, 2008).

At the present work, engineering and economics models were developed for the conceptual design of a liquid biofertilizer production plant, in order to use them as a research tools to aid in the research, analysis and optimization of the production process and also to assist in future process improvements and developments. The models were obtained using the simulation package *SuperPro Designer*[®], version 8.5 (Intelligen, 2012) and the *OptiPlant*[®] software (ASD Global, 2015) for 3D visualization and layout of the proposed biofertilizer plant. The information used to design the liquid biofertilizer plant was obtained from various sources, including equipment and raw materials suppliers, industry experts, academic publications and technical documents.

MATERIALS AND METHODS

Microorganism selection

The bacteria selected was *Azospirillum brasilense*, since it's one of the most worldwide used microorganism for biofertilizer production due to its high capabilities for nitrogen fixation and solubilizing phosphorous, secrete plant growth-promoting hormones such as auxins, cytokines vitamins and gibberellins, and also because it can increase plant growth yield by 35%, and has a high resistance to changing environmental conditions.

Process description

The conventional production process of a liquid biofertilizer consists of three well-defined stages or steps (figure 1). In the first step, known as Bacteria Propaga-

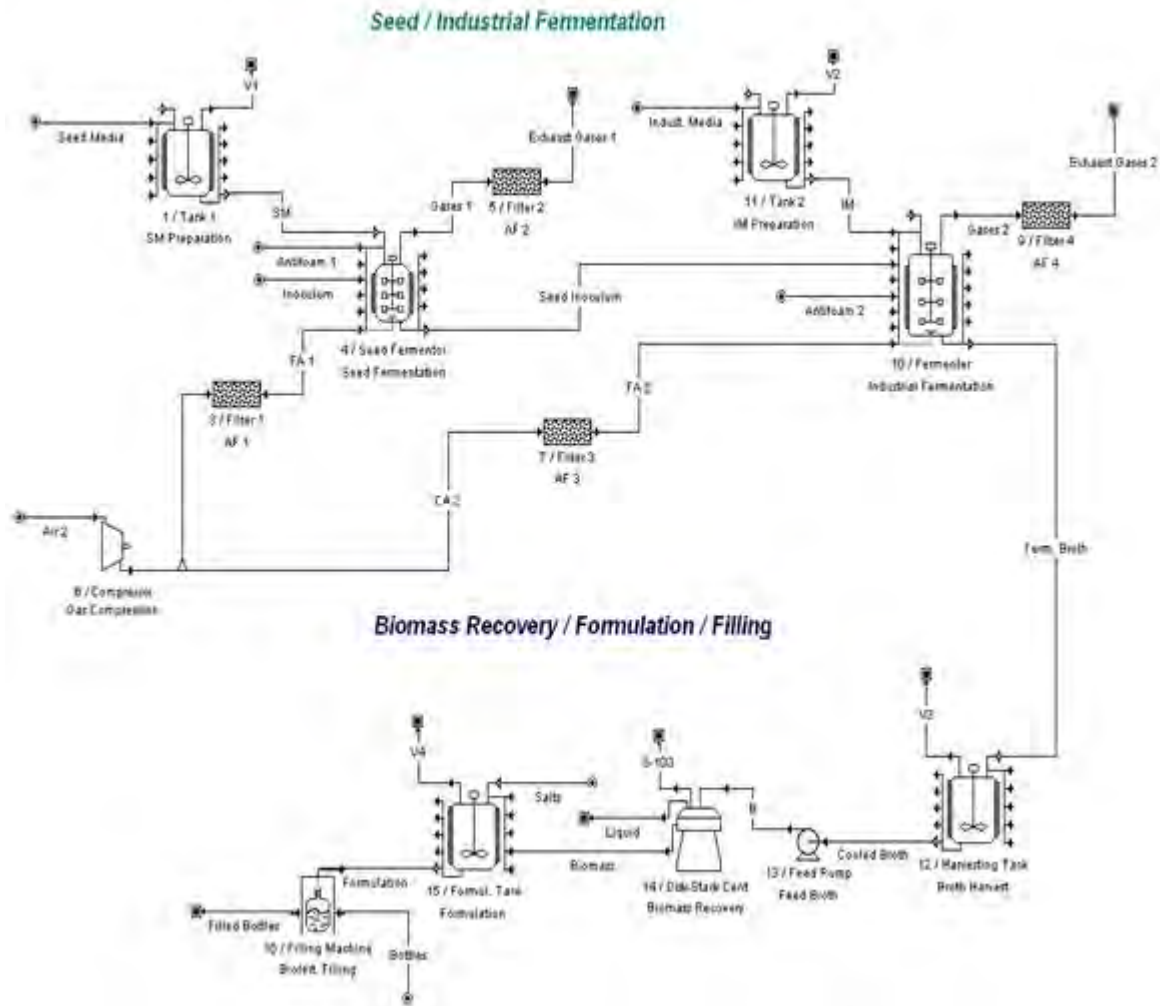

Figure 1. Simplified flow diagram of the liquid biofertilizer production plant (SuperPro Designer®, 2012).

tion, the bacteria are cultivated in flasks of different volume which contains a specific culture media, until the desired cell concentration is achieved. Once this expected cell concentration is reached, the liquid culture containing the living cells (pre-inoculum) are transferred (inoculated) to the larger volume flasks containing the culture media. The inoculum volumes commonly used are: 250 mL, 500 mL, 3 L and 5 L. When in the 5 L inoculum flask a cell concentration of 10^9 cells per mL is achieved at the following conditions: $32\text{ }^\circ\text{C}$ of temperature, 250 rpm of agitation and pH of 6.0, the entire volume of the final propagation flask (5 L) is inoculated to the seed fermenter, thus indicating that the second process step (Bacteria Cultivation) is just starting. At the same time that the cells are being propagated in the culture flasks, the culture media to be used both at seed and industrial fermenters are being prepared, sterilized and cooled within the same fermenters, prior to inocu-

lation with propagated cells. The 5 L final propagation inoculum is transferred to 20 L of a specific, previously sterilized culture media contained inside of the seed fermenter, thus starting the seed fermentation step. This step usually lasts for 24 - 55 hours, until a cell population load higher than 10^9 cells/mL is obtained. The seed fermentation is carried out at $30\pm 2\text{ }^\circ\text{C}$, 400 rpm, pH of 6.0 and 1.0 v.v.m of aeration rate. Once finished the seed fermentation step, the cell suspension contained within the seed fermenter is inoculated to the industrial fermenter, which already contains about 225 L of a previously sterilized culture media. The industrial fermentation process proceeds at $30\pm 2\text{ }^\circ\text{C}$, 600 rpm, pH of 6.2 and 1.5 v.v.m of aeration rate, and has a duration time of about 3 - 4 days, which is the standard period to obtain a cell concentration higher than 10^9 cells/mL at the industrial fermentation broth. At this point the third and last process step (Bacteria Recovery/Formulation/

Table 1. Characteristics and acquisition cost of the main equipment used in the production process.

Equipment	Amount	Characteristics	Cost (\$)
Autoclave	2	Vertical, cylindrical, 125 °C max, Stainless Steel (SS) 316, 6.0 kWh.	1 800
Laminar Flow	1	Vertical, 3.2 kWh.	1 200
Rotary Shaker	1	0.9 kWh, 400 rpm max.	1 500
Hot Air Oven	1	Electrical, 80 °C max, 2.1 kWh.	1 000
pH meter	1	0.06 kWh.	1 100
Refrigerator	1	3 kWh	1 200
Peristaltic Pump	2	Variable speed, 0.25 kWh.	3 000
Microscope	1	0.04 kWh	1 200
Distiller Water Unit	1	Electrical, SS 304, 3.6 kWh, 6 L distilled water/min	15 000
Digital Balance	1	160 kg máx.	2 000
Steam Generator	1	Cylindrical, Fired-tube type, Steam: 4 ton/h, 160 °C, 6 bar	150 000
Seed Fermenter	1	Cylindrical, vertical, automatic, Volume: 75 L, 600 rpm max., 8.0 kWh, SS 316	30 000
Industrial Fermenter	1	Cylindrical, vertical, automatic. Volume: 400 L, 800 rpm max. 14.0 kWh, SS 316	100 000
Disk Stack Centrifuge	1	Clarifier, desludger, 6.8 kWh SS 312, 1080 L/h max.	25 000
Media Preparation Tank (seed fermenter)	1	Vertical, cylindrical, on wheels, SS 309, 50 L, 0.8 kWh	7 000
Media Preparation Tank (industrial fermenter)	1	Vertical, cylindrical, on wheels, SS 309, 350 L, 1.2 kWh	12 000
Harvest Tank	1	Vertical. cylindrical, 3.0 kWh, SS 316, 600 L, with agitation	5 000
Formulation Tank	1	Vertical. cylindrical, 2.0 kWh, SS 302, 600 L, with agitation	6 000
Filling Machine	1	5 units/min, automatic, 0.3 kWh	4 000
Compressor	1	Centrifugal, oil free, 38.2 kWh, Air: 40 Nm ³ /h, 10 bar	150 000
Water Cooling Unit	2	100 kWh each	100 000
Air Handling Unit	4	25 kWh each	80 000
Pumps	4	Centrifugal, 7.5 kWh each, 700 L/h max	6 000
Feed Pump	1	Centrifugal, hygienic type, 400 L/h max, 6.2 kWh	3 000
Air Filter	4	0.2 µm	2 000
TOTAL			709 000

Packing) starts. The industrial fermentation broth is then harvested in a cylindrical, vertical tank equipped with agitation and cooling. The harvested broth is cooled to 10 °C prior to centrifugation, and then is pumped to a clarifying, desludging-type, disk-stack centrifuge for cells (biomass) separation and recovery. The supernatant obtained is sent to the wastewaters treatment section, while the biomass suspension is recovered in another vessel (formulation tank), cooled to 15 °C, and then formulated by adding some formulation substances under agitation conditions. The addition of the formulation substances [sucrose, glycerol, NaH₂PO₄ and (NH₄)₂PO₄] will extend the shelf-life of the liquid inoculant, protect the cell suspension against thermal or pH variations and shocks, as well as improve applicability and performance of the formulated liquid in the field. As said before, the resulting formulation liquid is agitated within the formulation vessel, under 300 rpm for 6 hours approximately, using a paddle-type agitator. Once finished the agitation time, this mixed liquid will be

gradually fed to an automatic filling machine, to be ultimately poured into 1.5 L plastic bottles. The filled bottles should be finally stored at 10 °C.

The plant will have a production capacity of 44 tons of liquid biofertilizer per year, while the volume of liquid biofertilizer to be obtained per batch will be about 590 – 594 L (average of 592 L), The duration time of each production batch will be 109 hours/batch (5 days/batch, approximately), the total required amount of labor needed to operate the biofertilizer production plant, taking into account management staff, supervisors, operators, maintenance crew, office employees, etc., will be of 29 persons. The total amount of production batches required per year to fulfill the production capacity will be 78 batches/year. The plant will be shut down for about 30 days per year in order to carry out usual maintenance operations, equipment adjustment and repairs, thus the annual operating of the plant will be around 7900 hours/year.

Table 2. Main process results (SuperPro Designer®, 2012).

Parameter	Value
Average production rate (1.5 L bottles/yr)	30 810 bottles/yr
Average production rate (1.5 L bottles/batch)	395 bottles/batch
Average production rate (kg/yr)	44 300 kg/yr
Average production rate (kg/batch)	568 kg/batch
Average number of batches per year	78 batches/year
Average batch time	109 h/batch

Raw materials consumption in process stages

Cell propagation

For propagation of *A. brasilense* cell cultures at laboratory scale, the OAB medium was used (Bashan *et al.*, 1993), which is composed of: Solution A [(g/L): DL - malic acid, 5; NaOH, 3; MgSO₄·7H₂O, 0.2; CaCl₂, 0.02; NaCl, 0.1; NH₄Cl, 1; yeast extract, 0.1; FeCl₃, 0.01; (mg/L): NaMoO₄·2H₂O, 2; MnSO₄, 2.1; H₃BO₃, 2.8; Cu (NO₃)₂·3H₂O, 0.04; ZnSO₄·7H₂O, 0.24; 900 mL distilled water] and Solution B [(g/L): K₂HPO₄, 6; KH₂PO₄, 4; 100 mL distilled water]. After autoclaving and cooling, the two solutions are mixed. The pH of the medium pH is 6.8.

Seed culture

The BTB-2 medium was used to carry our seed propagation of *A. brasilense* (Bashan *et al.*, 2011), which contains (g/L): tryptone, 5 (Difco); yeast extract, 5; glycerol, 8 mL/L; NaCl, 1.2; MgSO₄·7H₂O, 0.25; K₂HPO₄, 0.13; CaCl₂, 0.22; K₂SO₄, 0.17; Na₂SO₄, 2.4; NaHCO₃, 0.5; Na₂CO₃, 0.09; Fe(III) EDTA, 0.07. The pH was adjusted to 7.0 after sterilization.

Industrial fermentation

The following culture medium was used for industrial fermentation step (Bashan and de-Bashan, 2015; ICIDCA, 2000) (g/L): Sugarcane molasses, 12; yeast extract, 1; NaHPO₄, 6.0; MgSO₄·7H₂O, 0.25; CaCl₂, 0.22. The pH was adjusted to 7.0 after sterilization.

The use of sugar cane molasses as a raw material to produce liquid biofertilizers, via submerged fermentation processes, has been previously achieved at industrial level and published in the literature (ICIDCA, 2000). Since the biofertilizer production plant will be erected near a sugar factory, the sugarcane molasses will be the main raw material to be consumed in the industrial fermentation stage, since it will be supplied at a constant rate and at low prices by this factory, and also because it constitutes an excellent substrate for the microorganism used which could be stored within the sugar factory

in order to be used at any moment by the biofertilizer plant as convenient.

Liquid formulation

To carry out the liquid formulation of the cells harvested, the following components were used (Taurian *et al.*, 2010; Albareda *et al.*, 2008; Bashan and de-Bashan, 2015; ICIDCA, 2000): sucrose, glycerol, NaH₂PO₄, (NH₄)₂PO₄ and water.

Equipment

Table 2 show the main characteristics and cost of the main equipment used to carry out the production process of liquid biofertilizer (Peters *et al.*, 2003; Sinnott, 2005; Towler and Sinnott, 2008; Perry and Green, 2008).

Utilities

The liquid biofertilizer plant consumes the typical utilities usually used in a facility of this type, that is: cooling and process water, steam, fuel oil, compressed air and electricity, in order to be supplied to the main equipment installed there (fermenters, centrifuges, storage vessels, etc.) and also to the auxiliary devices (instruments, control panels, etc.). The utilities cost (steam, cooling water, process water, distilled water, electricity and labor salary) were estimated according to the market and prices in Cuba in 2016 year, while the utility to be consumed on each piece of equipment is determined by the process simulation model. Process water is included at a cost of \$ 0.24/m³, while the steam is generated in a fired-tube type boiler using fuel oil, and the costs for both fuel oil and steam are based on a fuel oil price of \$ 0.65/L. Electrical costs are estimated at a rate of \$ 0.18/kWh. Cooling water and distilled water costs were fixed at \$ 0.36/m³ and \$ 1.24/m³, respectively. The utilities cost can be easily changed by the user as convenient. Labor costs included \$ 26.00/h for plant operators and \$ 34.00/h for supervisors and managers, while other plant personnel were included at an inclusive cost rate of \$ 18.00/h.

Cost model description

A cost model was developed by using *SuperPro Designer*[®] simulation software, to estimate both capital and production costs for the liquid biofertilizer production process. *SuperPro Designer*[®] possesses an economic evaluator that is specifically developed for bioprocesses, which is very simple and uncomplicated to use. For preliminary techno-economic evaluation and conceptual design of the biofertilizer plant, this economic evaluator was thought to be adequate for the project stage (Intelligen, 2012).

The pricing and cost data were obtained from equipment and raw materials suppliers, technical documents, academic writings, trade organization, government offices and related publications, and all these data were inserted into the cost estimating methodology contained in the *SuperPro Designer*[®] simulator, for results analysis; research and development; profitability and reliability studies; and also to evaluate alternatives. The economic data obtained in an economic model like this is directly related with the raw materials consumption, unit operations number, auxiliary streams and equipment used, labor and services costs. The cost model obtained will aid to characterize and evaluate the main issues that affect the economic reliability and profitability of the biofertilizer production plant, and also will help to assess the impact produced on the costs associated with the liquid biofertilizer industry, when changing some important process aspects such as feedstock

composition and costs, unit operations and equipment number, and also sections addition or removal.

To run properly the cost model contained at the *SuperPro Designer*[®] simulator, an average interest of 7 % was chosen to determine the *Net Present Value* (NPV), with an Inflation Rate value of 2 %, and Income Taxes of 25 %. The lifetime of the project was established in 15 years, with 14 months to construct the plant, while a start-up period of 4 months was selected. The plant will work always at full capacity, and it was assumed a constant depreciation of the equipment involved in the lifetime of the project. It was supposed that there are no costs associated with failed or contaminated product treatment and disposal operations, while the costs related with wastewaters and residuals treatment operations are also not considered in the cost model, since these operations are concerned to other parts. The final selling price of one 1.5 L liquid biofertilizer bottle was fixed in \$ 28.00, this value was selected taking into account Cuban market and prices, because the process conceptual design was established to comply with the Cuban biofertilizer requirements and standards. The buying and selling prices of the products involved in the process have no variations over time; this assumption must be removed in following design step, but for this initial phase of conceptual design, this assumption is suitable. The additional operating costs considered in the cost model include plant maintenance (7% of capital costs); laboratory, quality control and quality assurance (15 %

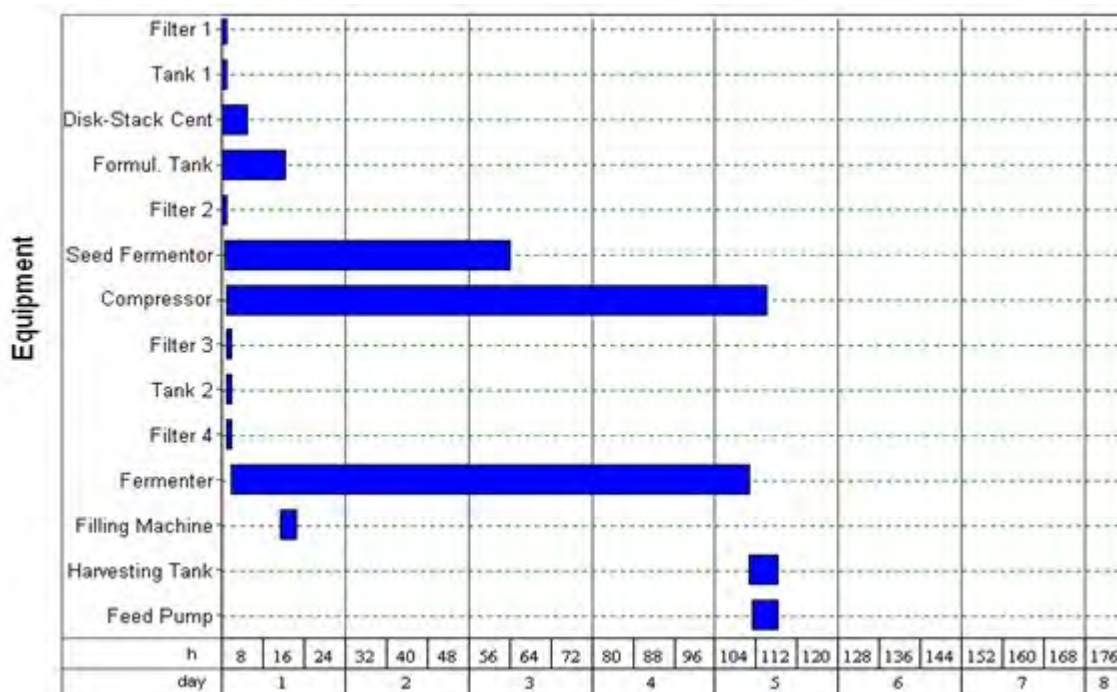

Figure 2. Equipment occupancy chart (*SuperPro Designer*[®], 2012).

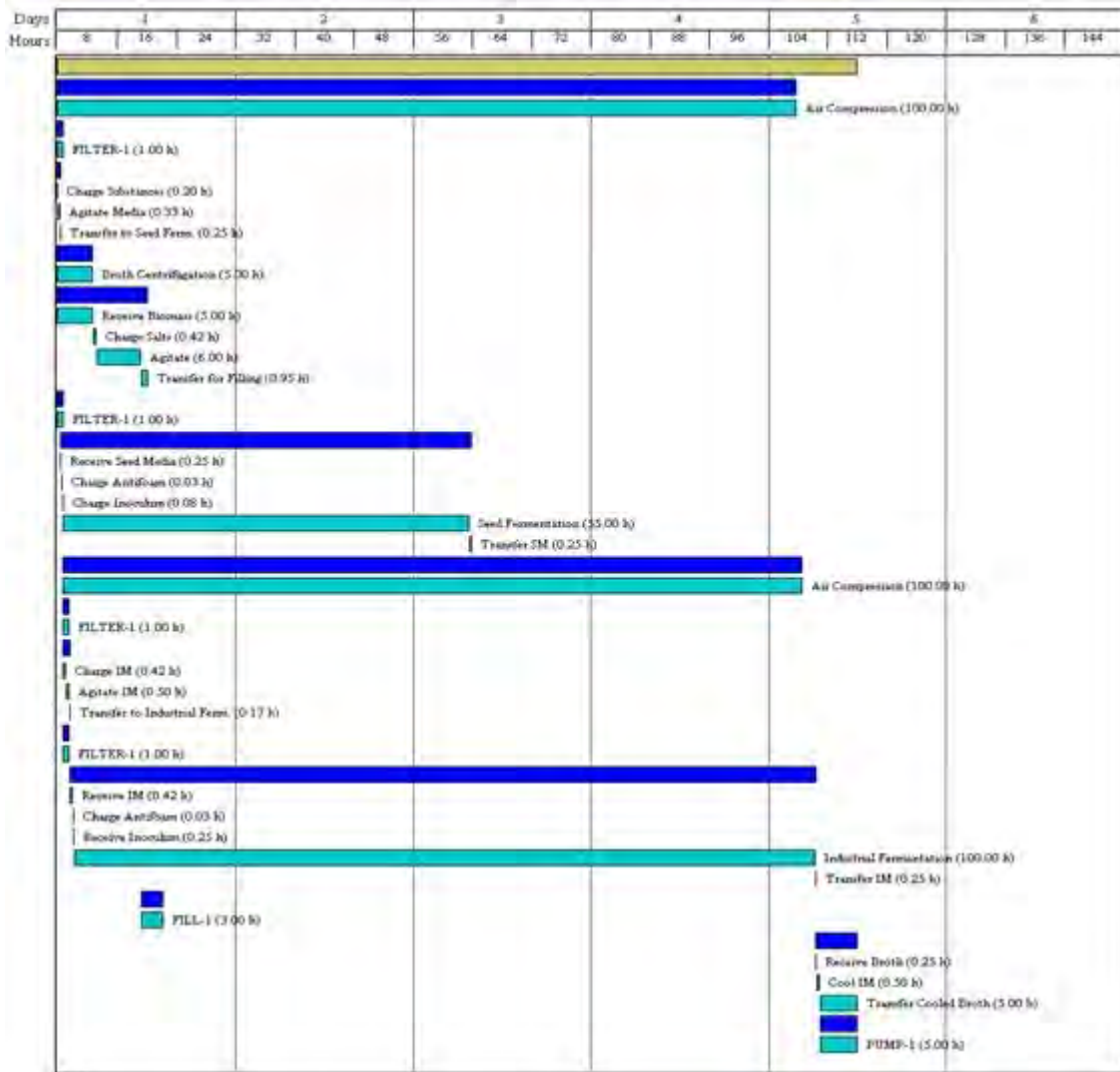

Figure 3. Operations Gantt Chart (SuperPro Designer®, 2012).

of total labor cost); research and development operations (8 % of capital costs); and miscellaneous facility expenses (6% of capital costs). The main economic indicators considered were NPV since it's a financial measurement of the time value of money, and *Internal Rate of Return* (IRR), because it's an indicator of the efficiency of the project.

3D model description

The biofertilizer production plant was designed and optimized by means of the *OptiPlant*® software, based on the flow diagrams and preliminary equipment data, the 3D layout was developed and reviewed within *OptiPlant*® (ASD Global, 2015). The 3D model includes equipment, architectural layout and piping (figure 4). Several arrangement options were modeled and an

optimized arrangement was selected for review. As the project and work progresses, this model can be refined and elaborated to verify and track cost changes.

RESULTS AND DISCUSSIONS

Once obtained both the process and economic models employing process simulation software *SuperPro Designer*®, and also the 3D layout of the liquid biofertilizer production plant using *OptiPlant*® software, a description and analysis of the main process and economic results is performed. Figure 1 shows the simplified *Flow Diagram* of the liquid biofertilizer production plant, while the figure 2 presents the *Equipment Occupancy Chart*. In the figure 3 the *Operations Gantt Chart* is shown.

Table 3. Summary of the fixed capital cost for the project (SuperPro Designer®, 2012).

Item	Value
Total Plant Direct Cost (TPDC)	
Equipment Purchase Cost	\$ 709 000
Installation	\$ 165 000
Process Piping	\$ 390 000
Instrumentation	\$ 142 000
Insulation	\$ 21 000
Electrical	\$ 71 000
Buildings	\$ 106 000
Yard Improvement	\$ 35 000
Auxiliary Facilities	\$ 284 000
<i>TPDC</i>	\$ 1 923 000
Total Plant Indirect Cost (TPIC)	
Engineering	\$ 577 000
Construction	\$ 673 000
Contractor's fee	\$ 159 000
Contingency	\$ 317 000
<i>TPIC</i>	\$ 1 726 000
Direct Fixed Capital Cost (TPDC+TPIC)	\$ 3 649 000

The bottleneck process step is the *Industrial Fermenter* since it's an operation that lasts for about 100 hours, while the equipment that operates the longest time is the *Compressor*, since it's a equipment that supplies compressed, oil-free air for both fermentation processes (seed and industrial), as well as for automatic panels and pneumatic instruments installed in the equipment, thus operating during the entire batch time.

Main process results

Table 3 shows the main process parameters obtained during the simulation study. From the results showed, it will be necessary to carry out about 78 production batches per year producing around 568 kg of liquid biofertilizer per batch, to fulfill the requested production capacity, while the average amount of 1.5 L bottles to obtain per batch and year will be 395 and 30 810, respectively.

Economic results

The fixed capital cost required to build up the biofertilizer plant is summarized in the table 4, while the annual operating costs involved in the production process are showed in table 5. As it can be seen from the table 4, the main items that affect Total Plant Direct Cost (TPDC) are "*Equipment Purchase*" and "*Pi-ping*", while the "*Construction*" and "*Engineering*" are the main items that

influence on Total Plant Indirect Cost (TPIC) value. The total direct capital cost obtained is about \$ 3 700 000.

From the results showed in table 5, the "*Labor-Dependent*" item (that is, salary cost) presents the major influence on the annual operating costs, with 51.85% of the total cost. This is because it's a production process which needs to use, at least, 5 people per 24 hours shift, including operators, supervisors, maintenance and quality control personnel, as well as office and utilities staff. Considering that, it constitutes a labor-intensive industry that requires a relatively high amount of skilled personnel to run properly the plant, and this aspect affects directly the operating costs of the plant. The item "*Miscellaneous and Consumables*", which represents the consumption of items such as gloves, laboratory analysis kits, labels, caps, pipette points, etc., is the second in importance, comprising 29.54 % of the total costs. The "*Raw Materials*" item influences very small in the operating costs (4.01 % of the total) because the main substances and chemicals consumed in the process (See table 1) have a relatively low purchasing cost. The molasses, ammonium sulfate and sucrose will be delivered at zero cost by the sugar factory located near the place where the biofertilizer plant will be constructed, while the other raw materials are acquired at moderately low prices. The third item that affects the operating costs is

Table 4. Annual operating costs (SuperPro Designer®, 2012).

Item	Value (\$/yr)	%
Raw Materials	30 000	4.1
Labor-Dependent	383 000	51.8
Facility-Dependent	9 000	1.2
Laboratory/QC/QA	57 000	7.7
Utilities	39 000	5.3
Miscellaneous and Consumables	218 000	29.5
Advertising and Selling	2 000	0.3
Income Taxes	1 000	0.1
TOTAL	\$ 739 000/yr	100%

the “Laboratory/QC/QA”, with 7.78 % of the total, due to the consumption of reactive and utilities needed to carry out quality control tests and other Quality Control (QC)/Quality Assurance (QA) experiments and essays.

Finally, from table 5 the *Total Investment* charged to the project is \$ 2 828 000, the calculated *Unit Production Cost* for a single 1.5 L bottle of liquid, formulated biofertilizer is \$ 24.009, the *Working Capital* assigned to the project is \$ 32 000, the *Total Revenues* to obtain per year is \$ 985 000/year, while the *Net Profit* to be obtained is \$ 422 000. Finally, the *Gross Margin* value is 24.97 %, the *Return on Investment* (ROI) obtained is 14.93 %, the *Payback Time* will be 6.70 years, and the NPV and IRR obtained were \$ 716 000 and 2.55 %, respectively.

Economic indicators

In table 5 the most relevant economic indicators and project rates, as well as the main profitability data, are summarized.

CONCLUSIONS

A techno-economic model was elaborated and developed for a typical liquid biofertilizer production plant with a capacity to produce 44 tons/year of a liquid biofertilizer, using *Azospirillum brasilense* as the active bacteria. This model can be used to analyze, understand and study the main factors and items that affect the liquid biofertilizer production process, in order to optimize plant productivity, profitability and reliability, and also to reduce the main cost issues associated with it. Additionally, the developed model can be used to test alternative processing technologies to evaluate and predict the impact of the changes made.

Table 5. Project economic indicators and profitability data (SuperPro Designer®, 2012).

Indicator	Value
Direct Fixed Capital	\$ 3 650 000
Working Capital	\$ 32 000
Start-up Cost	\$ 292 000
Up-Front Royalties	\$ 1 000
Total Capital Investment	\$ 3 975 000
Investment Charged to this Project	\$ 2 828 000
Total Annual Operating Cost	\$ 739 000/yr
Unit Production Cost	\$ 24.009 /1.5 filled bottles
Total Revenues	\$ 985 000/year
Gross Profit	\$ 246 000
Net Profit	\$ 422 000
Gross Margin	24.97 %
Return on Investment	14.93 %
Payback Time	6.70 years
Internal Rate of Return (after taxes)	2.55 %
Net Present Value (at 7 % interest)	\$ 716 000

From the results obtained during simulation operations regarding economic indicators, the unit production cost of one 1.5 L bottle of liquid biofertilizer is \$ 24.009, the total capital investment required to buildup the plant will be of \$ 3 975 000, the total amount of 1.5 L bottles to obtain per year will be 30 810 bottles/yr, the ROI value obtained is 14.93 %, the project Payback Time is 6.70 years, the total amount of revenues per year will be of \$ 985 000/year, while the NPV and IRR values obtained were \$ 716 000 and 2.55%, respectively. All that results indicate that the liquid biofertilizer project is feasible to implement both from the technical and economical points of view (Peters *et al.*, 2003; Baca, 2010; Towler and Sinnott, 2008), considering the specific characteristics, economic factors, and market conditions of the country, province and place at which it will be located.

The results obtained in this case study demonstrate that through the implementation of simulation and modeling techniques it's possible to study, analyze and improve processes, while it constitutes a valid and powerful tool to quantify process changes and variations, and also to compare alternative process methods. The results obtained will improve ecological, technical and economical evaluations of the application under study, and also will help to focus the research and optimization approaches towards the most promising directions.

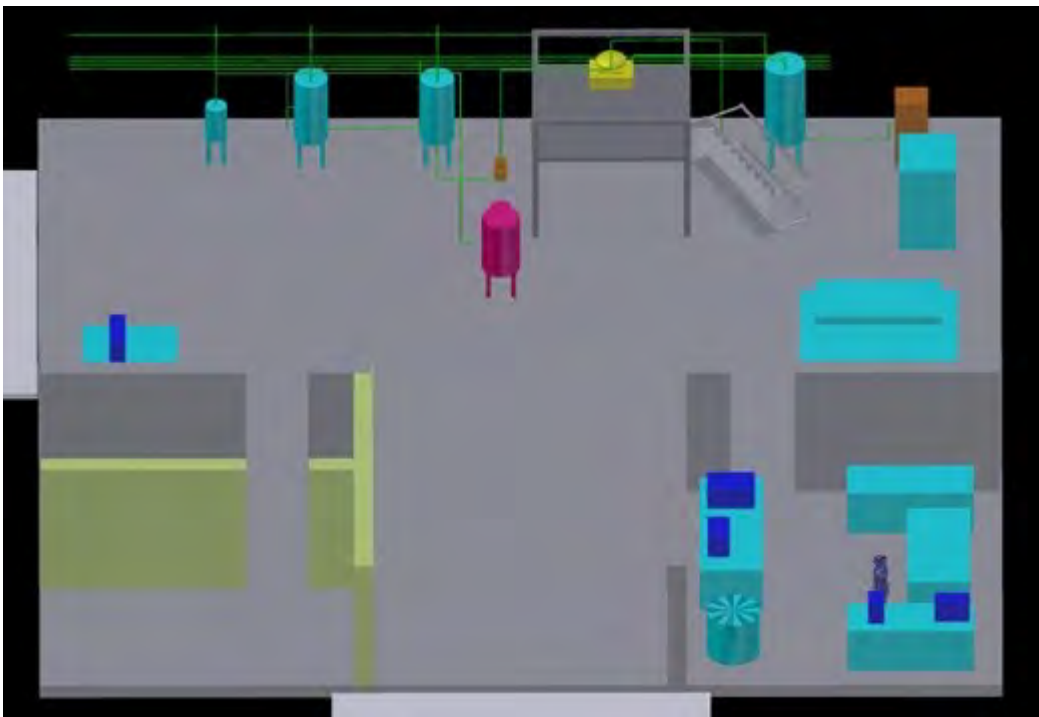
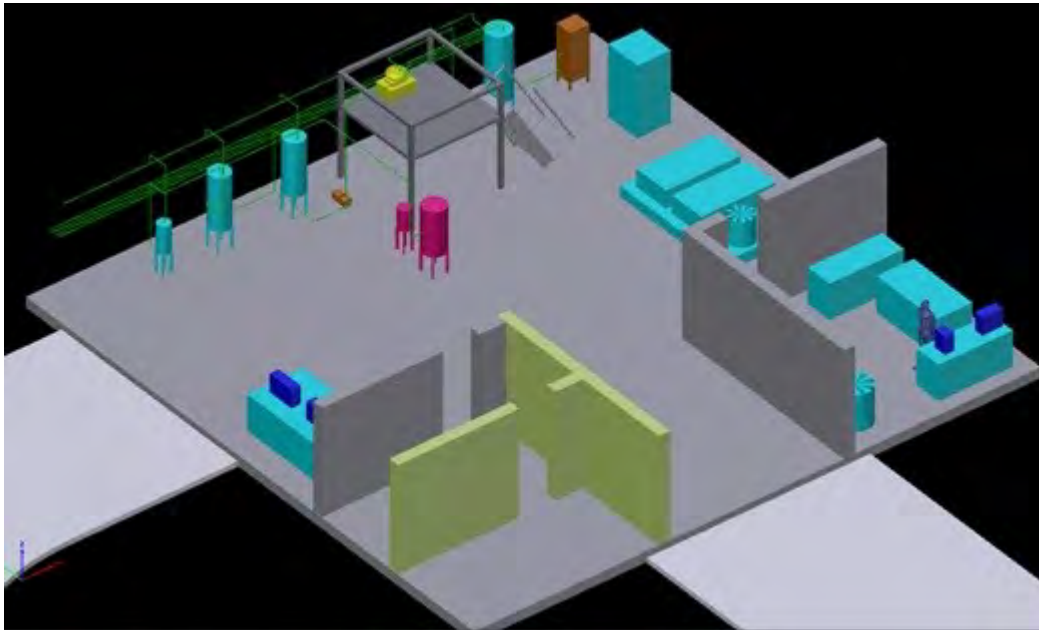

OptiPlant® 3D design layout.

Figure 4. Different 3D layouts obtained for the biofertilizer plant using the OptiPlant® software (ASD Global, 2015).

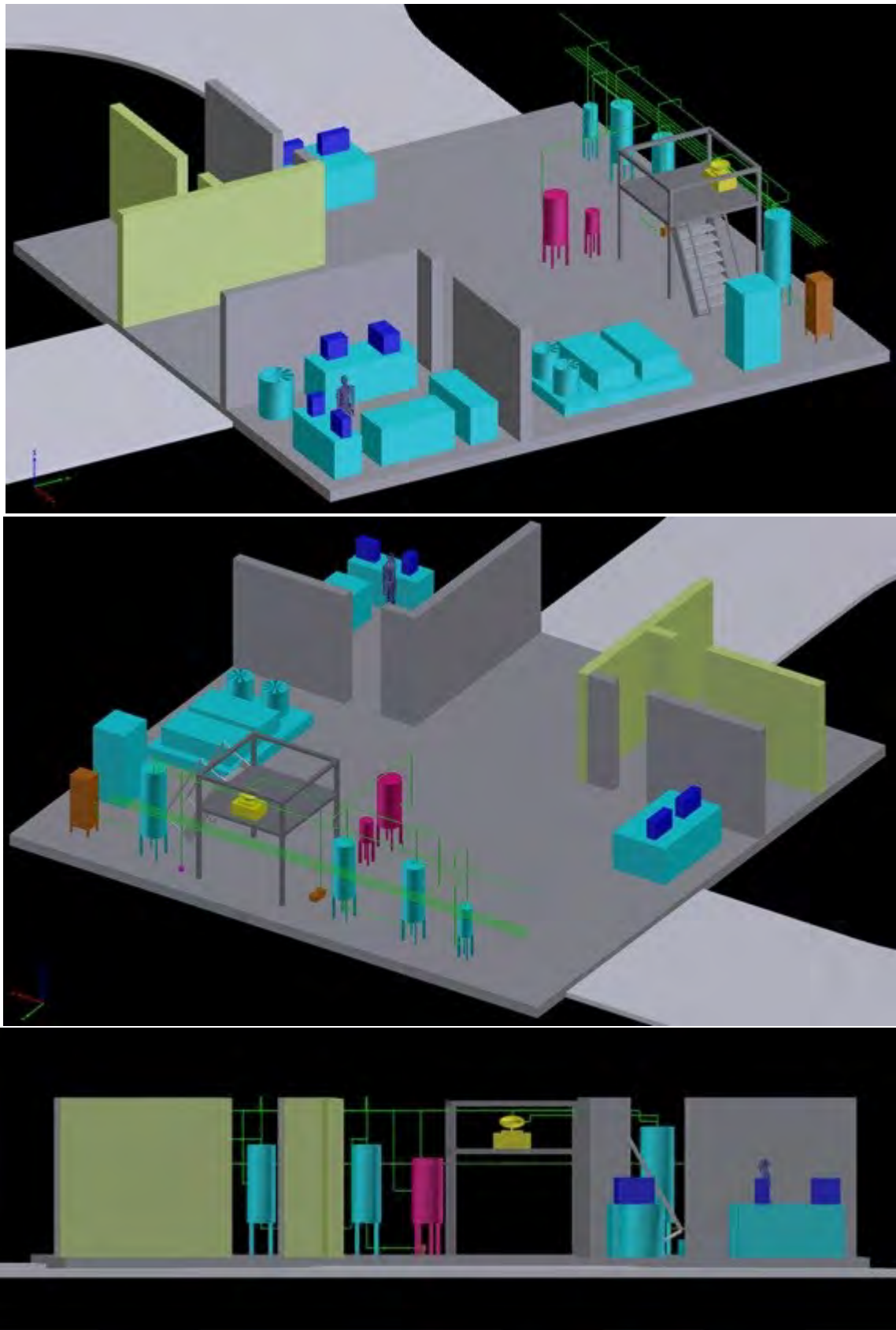

Figure 4. Different 3D views obtained for the biofertilizer plant using the QtoPlant® software (ASD Global, 2015). The model obtained will permit to determine new costs and to create new 2D and 3D drawings and to obtain the 3D model in different locations in the plant.

the base-case equipment costs, labor, feedstock or utilities. The possibility to compare the results obtained in the modified process with those obtained in the base-case will aid researchers and engineers to analyze, develop or assess novel biofertilizer production processes and technologies.

REFERENCES

- Albareda, M., Rodriguez-Navarro, D. N., Camacho, M., & Temprano, F. J. (2008). Alternatives to peat as a carrier for rhizobia inoculant: solid and liquid formulations. *Soil Biol Biochem.*, 40, 2771–2779.
- ASD Global. (2015). OptiPlant® Software. Walnut Creek, United States: ASD Global. (www.OptiPlant.com).
- Baca, G. (2010). *Evaluación de proyectos* (6ta ed.). México, D. F.: McGraw-Hill/Interamericana Editores S.A. DE C.V.
- Baldani, V. L. D., Baldani, J. I. & Döbereiner, J. (1983). Effects of *Azospirillum* inoculation on root infection and nitrogen incorporation in wheat. *Canadian Journal of Microbiology*, 29, 924–929.
- Bashan, Y., Holguin, G. & Lifshitz, R. (1993). Isolation and characterization of plant growth-promoting rhizobacteria. In: Glick B. R., Thompson J. E. (eds) *Methods in Plant Molecular Biology and Biotechnology*, Boca Raton: CRC Press, p. 382.
- Bashan, Y., Trejo, A. & de-Bashan, L. E. (2011). Development of two culture media for mass cultivation of *Azospirillum* spp. and for production of inoculants to enhance plant growth. *Biol Fertil Soils*, 47, 963–969.
- Bashan, Y. & de-Bashan, L. E. (2015). Inoculant Preparation and Formulations for *Azospirillum* spp. In: Cassán F. D. et al., (eds.) *Handbook for Azospirillum: Technical Issues and Protocols*. Switzerland: Springer International Publishing, p. 515.
- Biwier, A. & Heinzle, E. (2004). Process modeling and simulation can guide process development: case study α -cyclodextrin. *Enzyme and Microbial Technology*, 34, 642–650.
- Dimian, A. C., & Bildea, C. S. (2008). *Chemical Process Design: Computer-Aided Case Studies*. Germany, Weinheim: WILEY-VCH Verlag GmbH and Co. KGaA, p 529.
- Ernst, S., Garro, O. A., Winkler, S., Venkataraman, G., Langer, R., Cooney, C. L. & Sasisekharan, R. (1997). Process Simulation for Recombinant Protein Production: Cost Estimation and Sensitivity Analysis for Heparinase I Expressed in *Escherichia coli*. *Biotechnol. Bioeng.*, 53, 575–582.
- Fages, J. (1992). An industrial view of *Azospirillum* inoculants: production and application in technology can stimulate plants. *Symbiosis*, 13, 15–26.
- Farid, S. S. (2007). Process economics of industrial monoclonal antibody manufacture. *Journal of Chromatography B.*, 848, 8–18.
- Gódia, F. & López J. (1989). Ingeniería Bioquímica. Editorial Síntesis, Madrid, p. 350.
- ICIDCA. (2000). *Manual de los Derivados de la Caña de Azúcar*. La Habana, Cuba: Instituto Cubano de Investigaciones de los Derivados de la Caña de Azúcar, p 421.
- Intelligen. (2012). SuperPro Designer® (Version 8.5). Scotch Plains, United States: Intelligen Inc. (www.intelligen.com)
- Krajnc, D., Mele, M. & Glavič, P. (2007). Improving the economic and environmental performances of the beet sugar industry in Slovenia: increasing fuel efficiency and using by-products for ethanol. *Journal of Cleaner Production*, 15, 1240-1252.
- Kwiatkowski, J. R., McAloon, A. J., Taylor, F. & Johnston, D. B. (2006). Modeling the process and costs of fuel ethanol production by the corn dry-grind process. *Industrial Crops and Products*, 23, 288–296.
- Marchetti, J. M., Miguel, V. U. & Errazu, A. F. (2008). Techno-economic study of different alternatives for biodiesel production. *Fuel Processing Technology*, 89, 740-748.
- Mishra, B. K. & Dadhich, S. K. (2010). Methodology of nitrogen biofertilizer production. *J. Adv. Dev. Res.*, 1 (1), 3-6.
- Okon, Y. & Vanderleyden, J. (1985). *Azospirillum* as a potential inoculant for agriculture. *Trends in Biotechnology*, 3, 223–228.
- Perry, R. H. & Green, D. W. (2008). *Chemical Engineers' Handbook*, 8th Ed. New York: McGraw Hill Inc. p. 2 655.

- Peters, M., Timmerhaus, K. & West, R.. (2003). *Plant Design and Economics for Chemical Engineers*. New York: McGraw-Hill. p. 988.
- Prabavathy, V. R. Rengalakshmi, R. & Nair, S. (2007). *Decentralised Production of Biofertilisers – Azospirillum and Phosphobacteria*. Chennai, India: JRD Tata Ecotechnology Centre, p. 36.
- Ramírez, E. C., Johnston, D. B., McAloon, A. J., Yee, W. & Singh, V. (2008). Engineering process and cost model for a conventional corn wet milling facility. *Industrial Crops and Products*, 27, 91-97.
- Roldán, M., Valdez, N., Monterrubio, C., Sánchez, E., Salinas, C., Cabrera, R., Gamboa, R., Marin Palacio, L., Villegas, J. & Cabrera, A. B. (2013). Scale-up from shake flasks to pilot-scale production of the plant growth-promoting bacterium *Azospirillum brasilense* for preparing a liquid inoculant formulation. *Appl. Microbiol. Biotechnol.*, 97 (22), 9665-9674.
- Rouf, S. A., Douglas, P. L., Moo-Young, M. & Scharer, J. M. (2001). Computer simulation for large scale bio-process design. *Biochemical Engineering Journal*, 8, 229-234.
- Sinnot, R. K. (2005). *Coulson & Richardson's Chemical Engineering: Chemical Engineering Design*, Vol. 6, 4th. Ed. Oxford: Elsevier Butterworth-Heinemann. p. 1055.
- Spaepen, S, Van Derleyden, J. & Okon, Y. (2009). Plant growth-promoting actions of rhizobacteria. *Adv. Bot. Res.*, 51, 283–320.
- Taurian, T., Anzuay, M. S., Angelini, J. G., Tonelli, M. L., Ludueña, L., Pena, D., ... & Fabra, A. (2010). Phosphate-solubilizing peanut associated bacteria: screening for plant growth-promoting activities. *Plant and Soil*, 329 (1-2), 421-431..
- Tien, T. M., Gaskins, M. H. & Hubbell, D. H. (1979). Plant growth substances produced by *Azospirillum brasilense* and their Effect on the growth of Pearl Millet (*Pennisetum americanum* L.). *Applied and Environmental Microbiology*, 37 (5), 1016-1024.
- Towler, G., & Sinnott, R. (2008). *Chemical Engineering Design-Principles, Practice and Economics of Plant and Process Design*. London: Butterworth-Heinemann, p. 1266.