

STATE OF KNOWLEDGE IN LEVEL OF IMPLEMENTATION: PRINCIPLES OF MEASUREMENT ESTADO DE CONOCIMIENTO EN INSTRUMENTACIÓN DE NIVEL: PRINCIPIOS DE MEDICIÓN

Andrés Escobar Díaz,¹ Nubia Marcela Rodríguez Figueroa,² Alejandro Hurtado Beltrán³

Abstract: This article presents a review of the principles of level measurements in liquids and solids that can be found in the industrial scope. First, one has to realize a classification of consulted sources, presenting the area of research to which each one belongs to. Later the key definitions are shown in level instrumentation measurement systems, indicating instrument, intelligent sensor and transmitter: Then it is shown what the measurement point level and continuous level measurements are, there are two ways of measuring, well differentiated levels, which govern the operation of a meter. Subsequently, the measuring principle of each meter levels are shown as: basic parts, the operating principle, and in some cases the physical-mathematical model representing the behavior of the meter. Finally, the conclusions of the work are critically exposing the obtained reviews so that it serves as a guiding method for expanding research as new developments or innovations appear in the matter.

Keywords: Industrial instrumentation, level measurement, hydrostatic pressure, gauges, intelligent transmitter.

Resumen: En este artículo se realiza una revisión de los principios de medición de nivel de líquidos y sólidos que pueden llegarse a encontrar en el ámbito industrial. En primer lugar, se realiza una clasificación de las fuentes consultadas, dando a conocer el área de investigación a la que pertenece cada una. Seguidamente se muestran las definiciones clave en la instrumentación de nivel: sistema de medición, instrumento indicador, sensor y transmisor inteligente. Luego se da a conocer en qué consiste la medición de nivel de punto y la medición de nivel continua dos formas de medición de niveles bien diferenciadas, las cuales rigen el funcionamiento de un medidor. Posteriormente se describe el principio de medición de cada uno de los medidores de nivel, dando a conocer: partes básicas, el principio de

1 Universidad Distrital Francisco José de Caldas, Bogotá, Colombia. E-mail: aescobard@udistrital.edu.co

2 Universidad Distrital Francisco José de Caldas, Bogotá, Colombia. E-mail: nmrodriguez@correo.udistrital.edu.co

3 Universidad Distrital Francisco José de Caldas, Bogotá, Colombia. e-mail: ahurtadob@correo.udistrital.edu.co

funcionamiento, y en algunos casos el modelo físico-matemático que representa el comportamiento del medidor. Finalmente, se muestran las conclusiones del trabajo, exponiendo críticamente la revisión obtenida de modo que sirva como método orientador para ampliar la investigación realizada a medida que aparezcan nuevos desarrollos o innovaciones en la materia.

Palabras clave: instrumentación industrial, medición de nivel, medidores, presión hidrostática, transmisor inteligente.

1. Introduction

This article arises as a need for a framework of knowledge, initial and comprehensive research projects for automation, instrumentation and control level. This has a compilation of the principles of operation indicators, switches, transmitters and system level measurement is performed. Its purpose is focused on promoting future work which depends in aspects such as criteria level meter selection, application sectors and industries, and manufacturing processes involved to guide innovations and developments in the area. The level, as well as other variables must be monitored correctly for each of the processes in different industries so it can be carried out with complete satisfaction and without the risk of affecting the safety and operation of the plant.

This is the way that manufacturers have developed solutions that are tailored to the industries, and are expressed with a certain measure that are in the ability to communicate with other parts of the process, perform self-calibration, and even alert when maintenance or repair is required. However, not all meters are optimal in each of the applications. It should be taken into account a number of factors that can affect the measurement result. These factors are: the temperature, the pressure, the type of product required to measure product properties, the amount of product, and the container shape among others. Therefore, it is important to know the different operating principles of the leveled meters and the physical phenomena that are present, therefore avoiding the inconveniences that may arise due to the limited information updated in the issue. The document structure is as follows. From the third section it describes the types of meters available for detecting any variable. Then, in the fourth section, the two forms have shown in which an instrument gives the levels of a container. Finally, in the fifth section, it is disclosed that each of the operating principles of the

A Current Vision

level meters, carrying out a review and differentiation between those who take advantage of the exerted pressure by the liquid at the bottom of the tank (hydrostatic pressure), will take an advantage to the electrical properties of the liquid, as well as those who perform direct measurements and finally those who perform, by other means the measuring principles.

2. Materials and methods

The systems, indicators, switches and level transmitters exposed here are of industrial design, in such a way that a review of the information is carried in the first instance, and from the last decade journals that are related to an industrial level. Particularly, Control Engineering presents a broad overview on some principles of level measurement, as well as developments in this field in terms of communication protocols, applied software, self-diagnostics and self-calibration. It also, goes to the prepared search by manufacturers such as: *Vega, Endress+Hauser, Magnetrol, Rosemount, ABB*. Such articles describe in detail the features of its products, and the benefits that can occur in certain industrial applications. Similarly, manufacturers' websites where details on the measurement principles appear documented the industries application, the measurement products, the communication protocols, and the advantages and disadvantages of meters among others. To further the information on case studies about the performance of the level meters in real industrial applications magazines are consulted as: *Control, Intech and Plan Engineering*.

It is worth mentioning that [1]. It forms the basis for the review of existing types of industrial level gauges. However, because in the study period an absence of recent information was identified, we turned to a literature available in [2], [3], [4] y [5]. The classification of the themes and sources used in this article can be seen in Table 1, and were endorsed by the research group ORCA¹.

Knowledge Aspects	Aspects to Revise	Information Sources
Principles of Measurement of	Industrial Scale Level Meters	[1], [6], [7], [8], [9], [10-14],

¹ Research Group ORCA: Orden y Caos. Ranking C of Colciencias, Colombia. Universidad Distrital Francisco José de Caldas.

A Current Vision

existing levels in the Industry	Principle of Operation of each level measurer	[15], [16], [17-18], [19-21], [22-30], [31-37], [38-39], [40-42].
	Indicator Description, Interrupter, Transmitter or Measuring System	
Characteristics of each one of the beginning levels of measurement	Implied Elements in the functioning and parts of the interrupter, transmitter, indicator or the level measuring system	[10], [11], [12], [22], [23], [25], [26], [27], [28], [31], [32], [38], [45], [46], [47], [49], [50], [53], [55], [57].
	Factors that influence in a positive or negative way the level measuring working systems order	
	Physical or Mechanical Properties of the Level Measurer	
Description of the Elements or the Measuring Systems	Differences between the transmitter, interrupter, indicator and the Measuring system	[13], [14], [15], [16], [17], [18], [19].

	Definitions between Intelligent Transmitters	
	Basic Components of an Intelligent Level	

Table 1. Classification of themes and source selection. **Source:** Own.

3. Types of Measurers

3.1 Measuring System

A measurement system is a set of elements capable of converting a physical variable in a signal or indication [14]. In the level measurement, for example, the level measuring system is found bubbling, in which you can find a series of elements such as flow meter, flow regulator, pressure gauge and a dip tube which are working together to determine the hydrostatic pressure of the liquid in the container and likewise disclose that level.

3.2 Indicating Instruments

Instruments indicators are composed generally of a set scale in which the variable can be the quantified measurement and also from an indicator that discloses the measurement [15]. Magnetic level indicators are a clear example of this measuring instrument because, as it will be seen later, an increase in the level of the container occurs, a visual indication of the level is produced from a scale ranging from the lowest to the highest level.

3.3 Sensor

The sensor is an electronic device that receives information from an external variable and transforms it into another type of magnitude that can be quantified and then used. The sensors are capable to measure variables such as temperature, level, pressure, distance, speed, among others [16], [17]. In the case of the level measurement, as will be seen below, the sensor can be part of an active form of a transmitter or simply not a level transmitter [15].

3.4 Intelligent Transmitter

The smart transmitters, in addition to measuring and transmitting the measured data [18] are in the ability to perform functions such as: measurement error correction, self-adjustment, auto diagnosis and configuration online. The correction for measured errors consists in filtering noise that may occur, as well as monitoring and compensating the internal and external factors that may potentially affect the measurement result.

The Auto-tuning consists in the "auto configuration" parameters such as linearity and temperature so that the output signals adjust to the expected results. On the other hand, self-diagnosis is the monitoring internal and external parameters of the transmitter which can affect normal operation. In the online re-configuration, modification is done among other functions, data acquisition, band frequency and power consumption. This is depending on the diagnostic information and different phenomena that may occur [19].

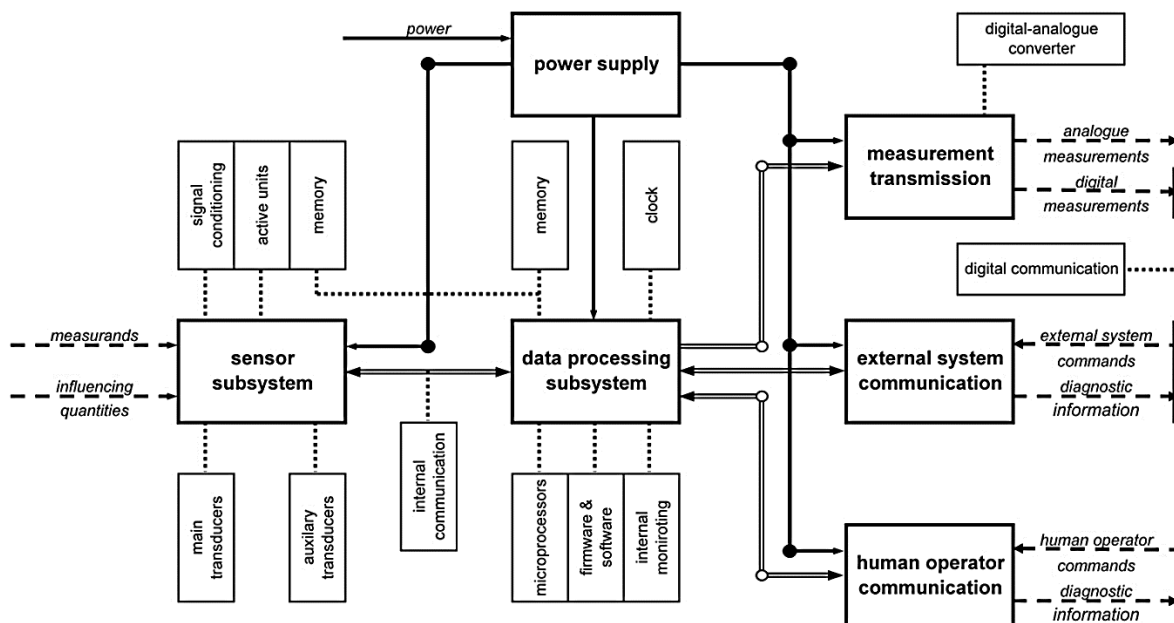

Figure 1. Schematic of operation of a smart transmitter. **Source:** [19], [20].

The operating parameters of a smart transmitter, Figure 1, are as follows [19]:

- The sensor, primary part of the transmitter, can be the main part or auxiliary. The main sensor is responsible for taking the variable process and converts it into an electrical signal. While the auxiliary sensor monitors variable influences: temperature, pressure, among others.
- Data processing is the intelligent part of the transmitter and it is there where all the information obtained by the sensors is handled, making known of the requested data reliably and accurately.
- Communication systems in a transmitter are vital in operation and performance. The transmission of measurement data can be performed in an analogous manner (digital or analog digital). Likewise, diagnostic information can be transmitted to transmitter human operators or other types of systems; this is of course since some processes depend on the reliability of the transmitter's measurement.
- The transmitters power can be carried out by an external source like a battery or simply while the communication signal is being transmitted.

This is how the smart transmitter while linking different systems, is able to exert coordination of both monitoring and control system using different communication protocols offered by different manufacturers. Additionally, it achieves compensation of external factors that may affect significantly the measurement, in such a way that the measurement process is carried out with the least amount of setbacks and delivering to the operator or the control system, accurate and reliable data.

4. Continuous level measurement and point level measurement

The level meters may or may not perform continuous measurement. When level measurement is carried out continuously, the meter monitors the level in the whole extension of the container. That is to say that it is in the ability to indicate exactly which is the height of the product (liquid or solid) in a container. When level measurement is not carried out continuously, it is called point level measurement, and it consists in the level detection in certain parts of the tank. The point level measurement is used, for example, to activate an alarm, either by overflowing or being at a very low level of a particular product into a container [21]. The level meters that perform this type of measurement are often called switches or level detectors.

5. Level Meters

The level meters that can be found at an industrial level, can be: measurement systems, indicators, switches or transmitters. This depends on the features and applications that such meter could have. Table 2 shows each of the measurement principles to be discussed in this article, as well as its main features.

5.1. Level meters based on the hydrostatic pressure

Hydrostatic pressure is the pressure that can come to exert a liquid at the bottom of a container. This pressure depends on the gravity speed g , of liquid density ρ and liquid height h on the container base. Therefore, the hydrostatic pressure P is given by (1).

$$P = \rho * g * h \quad (1)$$

Below you will see the operation of the bubbling level meter and level meter differential pressure, which act on the principle of measuring hydrostatic pressure.

5.1.1. Bubble level meter

The bubbling level meter, (figure 2) is a measuring system that has a narrow dip tube in which a liquid or gas is injected under constant pressure. The pressure exerted by the liquid or gas in the dip tube, must be greater than the hydrostatic pressure generated by the liquid and it needs to measure enough liquid to displace it and generate bubbling, and measured by a manometer or a pressure transducer. At the top, the dip tube has a rota meter and a flow regulator which ensures the intake of the liquid or gas constantly. Once it is known the pressure in the pipe and the density of the liquid, it is possible to determine the level [1], [22], [23]. The level can be calculated by (2).

$$h = \frac{P}{\rho * g} \quad (2)$$

In which (2), P is the pressure exerted by the liquid, h is the height of liquid in the container, ρ is the density of the liquid and g is the acceleration due to gravity, that is to say that 9.8 m/s^2 .

A Current Vision

Measure Principle	Is It In Contact With The Measuring Product?	Does it Measure Liquids?	Does it Measure Solids?	Does it Measure Interfaces?	Does it Make Continuous Level of Measurement?	Does it Measure Point Level?
Bubbling	Yes	Yes	No	No	Yes	No
Differential Pressure	Yes	Yes	No	No	Yes	No
Radar with guided wave	Yes	Yes	Yes	Yes	Yes	No
Radar without Contact	No	Yes	Yes	No	Yes	No
Ultrasonic	No	Yes	Yes	No	Yes	No
Capacitive	Yes	Yes	Yes	No	Yes	Yes
Radioactive	No	Yes	Yes	No	Yes	Yes
Magnetic Level Indicator	Yes	Yes	No	Yes	Yes	No
Magnetostrictive	Yes	Yes	No	Yes	Yes	No
Laser	No	Yes	Yes	No	Yes	No

Table 2. Different measurement principles that will be discussed in the article.

Source: Own .

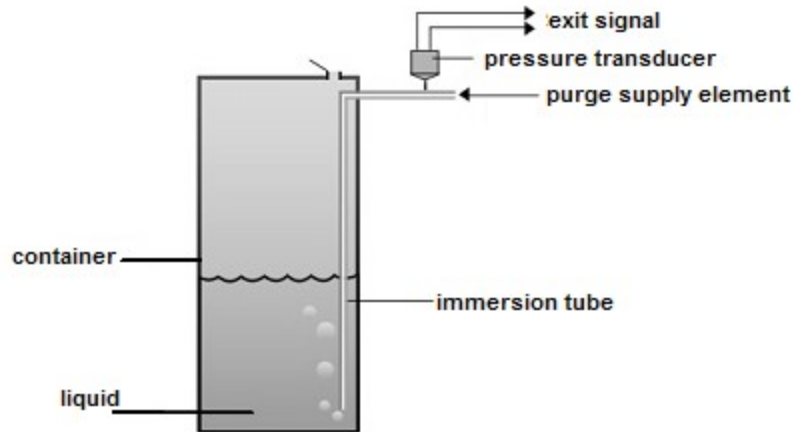

Figure 2. System bubbling level measurement. [24].

5.1.2. Level Meter differential pressure

The level meter is a differential pressure transmitter that can be used in open or closed containers. When the container is open, Figure 3, also known as atmospheric pressure, the level meter differential pressure only takes the reading to the pressure exerted by the liquid column at the bottom of the container. The pressure is measured by a diaphragm seal that is in contact with the measuring liquid. A diaphragm is a pressure transducer having a membrane². When the liquid pressure exerts a force on the membrane, a transducer discloses the pressure applied thereon. The diaphragm seal is connected to the container by a flange, which can be flush or ground type. The level meter differential pressure calculates the level of the open container, by (2) [1], [23].

2 Thin films of elastic and durable material.

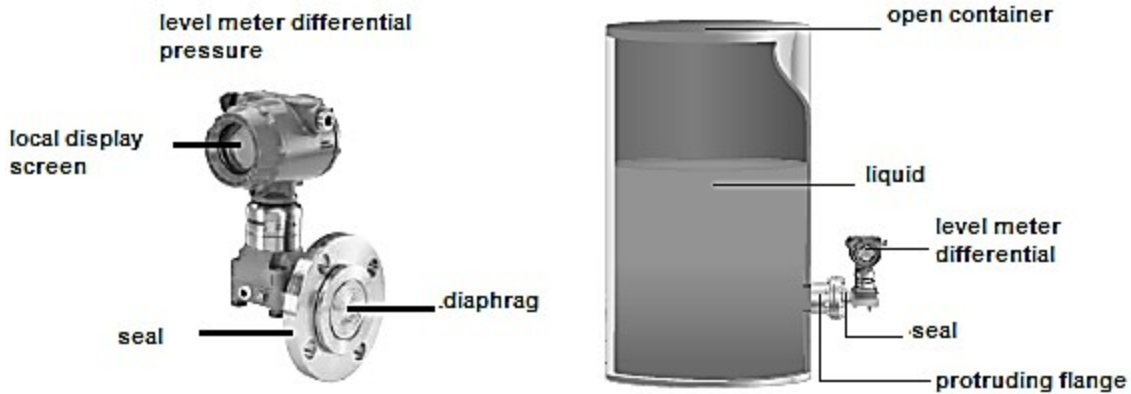

Figure 3. Level Meter differential pressure in an open container. **Source:** [25].

When the container is closed, Figure 4, the level meter performs the differential measurement of two pressures:

On the top of the container it takes the low pressure, and on the bottom of the container it takes the high pressure. The meter calculates the level in the container during the two different pressure measures [26] [27].

Then, the difference resulting from the hydrostatic pressures measured Δp its equal to the density of the liquid ρ multiplied by the height of the container h and to the acceleration due to gravity g . Therefore, the height of the liquid in the container can be calculated by (3) [28].

$$h = \frac{\Delta p}{\rho * g} \quad (3).$$



Figure 4. Level Meter electronic differential pressure in a closed container. **Source:** [25], [27]

A Current Vision

Level measurement in closed containers by differential pressure can be accomplished in two ways. The first consists in connecting a capillary tube. In one of its ends, it is attached to a diaphragm seal and at the other end to the meter. This connection is made in both the high pressure side and the low pressure side. The capillary tube is made of metal and contains oil inside. The oil transports the pressure that is made from the liquid to the meter. The pressure taken by the diaphragms is transmitted to the oil of the capillary and then to a piezoelectric sensor located on the meter. The capillary pressure measurement fails if these are exposed to high temperatures, since the density of oil present inside the capillaries may vary, generating wrong pressure data to the meter [1], [26], [29]. The second way consists in the use of electronic pressure sensors, Figure 4, the pressure signal sent to the meter via cables. The location of the electronic differential pressure gauge is also in the ability to measure temperature and static pressure, so that the liquid density does not affect the measurement result. Compared with the measurement system via capillaries, this system has not shown drawbacks from the influence of different temperatures, achieving a more reliable and accurate measurement [30].

5.2. Radar or Microwave Level Meter

The radar or microwave level meter is an ideal transmitter to measure levels of fuel or chemicals. This measuring principle is sensitive to variation of atmospheric conditions and it does not affect its accuracy, It requires little maintenance and does not contaminate the measurement product. In addition, it is in the ability to record any obstacle in the tank so that the reading is adequate. Transmission of the radar signal is immune to changes in temperature or pressure [31], [32], [23]. The radar level meter can perform measurement using two methods: free or contactless space, and by gavage, also called guided wave radar.

5.2.1. Level Meter guided wave radar

The level meter guided wave radar, Figure 5 is a transmitter that has a probe (which it is in contact with the product) whereby electromagnetic pulses are sent to a frequency of about 1.2GHz (the frequency depends on the manufacturer). Some of the energy that is sent in pulse returns when it reaches the surface of the product, or when it finds a dielectric discontinuity. Subsequently, the meter calculates the level (taking the travel time of the wave) by reflectometry technique in the time domain.

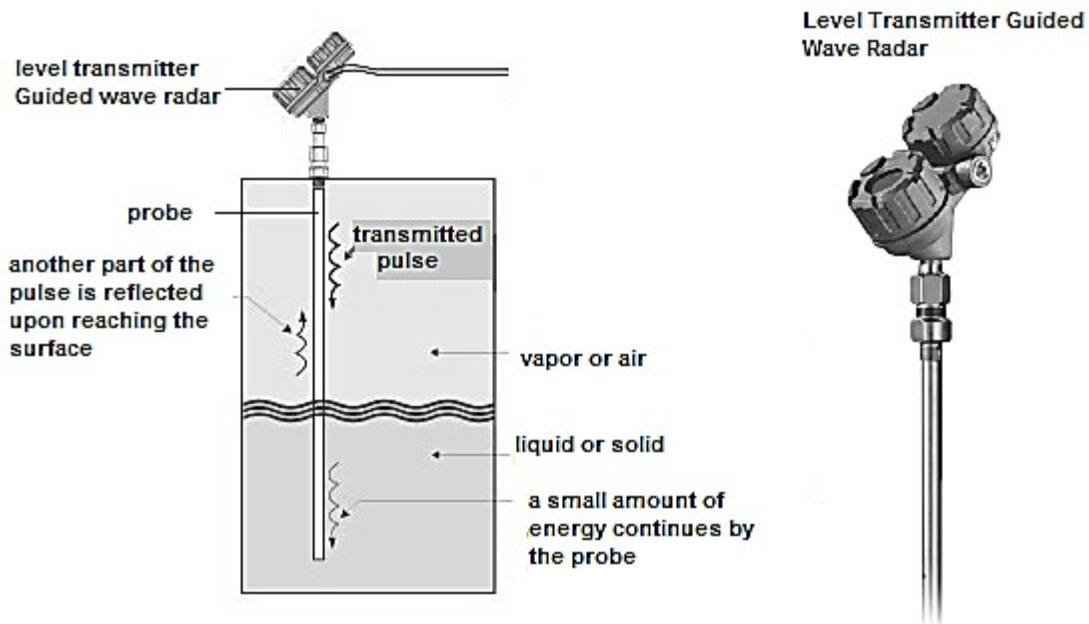

Figure 5. Level Meter guided wave radar. **Source:** [33], [34].

The technique of reflectometry in the time domain is sending pulses of electromagnetic energy which when it collides with the liquid surface and detects a change in the dielectric constant, it will return to its place of origin. The higher the dielectric constant of the product is, the greater the amount of energy reflected [33], [35], [36], [37].

The probe having the meter guided wave radar ensures that there is no present degradation and it reaches where the level of the liquid or solid really is [1]. To learn more about how the meter guided wave radar, is recommended see [38].

5.2.2. Level meter for no contact radar

The level meter for contactless radar (Figure 6) is a transmitter that calculates the level using two techniques: "Continuously modulated high frequency wave" (OCMAF) and "Return Time" (TR). In the OCMAF technique, the meter continuously sends an electromagnetic wave towards the surface of liquid or solid from the top of the container and at a standard frequency of 10 GHz. Upon reaching the surface of liquid or solid, one part of the wave is reflected shifting frequencies and returning back to the meter. The electronics of the Meter records the

time that the signal is sent and that the signal is reflected (detecting in it the frequency change) and a microprocessor then calculates the level by (4), [37], [22], [1].

$$h = H - \left(\frac{v * \Delta t}{2} \right), \text{ where } v = \frac{c}{\sqrt{\epsilon}} \quad (4)$$

In (4) H is the complete height of the container, h is the height of the product in the container, v is the speed of the signal, Δt is the signals time of travel, c is the speed of light, and ϵ is the constant dielectric of the product.

On the other hand, the TR technology, contactless radar level meter consists in sending a magnetic pulse from the meter to the liquid surface in a range of frequencies between 1 y 100 GHz. The pulse travels until a change in impedance to generate its return; for the meter to perform the calculation of the level, it takes as its main data the travel time of the pulse. Figure 6.

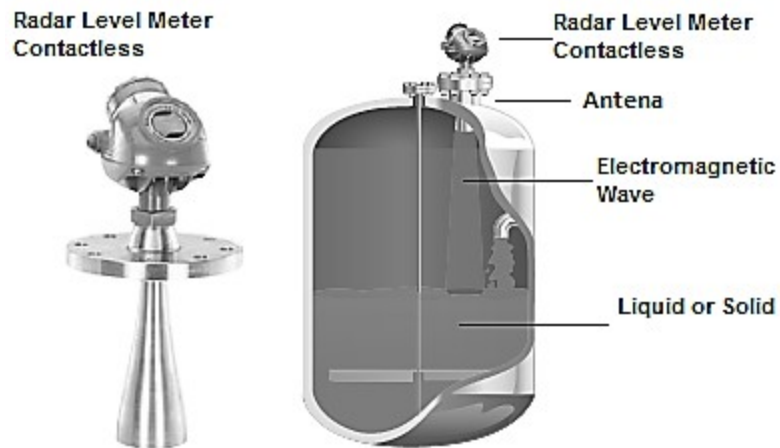

Figure 6. Radar level meter without contact. **Source:** [25].

The contactless radar level meter can present degradation of the wave in the atmosphere Tank, but it works well in environments with high temperatures, high pressures, and even empty [37], [28]. In [39] it can be seen the mounting of the meter radar without contact, as the functionality of compensation of the meter in liquid with foam applications.

$$h = \frac{v_p * t}{2} \quad (5)$$

5.3. Ultrasonic level meter

In continuous level measurement, the level meter ultrasound (ultra sonic transmitter) it may be located both at the top and bottom of the container. When the meter is located at the bottom of the container, it generates an electrical impulse which is converted by a transducer (piezoelectric crystal) in an ultrasonic impulse. The ultrasonic pulse travels through the tank walls until it reaches the surface of the product. Once the ultrasonic pulse reaches the surface of the product, it returns to the meter and it then calculates the product height in the container, which is given by (6) [1].

$$h = \frac{V_s * t}{2} \quad (6).$$

So that in (6), h is the height of the product in the container, V_s is the velocity of sound, and t is the time of sound travel.

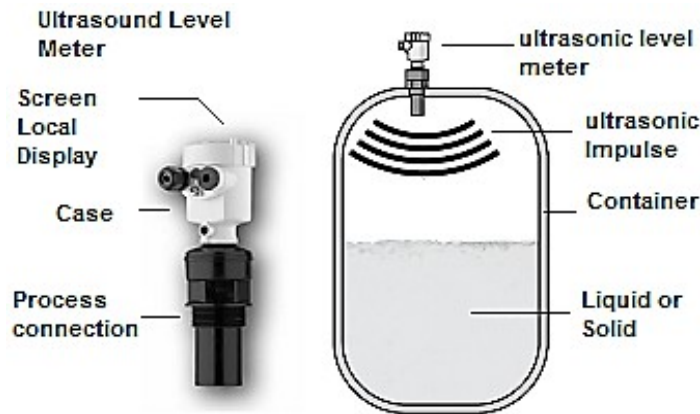

Figure 7. Level Meter ultrasound [40].

When the ultrasonic level meter is located at the top of the container (Figure 7) it generates an ultrasonic pulse in a frequency range ranging from 10 kHz to 70 kHz traveling through the air and returning to the liquid surface. The meter has a microprocessor that calculates the travel time of the generated ultrasonic pulse and determines the level in the container [1], [41], [42]. So that the ultrasonics level meter make a good measurement is preferable that the surface is flat and perpendicular to the sound wave or the meter remains

located in such a way that there is no obstructions to the ultrasonic pulse present [43], [44]. In [45], it can be observed in detail the measuring principle of ultrasound and other technologies that perform the calculation of the level by fly back signal.

5.4. Capacitive level meter

The measuring beginning of the capacitive level meter (Figure 8) is the determination of the capacitance presented by varying the level in a container.

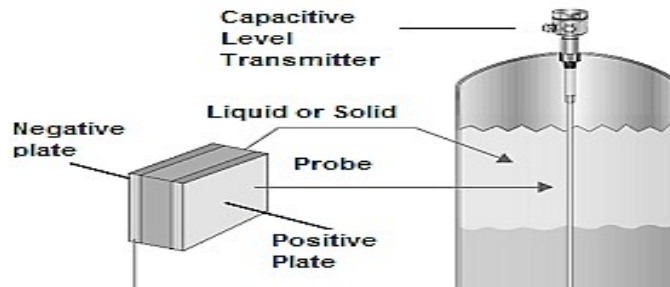

Figure 8. Capacitive level meter. **Source:** [37].

In this beginning of measurement, the container wall acts as a capacitor plate and the measured product acts as the other plate. When the measured product is electrically nonconductive it acts as a dielectric. When the measured product is electrically conductive the probe insulation is who acts as dielectric [37]. Through this measuring principle, continuous level measurement can be carried out (with a transmitter) and measurement of the point level (with interrupter).

$$C = \frac{K * A}{D} (7)$$

In the case of continuous level measurement, the total area A , is the sum of the area of the container wall plus the area of the probe level transmitter. The distance D , is the minimum that occurs between the probe and the container wall. Note that both the area and the distance are values that remain constant. When the

probe is surrounded by vapor or air, it is a dielectric constant (K_1), and when the probe is surrounded by the product it is measured with a dielectric constant (K_2). Then the capacity change is directly related to the change occurring in the middle, it is to say, the changing of constant dielectric, as it can be seen in (8), [46].

$$\text{Change of capacity} = (K_2 - K_1) * \left(\frac{A}{D}\right) \quad (8)$$

In point level measurement, capacitive meter is mounted horizontally, there, the tank wall forms a plate and the meter probe forms another. The measurement is done by sending an RF (radio Frequency) signal from the probe which is isolated with a material of low dielectric constant. The meter detects the difference of constant dielectric occurring between the air and the measured product and then it translates this in the change of the state of a relay [46]. Some capacitive level transmitters have auto calibration, detecting the changes that occur in the dielectric constant of the product [23], [44]. The capacitive level transmitter has a fast response speed and manages to make a reliable measurement in liquid interface level [37]. For a better understanding of capacitive level measurement is recommended see [47].

5.5. Radiometric level meter

The radiometric level meter, fig 9, It's composed of a source of gamma rays and a radiation detector. The source has a very small size and is immersed in a container filled with lead. The radiation detector, which serves as the transmitter, may be: a Geiger counter, an ion chamber or a scintillation detector. Once the gamma rays are emitted, they penetrate the solid or liquid to be measured and as the level increases, there is a decrease in the intensity of gamma rays received. For the meter to function properly the radiation source should be mounted parallel to the detector, as can be seen in Figure 9, [43], [48], [37].

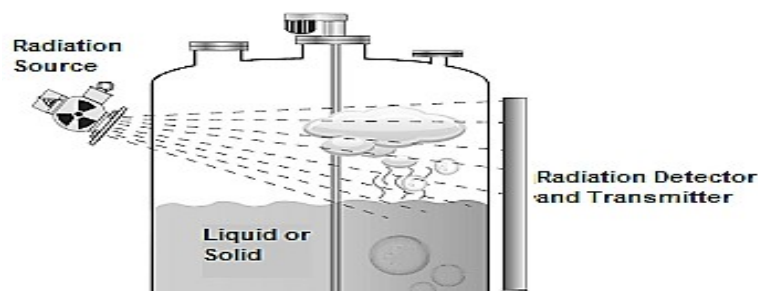

Figure 9. Radiometric Level Meter or Gamma Ray Meter [37].

Generally, radiometric level meter is not affected by extreme temperatures and pressures and normally, it is the ideal solution in cases where another meter cannot be implemented [49]. The cost of the radiometric level meter is relatively high (it could cost between 2-4 times more) and it requires periodic inspections because of the risk to the staff of this process [44]. In [50] we can see in detail how the meter performs the radiometric level measurement.

5.6. Direct Level Measurers

Direct Level gauges are in contact with the liquid, they give the user a direct indication and they mainly operate mechanically. Below, meters operating under this concept are presented.

5.6.1. Magnetic level indicator

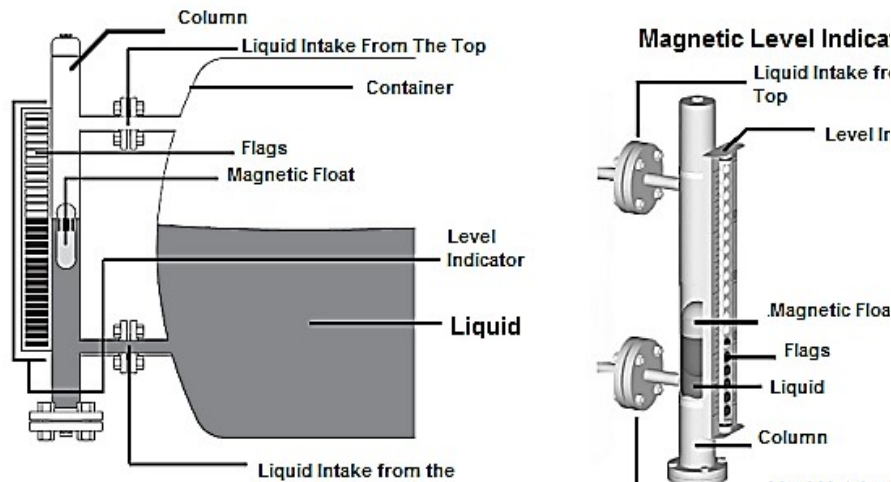

Figure 10. Parts of a magnetic level indicator [51], [52].

The magnetic level gauge, Figure 10, has a float that carries a series of magnets inside and which is inside of a column, it also has liquid entering from the top and bottom of the container. The magnets produce a

A Current Vision

magnetic field that spins a series of flags, which they have a different color on each side, so that as the level increases the float rises and the flags rotate (changing color and indicating the level on the outside of the container). The containers in which you want to install this indicator should be designed so that they can divert some of the liquid into the column in which the float is found [51]. Manufacturers of magnetic level indicators offer a number of materials so they can be implemented under extreme conditions, such as floats of different materials for different types of liquids [28]. To understand in detail the operation of magnetic level gauge it is recommended to see [53].

5.6.2. Magnetostrictive level meter

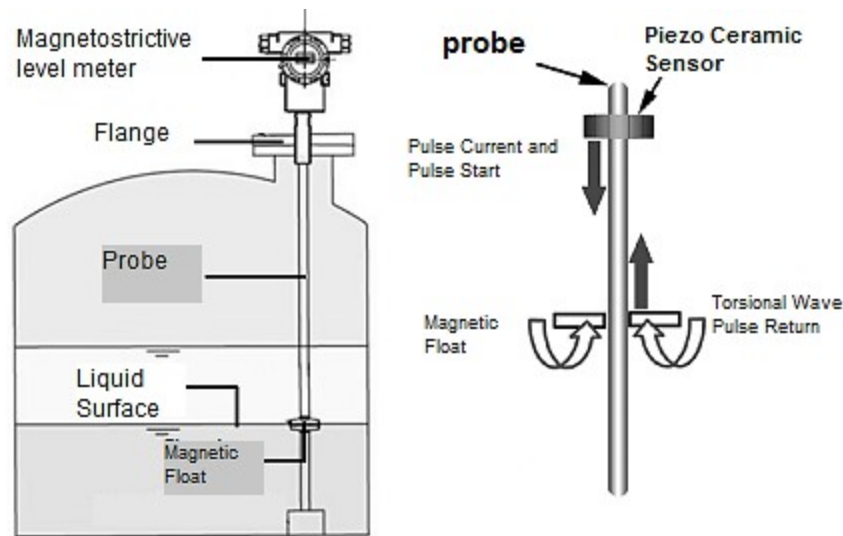

Figure 11. Magnetostrictive level meter. **Source:** [54], [28].

The Magnetostrictive level meter, Figure 11, is a transmitter that sends current pulses through a tensioning wire which is inside a probe (made of magnetostrictive material³) and generating a magnetic field there around. Once this occurs, a timer circuit is activated. The float that has the meter (which moves the measuring probe) it axially magnetizes the wire generating a magnetic field which interacts with the field generated in the measuring probe. When the two magnetic fields overlap, a torsional pulse propagating with ultrasonic speed in both directions is generated and then travels to a piezoceramic sensor, in the upper part of the transmitter, generating an electrical signal which stops the timer circuit.

3 Magnetic materials that change shape to be in the presence of a magnetic field.

Subsequently, the timer circuit measures the travel time interval pulse current for the meter to provide information, precisely, on the liquid level in the tank, [55], [56], [28].

5.7. Laser level meter

Laser level meter, Figure 12 is a transmitter that sends a beam of light onto the surface of the product of the process so that, once having contact with the product surface, it returns back to the transmitter. The transmitter, with the help of a timer circuit, calculates the travel time of the beam and calculates the distance, as shown in (9).

$$D = \frac{V * t}{2} \quad (9)$$

Where “**D**” the distance from the meter to the product surface is, “**t**” is the elapsed travel time of the beam and “**V**” is the speed of the light. [1], [28].

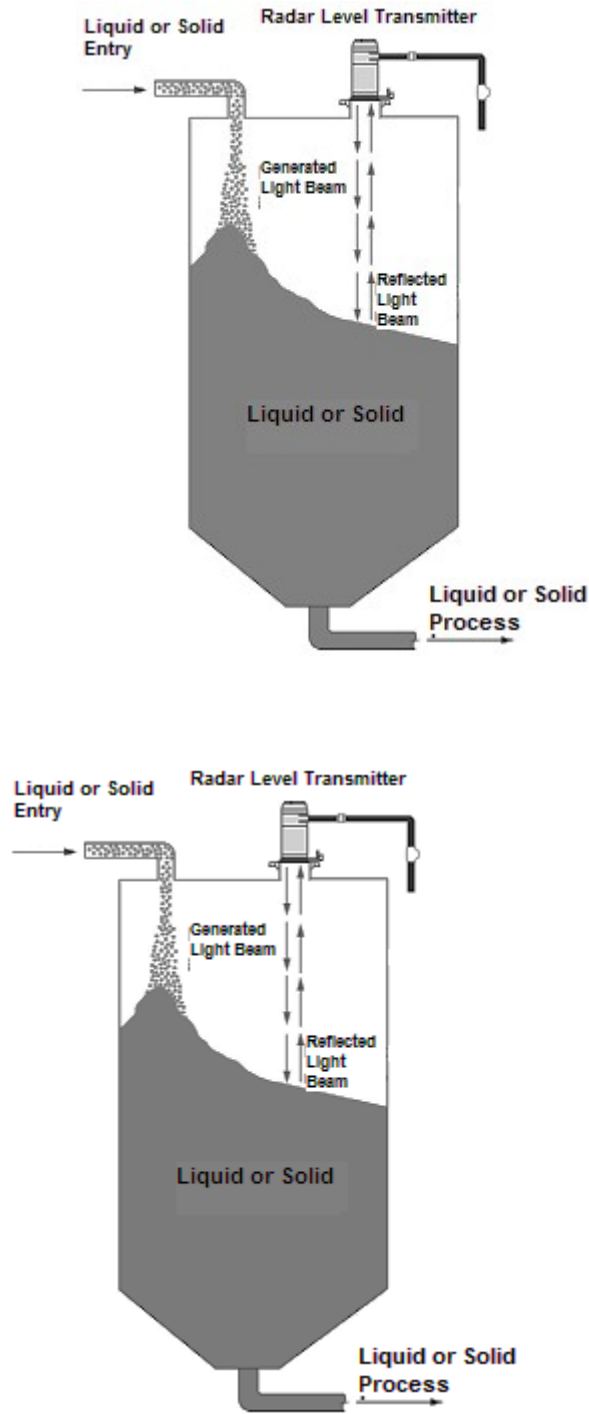

Figure 12. Transmitter laser level [28].

This meter is not affected by the steam generated at the top of the liquid, or by the constant dielectric of liquid.

The light beam emitted presents virtually no dispersion, to the point that it can be implemented in very narrow places or are difficult to access with a range of up to 1,500 feet [28], [57].

5.8. Vibrating level meter

The vibration level meter, Figure 13, it is a switch having two piezoelectric oscillators that are within a hollow tube and that vibrate thanks to the natural frequency of a piezoelectric crystal. These oscillators are also known as vibrating forks and once they are "reached" by the product, they will have a change in their resonance frequency.

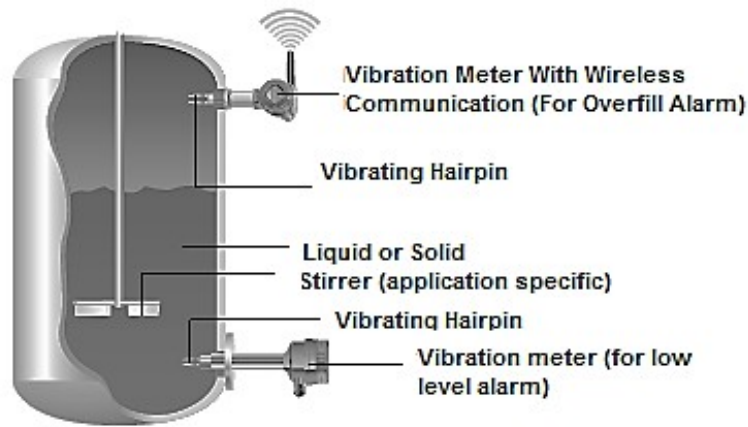

Figure 13. Vibrating level switch for alarm application. For low-level and high-level alarm [25].

When the meter is used as a low level alarm, the tank level drops below the hairpin, presenting an increase in resonance frequency. When the meter is used as a high level alarm, tank level rises to reach the vibrating fork and present a decrease in resonance frequency. And this way, the more density that is shown in the hairpin, the lower the resonance frequency [23], [58]. It is recommended see [59], and it will show in detail the operation of vibration level meter.

6. Conclusions

A Current Vision

- The level is a very important variable in different industrial processes and to carry out an adequate measurement. It is important to select a meter that meets the needs of the process, avoiding any inconvenience that may arise from their own or other product measurement factors. Proper comprehension of each of the measurement principles help greatly so that selection can be carried out with the least amount of mishaps.
- In level measurement there are various operating principles that can be found, of which, in this article the following were reviewed: Bubbling, differential pressure, guided wave radar, radar noncontact, ultrasound, capacitive, radioactive, magnetic indicator, magnetostrictive and laser level. These measurement principles were disclosed in a simple manner, so that such parameters are taken as clear as possible like: Parts of the meter, equation governing or ruling its functioning, physical properties, environmental properties, among others. In addition, some application considerations were released based on the criteria of the manufacturers.
 - In the industry it is possible to find processes in which there are certain solids or liquids of complex processing that cannot be measured by any kind of instrument. Typically, the most suitable meters for such products are those working meters without contact. Then it is important to perform a cost-benefit analysis, taking into account the value of the meter, as well as costs associated with installation and maintenance.
- This article provides a basis for future research work in which industries publicize the application and selection criteria of a level meter. It is understood in some applications, products that must be treated hygienically (like the ones in food process) oily or viscous liquids, containers with agitators, corrosive liquids, liquids that vary in their density, foamy liquids, products in tight containers or that are difficult to measure, among other aspects. Regarding the selection criteria, it must be said that there are a series of questions that must be made, based on the needs of the industry application. Some of these criteria are as follows: container shape, the properties (physical, environmental or electrical) of the product, environmental conditions of the process, the degree of involvement of the product in the meter or vice versa, the accuracy required, the output signal required treatment, among others.

References

- [1] A. Creus, "Medición de nivel," in Instrumentación industrial, Octava ed., Alfaomega, Ed.

Barcelona, pp. 195–230, 2010.

- [2] Rosemount Inc, “Documentación y planos Rosemount.” Mar 2016, [Online] available: <http://www2.emersonprocess.com/es-es/brands/rosemount/documentation-and-drawings/pages/index.aspx>
- [3] Vega Americas Inc, “Zona de descarga.” Mar 2016, [Online] available: https://www.vega.com/es-ES/home_co/Zona-de-descarga
- [4] ENDRESS+HAUSER Management, “Downloads.” Mar 2016, [Online] available: <http://www.endress.com/en/downloads>
- [5] MAGNETROL International Inc, “Resources.” Mar 2016, [Online] available: <http://us.magnetrol.com/Downloads.aspx?Id=0>
- [6] VEGA Americas Inc, “Energías renovables: tecnología de medición para un sector progresista.” Mar 2016, [Online] available: https://www.vega.com/home_mx
- [7] J. Boisvert, “Keep measurements on the level,” *Chemical processing*, p. 2/12, Nov 2006
- [8] J. Foszcz, “Selecting liquid level for detectors tanks,” *Plant engineering*, 1998.
- [9] OMEGA Engineering, “Specialty level switches,” in *Transactions: flow and level measurement*, Stanford, pp. 102–105, 2001.
- [10] “Interruptor de nivel conductivo.” Jun 2016 [Online] available: <http://www.directindustry.es/prod/kfg-level/product-25136-61411.html>
- [11] “Indicadores de nivel de cristal plano.” Apr 2016, [Online] available: http://www.idisal.com/indicadores_de_nivel.html
- [12] I. Muller, R. Machado De Brito, C. E. Pereira, and V. Brusamaello, “Load Cells in Force Sensing Analysis-Theory and a Novel Application,” *IEEE Instrum. & Measurement Mag.*, no. February, pp. 15–19, 2010.
- [13] VEGA Americas Inc, “Múltiples soluciones con plics plus.” 2015, [Online] available: https://www.vega.com/es-ES/home_sr/Productos/Product-compare?category=%7B4EC26DE1-DB67-47C3-AA45-F5FC38897296%7D
- [14] “Introducción a La Instrumentación Industrial.” Apr 2016, [Online] available: <http://www.tav.net/transductores/instrumentacion-industrial.pdf>
- [15] A. Creus, “Generalidades,” in *Instrumentación industrial*, Octava ed., Alfaomega, Ed. Barcelona, pp. 3–16, 2010.
- [16] “Sensores: Definición y características,” *Control real español*, 2015. [Online] available:

<http://controlreal.com/es/sensores-definicion-y-caracteristicas/>

- [17] “Qué es un sensor.” Apr 2016, [Online] available:
http://www.profesormolina.com.ar/tecnologia/sens_transduct/que_es.htm
- [18] A. Creus, “Transmisores,” in *Instrumentación industrial*, Octava ed., Alfaomega, Ed. Barcelona, pp. 63–88, 2010.
- [19] F. Brissaud, A. Barros, C. Bérenguer, and D. Charpentier, “Reliability analysis for new technology-based transmitters,” *Reliab. Eng. Syst. Saf.*, vol. 96, no. 2, pp. 299–313, Feb. 2011.
- [20] M. A. Oliva Vallejos, J. D. Lopez, and A. Diaz Escobar, “Sensor de nivel inteligente para el control de tanques hidráulicos,” Tesis para optar al título de tecnólogo en electrónica, Universidad Distrital Francisco José de Caldas, Colombia, 2015.
- [21] “Introducción a la medición de nivel.” Apr 2016, [Online] available:
<http://mx.omega.com/prodinfo/medicion-de-nivel.html>
- [22] D. Gillum, “Level measurement: from tried and true to the newest trends,” *Intech*, pp. 1–4, jan-feb, 2013.
- [23] A. S. Morris and R. Langari, “Level measurement,” in *Measurement and instrumentation*, Elsevier, pp. 461–475, 2012.
- [24] “Bubbler Type Level Measurement Device.” Apr 2016, [Online] available:
http://automationwiki.com/images/4/4b/Bubbler_Type_Level_Measurement.jpg
- [25] ROSEMOUNT Inc, “Rosemount level instrumentation: the right technologies for optimal results.” Shakopee, pp. 4–39, 2015.
- [26] D. Gunn, “Differential pressure sensors,” Honeywell process solutions, pp.5-6, February 2010.
- [27] ENDRESS+HAUSER Management, “Technical Information: Deltabar FMD71, FMD72.” Reinach, pp. 7–9.
- [28] ABB, “A dozen ways to measure fluid level and how they work” Sensor Online, pp. 5–6, 2013.
- [29] ENDRESS+HAUSER Management, “Technical information: Deltabar S PMD75, FMD77, FMD78.” Reinach, pp. 7–9, [Online] available:
https://portal.endress.com/wa001/dla/5000524/7248/000/02/TI01033PEN_0312.pdf
- [30] ENDRESS+HAUSER Management, “Medición de presión: instrumentos para la medición de presión , presión diferencial , nivel y caudal de proceso.” 2016, [Online] available:
<http://pe.ecnautomation.com/wp-content/uploads/2015/01/Pes.pdf>
- [31] C. Lamakul, “Advancements in radar level,” *InTech Magazine*, 2003.

- [32] S. Parker, "Diverse uses for level radar," ISA, May 2016, [online] available: <https://ww2.isa.org/standards-and-publications/isa-publications/intech-magazine/2002/may/diverse-uses-for-level-radar/>
- [33] MAGNETROL International Inc, "Guided wave radar technology." Apr 2016, [Online] available: http://mx.magnetrol.com/Technologies_Individual.aspx?Id=5
- [34] MAGNETROL International Inc, "Eclipse: modelo 705 2da generación." Aurora, p. 1, 2012.
- [35] E. Fauveau and K. Hambrice, "Guided wave radar helps level detection in harsh settings," *Consulting specifying engineer*, Marzo 2003.
- [36] ROSEMOUNT Inc, "Rosemount serie 5300." Shakopee, pp. 2–4, 2014.
- [37] H. Gene, "Basics of continuous level measurements." Reinach, p. 6, 2015.
- [38] ENDRESS+HAUSER Management, "Sistema de seguimiento de ecos en la medición de nivel por radar guiado," 2011. [Online] available: https://www.youtube.com/watch?v=EO9zOT_Ulu8&index=2&list=PLQRFGW1Z4TGGxAhGySONm0xVEo2fXjW77
- [39] ENDRESS+HAUSER Management, "Diagnósticos avanzados: detección de espumas - medición de nivel de radar," 2015. [Online] available: https://www.youtube.com/watch?v=uxt86zxN_B8&list=PLQRFGW1Z4TGGxAhGySONm0xVEo2fXjW77&index=5
- [40] VEGA Americas Inc, "Ultrasonido: resumen de producto." 2016 [Online] available: <https://www.vega.com/DocumentDownloadHandler.ashx?documentContainerId=2806&languageId=6&fileExtension=pdf&documentGroupId=29023>
- [41] N. Sheble, "Ultrasonic is on the level," *Intech*, 2005.
- [42] ROSEMOUNT Inc, "Transmisores ultrasónicos Rosemount 3101 , 3102 y 3105 para medida de nivel de líquido." Shakopee, pp. 3–4, 2013.
- [43] OMEGA Engineering, "Radiation based level instrumentation," in *Transactions: flow and level measurement*, Stamford, pp. 93–101, 2001.
- [44] M. Bahner, "A practical overview of level measurement technologies." 2016, [Online] available: <http://www.gilsoneng.com/reference/Levelpap.pdf>
- [45] ENDRESS+HAUSER Management, "Ready for take - off: principio de 'tiempo de retorno' (TOF)," 2010. [Online] available: <https://www.youtube.com/watch?v=KmK0VulQM0g>
- [46] OMEGA Engineering, "RF/Capacitance Level Instrumentation," in *Transactions: flow and level measurement*, pp. 87–92. Stamford, 2001.
- [47] ENDRESS+HAUSER Management, "Animación de la compensación activa de adherencias -

- sondas capacitivas,” 2013. [Online] available: <https://www.youtube.com/watch?v=kljAjbYsW7Y>
- [48] ENDRESS+HAUSER Management, “Technical information: Gammapilot FTG20.” Reinach, 2013. [Online] available: <http://www.endress.com/en/Field-instruments-overview/level-measurement/Radiometric-Gammapilot-FTG20>
- [49] VEGA Americas Inc, “Tecnología de medición radiométrica.” 2013. [Online] available: https://www.vega.com/es-ES/home_us/Productos/Cat%C3%A1logo-de-productos/Medici%C3%B3n-de-nivel/Radiometr%C3%ADa
- [50] ENDRESS+HAUSER Management, “Principio de medida radiométrico,” 2015. [Online] available: <https://www.youtube.com/watch?v=pMbclVYQsoM&index=7&list=PLQRFGW1Z4TGGxAhGySONm0xVEo2fXjW77>
- [51] ORION Instruments, “A guide for selecting the right magnetic level indicator.” Baton Rouge, pp. 1–4, 2013.
- [52] “Indicador de nivel magnético.” Jun 2016, [Online] available: <http://www.directindustry.es/prod/sart-von-rohr/product-98999-927189.html>
- [53] JERGUSON, “Indicador de nivel magnético Magnicator II Flashproof en español,” 2015. [Online] available: <https://www.youtube.com/watch?v=qIA35IRsfu4>
- [54] DALIAN METERY TECHNOLOGY Co., “Catalog of Industry Meters.” [Online] available: <http://catalog.gpi.net/asset/industrial-flow-meters-catalog-version-7-rev-b.pdf>
- [55] KOBOLD Instruments Inc, “Medidores de nivel magnetostriictivos.” pp. 1–2, Jun 2016, [Online] available: <http://www.iac-sl.es/sites/default/files/2MAGNETOESTRICTIVO.pdf>
- [56] “Cómo funciona un medidor de nivel,” *Blog de instrumentación de WIKA*, 2012. [Online] available: <http://www.bloginstrumentacion.com/blog/2012/07/19/como-funciona-un-medidor-de-nivel/>
- [57] D. Spitzer, “Lasers come to level measurement,” *Control*, 2006.
- [58] ROSEMOUNT Inc, “Dispositivo Rosemount 2120.” Shakopee, pp. 2–3, 2013.
- [59] ENDRESS+HAUSER Management, “Principio de medición vibratorio,” 2015. [Online] available: <https://www.youtube.com/watch?v=FL5Tg4sRrmk&list=PLQRFGW1Z4TGGxAhGySONm0xVEo2fXjW77&index=10>