

Evaluation of traditional grain store buildings (*hórreos*) in Galicia (NW Spain): analysis of outdoor/indoor temperature and humidity relationships

O. A. Perez-García¹, X. C. Carreira¹, E. Carral^{2*}, M. E. Fernández¹ and R. A. Mariño¹

¹ Department of Agroforestry Engineering, University of Santiago de Compostela, Escola Politécnica Superior, Campus Universitario, 27002 Lugo, Spain

² Department of Cellular Biology and Ecology/IBADER (Institute for Rural Development and Biodiversity), University of Santiago de Compostela, Escola Politécnica Superior, Campus Universitario, 27002 Lugo, Spain

Abstract

Hórreos are traditional rural buildings of northern Spain used for desiccation and conservation of cereal grains. They provide natural ventilation, an unfavourable environment to discourage attack by biotic agents (*e.g.*, fungi and insects) and prevent access by others, such as rodents. The objective of this paper was to study the environmental conditions of the Mondoñedo type of *hórreos* (north coastal area of Galicia, northwestern Spain). They are built of wood and stone, with a prismatic grain chamber isolated from the ground and with ventilation openings on the side walls. In three *hórreos*, over a period of one month, the temperature (T) and relative humidity (RH) of the indoor and outdoor air were measured throughout the day. Maximum and minimum values during three periods (night, morning and afternoon) and at three specific times (9:00, 14:00 and 21:00) were analysed. It was noted that *hórreos* had a dampening effect on RH. When the outdoor humidity was $\geq 90\%$, the indoor humidity was on average 5.2% lower. If the outdoor humidity was $\leq 65\%$, the indoor humidity was on average 3.2% higher. When it was around 75%, this effect was at its smallest. This effect was not as remarkable for T. It is concluded that RH and, to a lesser extent, T remain more stable in the *hórreo* than outdoors, providing an appropriate environment for the preservation of grain. Other characteristics (*i.e.*, geographical location, topographic altitude, exposure to the wind and longitudinal axis direction) appear to influence the amount of change experienced by these parameters.

Additional key words: ambient parameters analysis; cereal grain conservation; rural traditional buildings.

Resumen

Evaluación de construcciones tradicionales para el almacenamiento de granos (*hórreos*) en Galicia (NO de España): análisis de las relaciones entre la temperatura y humedad interior y exterior

Los *hórreos* son construcciones rurales tradicionales del norte de España usadas para la desecación y conservación de granos de cereal. Sus características proporcionan ventilación natural y un ambiente desfavorable para el ataque de agentes bióticos (como hongos o insectos), además de evitar el acceso de otros, como roedores. El objetivo de este trabajo fue estudiar las condiciones ambientales de los *hórreos* tipo Mondoñedo (zona costera norte de Galicia, noroeste de España). Están contruidos de madera y piedra, con una cámara de grano prismática aislada del suelo y con aberturas de ventilación en sus paredes laterales. En tres *hórreos*, durante un periodo de un mes, se midieron la temperatura y la humedad relativa del aire interior y exterior a lo largo del día. Se analizaron los valores máximos y mínimos durante tres periodos (noche, mañana y tarde) y a tres horas determinadas (9:00, 14:00 y 21:00). Se observó que los *hórreos* tenían un efecto amortiguador sobre la humedad relativa: Cuando la humedad exterior era $\geq 90\%$ ó $\leq 65\%$, la humedad interior era, como media, un 5,2% inferior o un 3,2% superior, respectivamente; si era $\sim 75\%$ el efecto era el más reducido. Para la temperatura, este efecto no era tan destacable. Se concluye que la humedad relativa y, en menor medida, la temperatura permanecen más estables dentro del *hórreo*, proporcionando un ambiente apropiado para preservar el grano. Otras características (como localización geográfica, altitud topográfica, exposición al viento y dirección del eje longitudinal) parecen influir en el nivel de variación experimentado por las variables.

Palabras clave adicionales: análisis de parámetros ambientales; conservación de cereales; construcciones rurales tradicionales.

* Corresponding author: emilio.carral@usc.es

Received: 07-04-09; Accepted: 21-07-10.

X. C. Carreira, M. E. Fernández and R. A. Mariño are members of the SEA.

Introduction

The grain store, or *hórreo*, typical of Galicia (north-western Spain) is a rural building for storing grains of cereal, mainly maize (*Zea mays* L.). There are about thirty thousand of these buildings in this region. They are of great importance from historical, anthropological, economic, architectural and cultural points of view. The word «*hórreo*» apparently has its origins in *granarium horreum*, the name given by the Romans to a special kind of grain store (De Llano, 1983). In the early 17th century, the arrival of maize in Galicia from the American continent marked the beginning of an important specialisation of these buildings for the preservation of this cereal.

The conservation of cereals in general and maize in particular involves careful storage to prevent damage by biotic and abiotic agents. White (1992) indicated that grain bulks form distinct ecosystems in which the grains and communities of insects, mites, microflora and, occasionally, rodents and birds interact in a single environment. Food availability and proper environmental conditions will favour the growth of fungi and insects. Therefore, the control of these agents is different from that of rodents and birds, where one key is to limit physical access.

The temperature and humidity can be considered as fundamental abiotic agents; high values favour the germination of seeds and affect their quality characteristics and also encourage the development of some biotic agents (fungi, insects).

In the case of fungi, grains transport microflora and storage fungi whose ability to germinate depends on the availability of water in the substrate, temperature and intragranular gas composition (Magan and Lacey, 1988; Gagliu *et al.*, 2007). Monitoring the biophysical conditions of storage is necessary for mould management (Yigezu *et al.*, 2008; Rozman *et al.*, 2008).

Temperature management is also a biorational tool to control insects (Phillips and Throne, 2010), although the humidity and the presence of damaged grains also influence the likelihood of insect attacks (Cox and Collins, 2002).

Therefore, the Galician *hórreo* is more than just a granary. It is also involved in desiccation of the grain to guarantee its preservation, due to its geometric and

architectural characteristics. There are different sorts of *hórreos* depending on the shape of the building, the roof features, the supports, the kind of materials used and the geographical location (De Llano, 1983; Martínez Rodríguez, 1999). In the coastal areas near the Cantabrian Sea (the Mariña Central area in the province of Lugo) there are two types, Ribadeo and Mondoñedo. Usually, the Mondoñedo *hórreos* preserve traditional features in a better form. The fundamental difference between them is the material used to construct the side walls (wood in the Mondoñedo type and stone in the Ribadeo type).

These *hórreos* are tall, narrow buildings with a rectangular layout. They have raised floors that insulate them from the ground and prevent access by rodents. They also have numerous openings in the side walls to permit natural ventilation and control the indoor relative humidity (RH_i). In this way, the grain desiccation is supported as well as the maintenance of an optimum humidity level of the grain. The *hórreos*' characteristics meet current energy-efficient criteria, in this case with null energy consumption, within the context in which they were conceived. This is the case of traditional buildings that are adapted to the environment (Chen *et al.*, 1997; Sozen and Gedik, 2007; Van Hoof and Van Dijken, 2008). Other traditional buildings may also be adapted to the climatic characteristics of their geographic location (Oktay, 2002).

The hypothesis considered in this paper regarding *hórreos* was that their particular building features permit natural ventilation and make particular indoor environmental conditions possible; thereby, they offer adequate conditions for storage of grains. In a broader sense, they serve as an example of traditional buildings that meet the present criteria of energy-efficient design of buildings (*i.e.*, with lower energy consumption during use, in this case no energy consumption).

The aim of this paper was to study the indoor environmental conditions of Galician *hórreos*. For this purpose, the RH and air T were measured outside and inside of three *hórreos* of the same type (Mondoñedo) located in different geographic locations (coastal or mountain area) in municipalities adjacent to the Cantabrian Sea in the Galician province of Lugo.

The comparative analysis between indoor and outdoor parameters at different times of the day had three

Abbreviations used: RH (relative humidity), T (temperature), RH_i (indoor relative humidity), RH_o (outdoor relative humidity), T_i (indoor temperature), T_o (outdoor temperature), RH_{max} (maximum relative humidity), RH_{min} (minimum relative humidity), T_{max} (maximum temperature), T_{min} (minimum temperature).

goals: i) to estimate whether the natural regulation of the environment by the constructive characteristics of the *hórreo* led to significant differences between the characteristics of the indoor and outdoor air; ii) to define the relationships that permit estimating the indoor foreseeable RH and T based on external values; and iii) to investigate whether any factor can explain most of the variation in environmental parameters of the *hórreos* with respect to the outside air characteristics.

Material and methods

Building description

The Galician *hórreos* have two basic design features. The first is the separation of the body of the building from the ground. It is a room, a grain chamber with a floor raised on support elements. The second is the numerous openings in the walls to encourage ventilation. The structure and the walls can be constructed of wood or stone. The covering material can be slate or tile. All of these features are used as classification criteria (De Llano, 1983; Martínez-Rodríguez, 1999).

The grain chamber is insulated from the ground using bases or support elements (called «feet», «pies» in Spanish, or «pes» in the Galician language). These elements permit the isolation of the chamber from soil moisture while placing it at a greater height to facilitate ventilation and to prevent access by rodents. The bases can be either individual supports or continuous masonry prisms. There are also elements made of stone between the bases and the grain chamber that are used to prevent rodents from climbing the supports.

The material used to construct the walls can be wood or stone. In both cases, gaps or openings are constructed to facilitate ventilation. When wood boards are used to construct the side walls, they are placed vertically and separated by about 1-2 cm, forming narrow openings. In stone walls, the gaps are formed because the stone blocks do not fit perfectly together.

There are different types of *hórreos* according to the characteristics of the parts described above. This study aimed to analyse a particular type, the Mondoñedo *hórreo*, which is found in the towns of the coastal area near the Cantabrian Sea in the province of Lugo (Figs. 1 and 2).

This is a mixed type in which wood and stone are used. It has a rectangular layout with a prismatic grain chamber. The width and height of the chamber tend to be similar

in all *hórreos*, while the length varies from one to another. The chamber rests on the feet but is separated from them by an element of stone (usually flat) designed to prevent rodents from accessing the chamber («*tor-narratos*» in the Galician language, a word derived from «*tornar*», turn off, and «*ratos*», mice). The chamber floor can be made of wood or stone (slate or granite).

The roof structure consists of a wooden beam at the ridge. There may or may not be intermediate beams that support this piece. The rafters are supported on the ridge beam and the beam located at the top of the wall. This beam is part of the structure of the beams and columns of the chamber. The roofing material is usually slate.

The walls are made of wooden boards with a slight separation between them. The front walls can be made of continuous granite or stone masonry. In one of the front walls, there is an access door to the grain chamber; if the access door is not in this position, it is located in one of the side walls.

Selection of the *hórreos* to study

The selection of the *hórreos* to study was based on a previous study done by the authors in which all of the Mondoñedo-type *hórreos* of Galicia were inventoried (1,656 in total). This inventory included the construction features, location and orientation of each one.

In the first phase, a selection among all the *hórreos* in the inventory was done, retaining those with the following features: no construction deficiencies, currently in use and having all of the structural characteristics typical of a Mondoñedo-type *hórreo* without later additions. Among the buildings selected in this phase, a second selection was done, forming groups of those with different geographic locations (inner zone, coast and intermediate), altitudes (valley or mountain) and wind exposures (normal or high exposure). From this group of *hórreos*, three were chosen for which the cooperation of the owners permitted more reliable data collection. In the text, they will be referred to as *hórreos* number 1, number 2 and number 3.

Their specific geographic locations are shown in Figure 3 and their descriptive data are listed in Table 1. The building features were similar across the three examples, including their height from the ground. The open area for ventilation in the longitudinal side walls was 11% of the total area of these walls. The ratio of height to width ranged between 1.4 and 1.7. Three *hórreos* with similar building features were selected

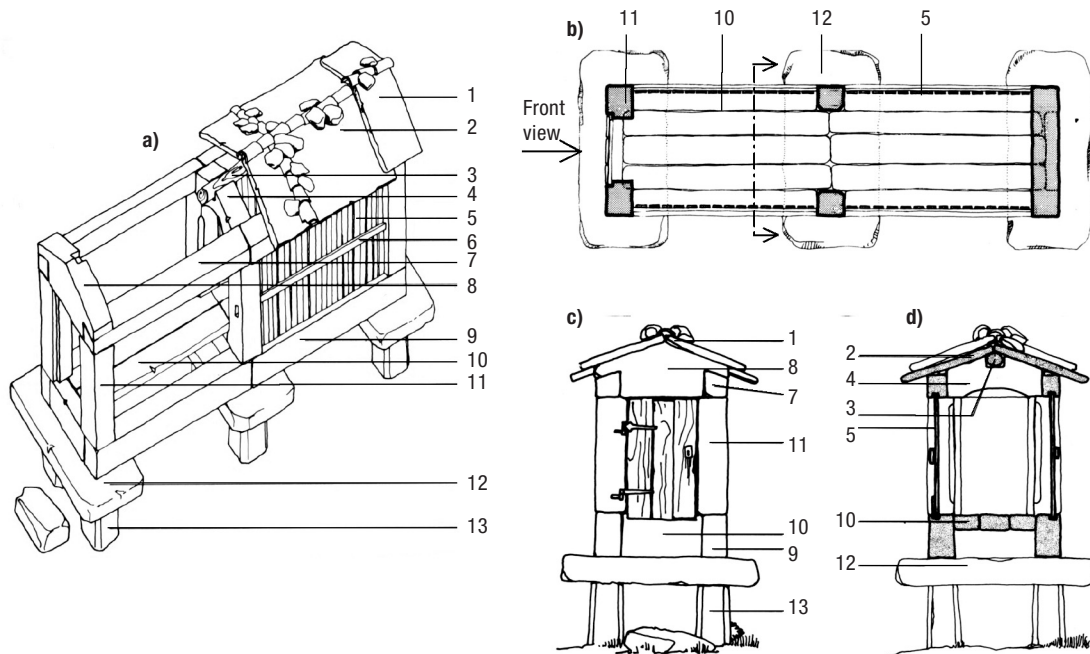

Key	Galician language	Spanish	English
1	Sobrepena	Vierteaguas	Overhanging eave
2	Cubrición de lousas	Cubierta de pizarra	Roof covering of slates
3	Cume	Cumbrera	Ridge
4	Tixeira	Viga de cubierta	Rafter
5	Bagalustos	Tablas de cerramiento	Closing boards
6	Cinta	Travesaño	Wall girt
7	Soleiras	Viga de alero	Eave beam
8	Peche do penal	Hastial	Gable end
9	Trabes	Viga de solera	Floor beam
10	Piso	Piso	Floor
11	Colunas	Pilares	Columns
12	Cepas/tornarratos	«Desvía-ratones»	Flat stone to keep off rodents
13	Pes	Pies/bases	Feet

Figure 1. Parts of a Mondoñedo-type *hórreo*: a) three-dimensional view, b) layout, c) front view and d) section. *Source of drawings:* De-Llano (1983).

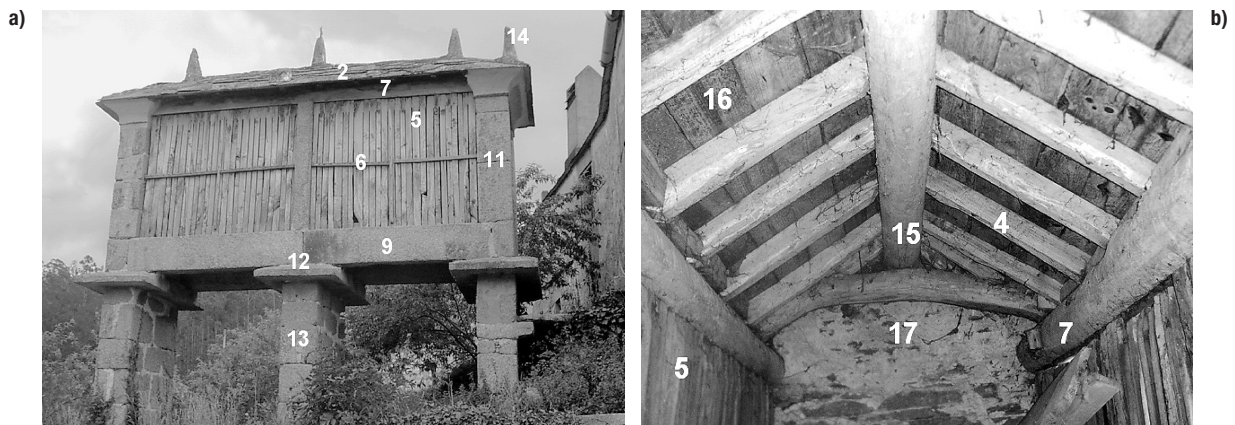

Figure 2. A Mondoñedo-type *hórreo*: a) outdoors: 2) roof covering of slates, 5) closing boards, 6) wall girt, 7) eave beam, 9) floor beam, 11) columns, 12) flat stone to keep off rodents, 13) feet and 14) roof decoration stones; and b) indoors: 4) rafter, 15) ridge-piece, 16) wood board roof sheeting to support slates and 17) back wall.

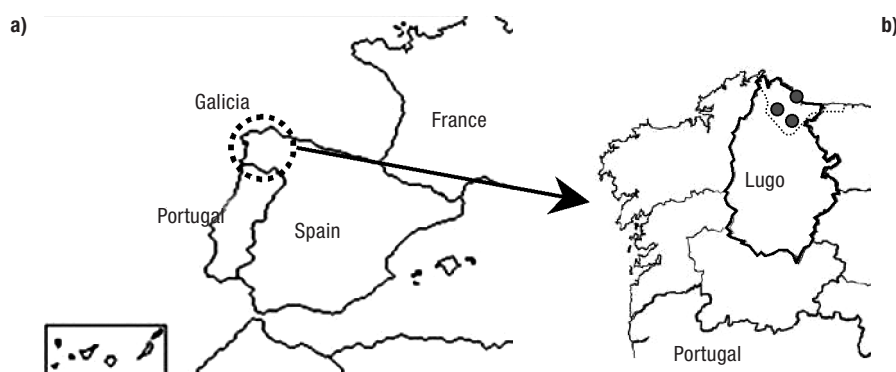

Figure 3. Geographical locations of the studied *hórreos*: a) Galicia and b) locations of the *hórreos* in the coastal area of Lugo.

to facilitate analysis. The differences among them were in their geographic and topographic features related to the places where they were built (geographic location, topographic altitude, degree of exposure to the wind) and the direction of their longitudinal axes.

Selected and examined variables

RH and air T were measured both indoor (i) and outdoor (o) the chambers of the *hórreos*. The measurements were taken in *hórreo* number 1 during the summer of 2006 (from 1st August to 30th September) and in *hórreos* number 2 and number 3 during the

autumn of the same year (from 1st October to 30th November). Because of the time schedule chosen in the study, details for 168 days were obtained. All measurements were made with empty *hórreos*.

Three daily measurement periods were established, morning (m), afternoon (a) and night (n), with the aim of capturing the fluctuations in temperature and humidity during both sunlight and night periods. These periods were defined as follows: night period (from midnight to 11:00), morning period (from 11:00 to 16:00) and afternoon period (from 16:00 to 24:00).

Three characteristics of each of the environmental parameters were recorded during these periods: a current measurement (c), the parameter's value at the time of

Table 1. Features of the studied *hórreos*

Feature	<i>Hórreo</i>		
	Number 1	Number 2	Number 3
Geographical location	Midway between the mountains and coast, 10 km from the coast. Municipality of Mondoñedo	Coastal, close to the coast. Municipality of Foz	Midway between the mountains and coast, 10 km from the coast. Municipality of Mondoñedo
Degree of wind exposure	Exposed	Normal	Exposed
Topographic altitude, m	140	60	120
Direction ¹	NW-SE	N-S	E-W
Dimensions			
Length, m	4.30	5.20	5.00
Width, m	1.20	1.30	1.45
Height ² , m	2.00	2.15	2.00
Material of structural elements ³	Granite stone		
Roofing material	Slate		
Lateral wall closure	7-cm wide wooden boards separated by 1 cm		

¹ Direction of the longitudinal axis of the *hórreo*. ² Eave height. ³ Columns, front walls, floor beams and bases («feet»).

reading (at 9:00, 14:00 and 21:00); the maximum measurement (max), the maximum value during the period; and the minimum measurement (min) or the minimum value during the period. In each *hórreo*, nine measurements were taken inside and another nine outside, three for each time period, for both RH and T. Therefore, there were 18 study variables for RH and the same number for T.

To carry out measurements, two thermo-hygrometers were used, one situated inside the chamber and the other outside. These devices have one central unit that can measure T and air RH. They also have an internal memory that enabled data to be stored and provided maximum and minimum values for a specific period. The sensitivity was $\pm 1^\circ$ for T and $\pm 0.1\%$ for RH.

The data obtained for environmental variables were analysed using SPSS version 17. First, the means were compared to determine if there was a difference between outdoor and indoor variables (using a t-test for normally distributed variables and Mann-Whitney test for the others). The significance level was set at 0.05. Linear regression analyses were conducted to determine correlations between the indoor and outdoor

variables. Finally, a factor analysis was performed to confirm the existence of correlated homogeneous groups within the examined variables. KMO and Bartlett tests were run in order to determine the usefulness of the factor analysis. A compromise solution was used to select the number of factors based on the percentage of variance explained (~80%) combined with screen plot information. Different rotation methods were attempted and the oblique rotation method was chosen to better achieve well-defined factors.

Results

A total of 168 measurements were made of each of the variables studied. Half of the variables correspond to the RH and the other half to T. Figures 4a and 4b show their averages and Figures 4c and 4d show the average differences between the maximum and minimum measurements taken indoors and outdoors.

Hórreo 1 was in an interior location, where it was exposed to the wind; measurements were taken during the summer. There were significant differences between

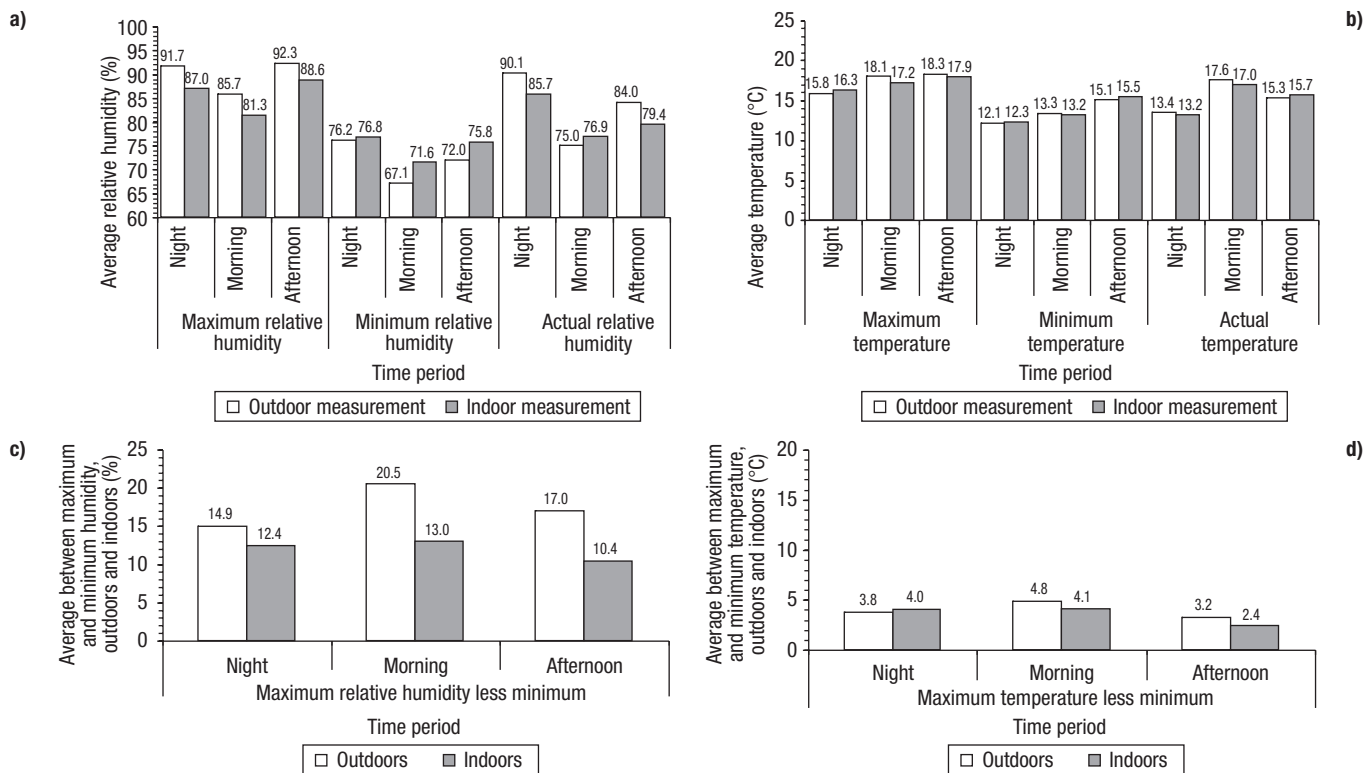

Figure 4. Characteristics of the variables according to time periods of study: a) average relative humidity, b) average temperature, c) average difference between maximum and minimum relative humidity and d) average difference between maximum and minimum temperature.

the maximum relative humidities outside and inside the *hórreo*, based on the Mann-Whitney test, at night ($Z = -3.611, p < 0.05$) and in the morning ($Z = -6.268, p < 0.05$). As regards the minimum RH (RHmin), there was only a significant difference between measurements taken outdoors and indoors at night ($t = 4.243, p < 0.05$).

Hórreo 2 was in a coastal location with normal exposure to the wind; measurements were taken in the autumn. As for the previous *hórreo*, there were significant differences between the maximum RH (RHmax) outdoors and indoors, based on the Mann-Whitney test, at night ($Z = -5.982, p < 0.05$) and in the morning ($Z = -4.036, p < 0.05$). There was significant difference in the afternoon period ($t = -2.661, p = 0.009$). However, there was no significant difference between the RHmin measurements recorded outside and inside the *hórreos* during the different periods.

Hórreo 3 was in an interior location between the mountains and the coast, where it was exposed to the wind; measurements were taken in the autumn. As for the previous *hórreos*, there were significant differences between the RHmax measurements outdoors and indoors based on the Mann-Whitney test, at night ($Z = -5.778, p < 0.05$) and in the morning ($Z = -4.938, p < 0.05$). There were also significant differences in the afternoon between the exterior and interior both for the RHmax ($t = -4.111, p < 0.05$) and for the RHmin ($t = -1.985, p = 0.05$).

There were significant differences between indoor and outdoor RH variation (difference between RHmax and RHmin) in the three studied periods according to Mann-Whitney tests (night $Z = -4.021, p < 0.05$; morning $Z = -4.584, p < 0.05$; and afternoon $Z = -7.174, p < 0.05$).

When analysing the current measurements taken at 9:00, 14:00 and 21:00 hours both inside and outside the *hórreos*, it was observed that the RH_i could be estimated from the outdoor RH (RH_o). The regression line between the current RH_i and current RH_o is given by Equation [1]:

$$y = 0.74 \cdot x + 2.29 \cdot D_1 - 1.93 \cdot D_2 + 19.28 \quad [1]$$

where $y = \text{RH}_i$, $x = \text{RH}_o$ and D_1 and D_2 are dummy variables ($D_1 = 1$ when the measurement was taken at 14:00 and $D_1 = 0$ in other cases; $D_2 = 1$ when the measurement was taken at 21:00 hours and $D_2 = 0$ in other cases).

The coefficients are statistically significant ($t = 44.272, t = 4.614, t = -4.370$ and $t = 12.577$, respectively; $p < 0.05$ in all cases) and the correlation coefficient (coefficient of determination) is $R^2 = 0.827$.

Figure 5 shows the regression lines; in this graph, the effects of the different times at which the current

measurements were taken can be observed. For a specific value of RH_o, the RH inside the *hórreo* was lower at 21:00 than at 9:00 hours and this was lower than at 14:00 hours.

With regard to T, there were no significant differences in any period or *hórreo* between the outdoor minimum T (Tmin) and the indoor Tmin. There were significant differences in the maximum T (Tmax) between outdoor and indoor measurements only in *hórreo* number 1 at night ($t = -2.787, p = 0.006$).

We determined the differences between the maximum and minimum T inside and outside the *hórreos* in each of the time periods and compared them. There were significant differences between the outdoor T (T_o) and indoor T (T_i) in the morning and afternoon periods based on the Mann-Whitney test (morning $Z = -4.454, p = 0.014$; afternoon $Z = -4.853, p < 0.05$).

By analysing the current T measurements both inside and outside the *hórreos*, it was possible to estimate T_i from the data obtained outdoors. The regression line for the relation between the T_s measured inside and outside the *hórreos* is shown in Equation [2]:

$$y = 0.95 \cdot x + 0.94 \cdot D_1 - 0.80 \cdot D_2 + 1.17 \quad [2]$$

where $y = T_i$, $x = T_o$ and D_1 and D_2 are dummy variables ($D_1 = 1$ when the measurement is made at 16:00 and $D_1 = 0$ in other cases; $D_2 = 1$ when the measurement is performed at 9:00 hours and $D_2 = 0$ in other cases).

The coefficients are statistically significant ($t = 95.612, t = -9.028, t = -7.794$ and $t = 6.961$, respectively).

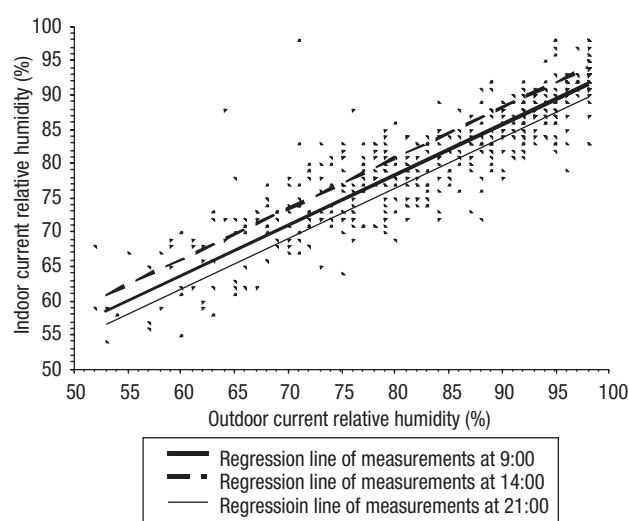

Figure 5. Linear regression between the outdoor and indoor actual measurements of relative humidity.

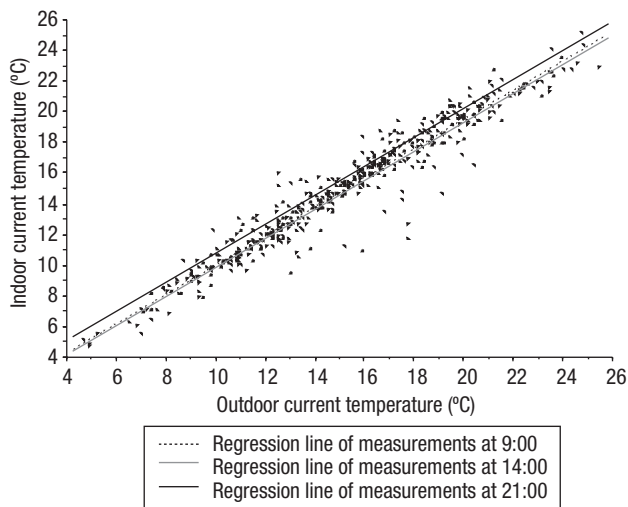

Figure 6. Linear regression between the outdoor and indoor actual measurements of temperature.

vely; $p < 0.05$ in all cases) and the regression coefficient is $R^2 = 0.955$.

Figure 6 shows the regression lines where the effect of the time at which the measurement was taken can be observed. For a specific value of T_o , the value of the T reached inside the *hórreo* was lower when the measurement was performed at 21:00 than when it was performed at 14:00 or 9:00. The T s inside the *hórreo* were practically the same at 9:00 and 14:00.

Two T-RH graphs for two 24-hour measurement periods are shown in Figure 7; they were randomly chosen from among the graphs available. The *hórreos'* moderating effect on indoor air conditions is noticeable at both low (Fig. 7a) and high (Fig. 7b) RHo.

The previous results showed that the building characteristics of *hórreos* influenced the maintenance of

indoor environmental parameters; however, the magnitudes of the differences between the inside and outside environment were variable. Owing to the fact that the building features of *hórreos* were similar while their geographic and topographic conditions differed, the analysis must take into account the influences of the *hórreos'* geographic and topographic features. These features were geographic location, topographic altitude, degree of exposure to the wind and the direction of the building's longitudinal axis; they are shown in Table 1.

The differences between indoor and outdoor T and RH measurements were quantified. Nine T and nine RH variables (for the three types of measurements, maximum, minimum and current; and for the three time periods, night, morning and afternoon) were analysed. A factor analysis was used to determine the existence of homogeneous groups of closely correlated variables.

In the case of T differences, five components were identified, accounting for approximately 83% of the total variance (Table 2). The weights of each of these factors are very similar.

In the case of the RH difference, four components were identified, accounting for approximately 80% of the total variance (Table 2). Two factors accounted for approximately 60% of the variance; this reveals the existence of groups of correlated variables when the differences between outdoor and indoor measurements are studied.

Discussion

Hórreos have traditionally been used successfully for drying and storage of cereal grains, in this case mai-

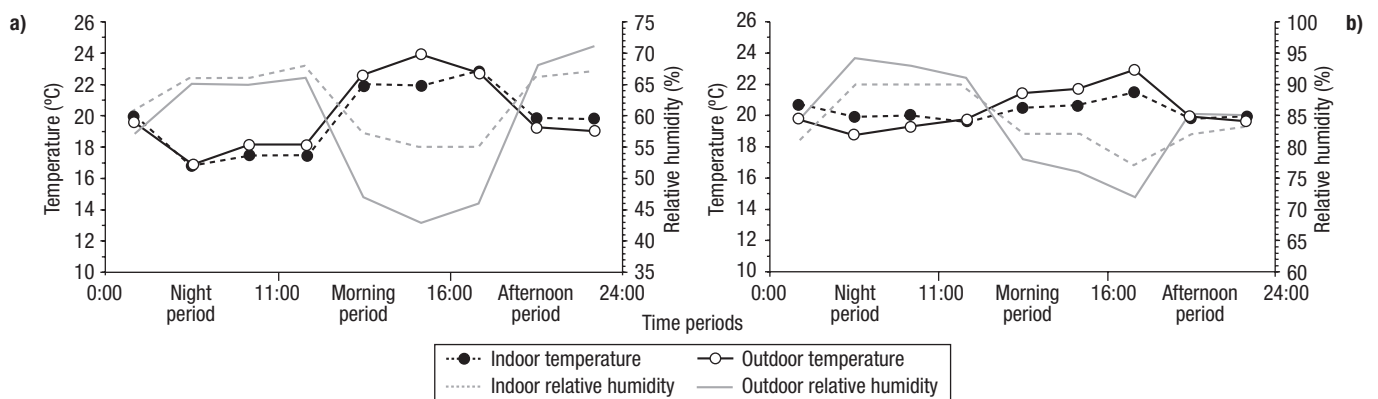

Figure 7. Example of the damping effect of the *hórreo* on environmental conditions of indoor air: a) low and b) high outdoor relative humidity. Graphs are shown for two 24-hour periods.

Table 2. Factor analysis of the temperature and relative humidity differences between outdoor and indoor air (oblique rotated factor matrix, n = 168)

	Factor loadings					Communality	Mean score
	1	2	3	4	5		
<i>Items of temperature</i>							
t_d_m_max	0.86	-0.03	-0.10	-0.03	-0.10	0.78	0.85 ± 0.89
t_d_m_c	0.85	-0.17	0.20	0.15	0.17	0.78	0.61 ± 0.93
t_d_a_max	0.61	0.36	-0.25	-0.34	-0.12	0.77	0.42 ± 0.70
t_d_a_c	-0.15	0.92	-0.01	-0.11	0.09	0.88	-0.47 ± 0.62
t_d_a_min	0.06	0.81	0.16	0.35	0.04	0.83	-0.41 ± 0.69
t_d_n_c	0.01	-0.04	-0.91	0.06	-0.03	0.82	0.26 ± 0.74
t_d_m_min	-0.03	-0.07	-0.88	0.10	0.15	0.80	0.18 ± 0.76
t_d_n_max	0.03	0.11	-0.18	0.91	-0.08	0.86	-0.39 ± 1.29
t_d_n_min	0.03	0.10	-0.11	-0.09	0.96	0.96	-0.20 ± 0.41
% of variance	22.94	20.25	17.78	12.09	9.95	83.03	
<i>Items of relative humidity</i>							
rh_d_n_min	0.90	0.00	-0.08	-0.13		0.72	2.72 ± 5.16
rh_d_n_c	0.78	-0.02	0.02	0.27		0.81	4.25 ± 4.99
rh_d_m_max	0.67	0.09	0.26	0.07		0.72	3.52 ± 3.49
rh_d_m_c	-0.05	0.93	0.04	-0.06		0.85	-2.02 ± 5.51
rh_d_m_min	0.04	0.92	-0.04	-0.02		0.85	-3.69 ± 5.99
rh_d_a_min	0.00	0.80	-0.01	0.06		0.65	-2.15 ± 6.08
rh_d_a_max	-0.03	-0.03	0.95	-0.04		0.86	4.57 ± 4.10
rh_d_a_c	0.04	0.02	0.90	0.02		0.84	4.61 ± 3.85
rh_d_n_max	0.01	0.00	-0.11	0.98		0.96	5.24 ± 3.51
% of variance	36.63	21.64	13.80	8.64		80.70	

Item abbreviations: t, temperature; rh, relative humidity; d, difference between the outdoor measurement and the indoor measurement; m, morning period; a, afternoon period; n, night period; c, current measurement; max, maximum measurement in the period; min, minimum measurement in the period.

ze. Technical recommendations for this cereal suggest that to reduce its moisture content from around 24% to preserving values of around 12 to 14%, it is necessary that the grain be exposed to air with a RH between 60 and 75%. Across RH intervals of $RH \leq 60\%$, $60\% < RH \leq 75\%$, $75\% < RH \leq 85\%$ and $85\% < RH \leq 100\%$, variation was observed in the percentages of measurements within each interval that were favourable for the storage of maize. For outdoor measurements, the interval $85\% < RH \leq 100\%$ represented 50.21% of all of them, the interval $75\% < RH \leq 85\%$ 19.44% and the interval $60\% < RH \leq 75\%$ 23.41%. For the measurements inside the *hórreos*, the percentage of the highest interval decreased and the percentages of the others increased (36.54%, 32.46% and 26.86%, respectively).

Figures 4a and 4b show the average values of the variables. Note that if the RHo was high, the indoor humidity was lower and vice versa. The maximum RHo decreased from 3.7 to 4.7% inside the *hórreo* and the minimum rose from 0.7 to 4.5% depending on the time

period. The T variation was less marked and was in the range of 0.1-0.9°C.

The variation of the RH indicates a softening effect of *hórreos* on the conditions of the outdoor air entering the building. The highest and lowest outdoor values were smoothed indoors. When the RHo was greater than or equal to 90%, the RH_i was, on average, 5.2% lower. If the RHo was less than or equal to 65%, the indoor humidity was, on average, 3.2% higher. This effect diminished as the outdoor humidity approached the mean. When the RHo was around 75%, this effect was smallest and it increased in magnitude when the humidity deviated from this value.

The analysis of RH in each of the *hórreos* for each measurement type (maximum, minimum and current) and time period (night, morning and afternoon) showed that the three *hórreos* behaved similarly. The maximum relative humidities indoors and outdoors were significantly different for most of the time periods, while the minima were not, except in one case.

Figure 4c shows the average of the differences between the maximum and minimum RH indoors and outdoors. The analysis of these differences for each variable and time period revealed significant differences between the outdoor and the indoor measurements in all cases. The difference between the maximum and minimum RH indoors was, on average, 5.4% smaller than the difference outdoors. Therefore, the fluctuations in RH inside the *hórreos* were smaller than they were outside.

The current RH_i was highly correlated with the current RH_o. Figure 5 shows the regression lines, from which the effect of the time period in which the measurement was made can be seen. With regard to the RH outdoors, the RH_i was lower at 9:00 and at 21:00. This suggests again that inside the *hórreo* there was a buffering effect of variations of external RH. This effect could be held to natural ventilation; according to Lomas (2007) geometric design is one of the processes by which natural ventilation can be guaranteed. For example, roof features are important (Özdeniz and Hançer, 2005) and can be used for maintaining appropriate ambient conditions, such as humidity (Abaza, 2005). Nantka (2006) explains that traditional structures that allow natural ventilation can be used in the design of new buildings or in the restoration of existing ones.

With regard to T, there were no remarkable differences between indoor and outdoor values measured in the *hórreos*. Figures 4b and 4d show the average T and the average of the differences between the maximum and minimum T indoors and outdoors. It was noted that the variations were smaller for T than in the case of RH.

There was no significant difference between the indoor and outdoor maximum or minimum Ts for any period, except for the T_{max} of *hórreo* number 1 at night.

As for the difference between maximum and minimum Ts indoors and outdoors, it was found that the variation differed significantly between the inside and outside during the morning and afternoon, but not at night.

The current T_i of the *hórreo* also showed a high correlation with the current T_o. Figure 6 shows the regression lines for the different time periods. The greater slopes of these lines in relation to those for RH indicate the similarity between indoor and outdoor T.

A buffering effect of the *hórreo* on T can also be considered, but to a lesser extent than in the case of RH. The stack effect due to temperature and wind pressure are two of the main factors that, also combined with the design of the building, guarantee natural ventilation (Khan *et al.*, 2008; Larsen and Heiselberg,

2008). In this study, the effect of temperature is less relevant.

Because of their configuration, *hórreos* are effective buildings for RH and T control. Inside, oscillations of RH are damped and, to a lesser extent, oscillations of T are also damped. In conclusion, it can be noted that these two parameters remain more stable within the studied *hórreos* than outside of them.

Because the construction characteristics of the studied *hórreos* were similar and they were empty, this study can be extended by analysing the environmental parameters in *hórreos* with different amounts of grain inside. Considering that the building materials themselves can influence buildings' thermal performance (Parra-Saldivar and Batty, 2006), it can also be extended to *hórreos* built with other materials (for example, entirely of stone).

Once the influences of the construction characteristics on environmental parameters were determined, the final part of the analysis was to determine whether any factor could explain the variability of these parameters. These factors may be related to the differences between the studied *hórreos* related to geographical and topographical characteristics (*i.e.*, geographical location, topographic altitude, degree of exposure to the wind and the direction of the building's longitudinal axis). These factors could be considered as outdoor air factors that can also be taken into account to evaluate the potential for natural ventilation (Germano and Roulette, 2006) such as the wind's incidence angle (Larsen and Heiselberg, 2008). The evaluation of ventilation together with other factors, like the outdoor air characteristics, allows to predict the energy and hygrothermal performance of buildings (Freire *et al.*, 2008) or assess their energy efficiency (Tzikopoulos *et al.*, 2005).

The factor analysis of the difference between indoor and outdoor T identified five components (explaining 83% of the total variance, Table 2), but the weights of each are very similar and no clear interpretation can be made. This suggests that the influences of the various above-mentioned conditions were minimal for all of the T measurements taken (maximum, minimum and current) and for all time periods.

In the case of RH, the factor analysis identified two components (explaining 60% of the total variance, Table 2). Factor 1 represents low-humidity conditions at night (*i.e.*, during low T) and has the greatest weight (36.6%). Factor 2 represents conditions of low diurnal humidity (*i.e.*, during medium and high T) and has a lesser weight (21.6%).

The building configurations of *hórreos* create significant differences in the indoor conditions relative to the outdoor ones. When the humidity is high, the influence of geographic and topographic conditions on the magnitudes of these differences is minimal. That is, inside the *hórreos*, there is a similar reduction of the outdoor RH_{max}. By contrast, the factors described are indicative of the fact that the RH_{min} reached inside the *hórreo* does not depend only on its constructive characteristics. The dissimilar features of the studied *hórreos* in terms of their geographic and topographic conditions could be the origin of the existence of these factors. Consequently, the magnitude of the variation of RH_{min} inside the *hórreo* with respect to the outdoor humidity is also conditioned by the geographic location, topographic altitude, degree of exposure to the wind and direction of the building's longitudinal axis. In order to be able to establish more precisely the nature of the variation that can cause geographic and topographic conditions of *hórreos* to affect the indoor air, a more detailed study is necessary.

Acknowledgements

The authors thank the *hórreos*' owners for allowing access to the buildings studied in this paper.

References

- ABAZA H.F., 2005. Utilizing latent building thermal mass for dehumidification. *J Build Phys* 29, 37-49.
- CHEN Q.G., FENG Y., WANG G.L., 1997. Healthy buildings have existed in China since ancient times. *Indoor Built Environ* 6, 179-187.
- COX P.D., COLLINS L.E., 2002. Factors affecting the behaviour of beetle pests in stored grain, with particular reference to the development of lures. *J Stored Prod Res* 38, 95-115.
- DE-LLANO P., 1983. *Arquitectura popular en Galicia Vol 2*. COAG, Colegio Oficial de Arquitectos de Galicia, Santiago de Compostela, Spain. 445 pp. [In Galician].
- FREIRE R.Z., OLIVEIRA G.H.C., MENDES N., 2008. Development of regression equations for predicting energy and hygrothermal performance of buildings. *Energ Buildings* 40, 810-820.
- GAGIU V., AVRAM M., IORGA E., BELC N., DIACONU M., DIACONU A., PRICOP M., 2007. Microbial and mycotoxin contamination of maize during storage. *Romanian Biotechnological Letters* 12, 3389-3394.
- GERMANO M., ROULET C.A., 2006. Multicriteria assessment of natural ventilation potential. *Sol Energy* 80, 393-401.
- KHAN N., SU Y.H., RIFFAT S.B., 2008. A review on wind driven ventilation techniques. *Energ Buildings* 40, 1586-1604.
- LARSEN T.S., HEISELBERG P., 2008. Single-sided natural ventilation driven by wind pressure and temperature difference. *Energ Buildings* 40, 1031-1040.
- LOMAS K.J., 2007. Architectural design of an advanced naturally ventilated building form. *Energ Buildings* 39, 166-181.
- MAGAN N., LACEY J., 1988. Ecological determinants of mold growth in stored grain. *Int J Food Microbiol* 7, 245-256.
- MARTÍNEZ-RODRÍGUEZ I., 1999. *El hórreo gallego*, 2nd ed. Fundación Pedro Barrié de la Maza, A Coruña, Spain. 443 pp. [in Spanish].
- NANTKA M.B., 2006. Indoor conditions in Silesian buildings with natural ventilation. *Indoor Built Environ* 15, 571-182.
- OKTAY D., 2002. Design with the climate in housing environments: an analysis in Northern Cyprus. *Build Environ* 37, 1003-1012.
- ÖZDENİZ M.B., HANÇER P., 2005. Suitable roof constructions for warm climates-Gazima usa case. *Energ Buildings* 37, 643-649.
- PARRA-SALDIVAR M.L., BATTY W., 2006. Thermal behaviour of adobe constructions. *Build Environ* 41, 1892-1904.
- PHILLIPS T.W., THRONE J.E., 2010. Biorational approaches to managing stored-products insects. *Annu Rev Entomol* 55, 375-397.
- ROZMAN V., LISKA A., VOLENIK M., KALINOVIC I., SIMIC B., 2008. Influence of relative humidity and temperature to the changes in grain temperature in stored wheat and maize. *Proc IV Int Congress on Flour-Bread*. Opatija, Croatia, Oct 24-27. pp. 135-141.
- SOZEN M.S., GEDIK G.Z., 2007. Evaluation of traditional architecture in terms of building physics: old Diyarbakir houses. *Build Environ* 42, 1810-1816.
- TZIKOPOULOS A.F., KARATZA M.C., PARAVANTIS J.A., 2005. Modeling energy efficiency of bioclimatic buildings. *Energ Buildings* 37, 529-544.
- VAN HOOFF J., VAN DIJKEN F., 2008. The historical turf farms of Iceland: Architecture, building technology and the indoor environment. *Build Environ* 43, 1023-1030.
- WHITE N.D.G., 1992. Multidisciplinary approach to stored-grain research. *J Stored Prod Res* 28, 127-137.
- YIGEZU Y.A., ALEXANDER C.E., PRECKEL P.V., MAIER D.E., WOLOSHUK C.P., MASON L.J., LAWRENCE J., MOOG D.J., 2008. Optimal management of molds in stored corn. *Agr Syst* 98, 220-227.