



Implementation of a 3.5 kW resistive load bank for a single-cylinder diesel engine test bench

Implementación de un banco de carga resistivo de 3.5 kW para un banco de prueba de motor Diésel monocilíndrico

M. Celis-Quintero ; G. Hernández-Acosta ; J. Duarte-Forero 

DOI: <https://doi.org/10.22517/23447214.22881>

Artículo de investigación científica y tecnológica.

Abstract— This article presents the implementation of a 3.5 kW resistive load bank applied to a four-stroke single-cylinder diesel engine test bench that operates with an alternator. With this experimental test bench, it is possible to perform mechanical, thermodynamic, and polluting emissions studies in compression-ignited or induced internal combustion engines. Applying the quantitative research methodology, the design of the electric charging system is carried out. Power control circuits and safety elements are designed for the load bank. CAD software is used to design the structure and casing considering anthropometric measurements. Also, finite element analysis (FEA) is incorporated to verify the structural and thermal design criteria. The implementation of an electrical and instrumentation acceleration system for sensing power and torque in low-displacement engines showed a measurement error of less than 1%. Similarly, the FEA allowed to quantify the maximum efforts and guarantee a safety factor above 5. With the characterization of the implemented sensors, a correlation coefficient of up to 99.97% was achieved. The power measurement displayed an error lower than 3%, which leads to a high characterization capacity of any thermal machine with equal power or less than the designed one.

Index Terms— Characterization, Engine, Finite elements, Resistive load bank, Power, and torque sensors.

Resumen— En este artículo se presenta la implementación de un banco de carga resistivo de 3.5 kW aplicado a un banco de prueba de motor Diesel monocilíndrico cuatro tiempos acoplado a un alternador. Con este banco de prueba experimental, es posible realizar el estudio mecánico, termodinámico y de emisiones contaminantes en motores de combustión interna de encendido por compresión o provocado. Aplicando la metodología de investigación cuantitativa se lleva a cabo el diseño del sistema de carga eléctrico, y los circuitos de control de potencia con sus elementos de seguridad, y mediante un software CAD se crea la estructura y carcasa basados en medidas antropométricas, aplicándole un estudio de esfuerzo mecánico sobre las piezas

diseñadas a través de un análisis de elementos finitos (AEF). Se detalla el desarrollo de un sistema de aceleración eléctrico y de instrumentación para el sensado de potencia y torque en motores de baja cilindrada, con un error de medición menor al 1%. De igual forma, el AFE permitió cuantificar los esfuerzos máximos y garantizar un factor de seguridad por encima de 5. Con la caracterización de los sensores implementados, se logró un coeficiente de correlación de hasta 99.97%, y en la medida de potencia un error inferior al 3%, lo que conlleva a una alta capacidad de caracterización de cualquier máquina térmica con una potencia igual o menor a la de diseño.

Palabras claves— Banco de carga resistivo, Caracterización, Elementos Finitos, Motor, Sensores de potencia y torque.

I. INTRODUCTION

GENSET engines are extensively implemented for electric power generation, especially for non-interconnected areas. This technology is becoming of increasing interest due to the imminent necessity to reduce fuel consumption while maintaining optimal thermo-mechanical performance [1]. Specifically, energy fluctuations account for a significant reduction in the overall efficiency. Hence, different experimental assessments center on the characterization of the operating load by incorporating a so-called load bank. The latter is a piece of equipment that emulates the load experienced by the Genset using electrical charge blocks. This analysis takes relevance since it stands as a robust tool to evaluate the overall behavior of Gensets based on the operating load, which further contributes to set up maintenance actions and evaluate system improvements [2], [3].

In this sense, a motor-generator set can be implemented as a didactic way to investigate the main features of operation in an engine test bench. Internal combustion engines (ICE) convert chemical energy into mechanical power through a combustion process. The load condition is determined by the energy

This manuscript was sent on August 31, 2019 and accepted on November 23, 2020.

Miguel Celis Quintero is with Universidad del Atlántico, Mechanical Engineering Program, Puerto Colombia, Colombia (e-mail: mcelis@mail.uniatlantico.edu.co).

Gabriel Hernández Acosta is with Universidad del Atlántico, Mechanical Engineering Program, Puerto Colombia, Colombia (e-mail: gjosehernandez@mail.uniatlantico.edu.co).

Jorge Duarte Forero is with Universidad del Atlántico, Mechanical Engineering Program, Puerto Colombia, Colombia (e-mail: jorgeduarte@mail.uniatlantico.edu.co).



demand that the Genet should provide that, in other words, can be expressed as the required force that needs to be generated from combustion. The load condition becomes vital since it determines, to a great extent, the fuel consumption and the thermo-mechanical behavior of the engine [4]-[6]. Additionally, implementing a load bank allows evaluating the influence of the load rate on the feasibility of partial fuel substitution technologies such as biofuel blends and hydrogen enrichment [7],[8]. Most of the studies regarding the experimental test bench of diesel engines rarely characterized the construction and implementation of the load bank, despite being important equipment of the experimental layout. Also, the instrumentation and control features remain unexplored. This investigation is driven to fill the knowledge gap about this matter by incorporating detailed criteria for structural design as well as instrumentation and control strategies.

Specifically, a load bank for alternating current (AC) power tests can be divided into resistive and reactive. Also, the combination of the last two can be implemented in a test bench. Taking into account that the power factor is a direct measure of the fuel conversion efficiency, it should be noted that the reactive loads lead to a decrease in the power factor [9]-[11].

On the other hand, resistive banks highlights for consuming active power, which is independent of the electric frequency. The latter is a significant advantage of this type of load bank since it maintains a unit power factor [12]-[14]. In a Genset, the frequency of the voltage delivered to the system is directly related to the rotational speed of the engine and the number of poles of the generator. Therefore, when the electromagnetic torque increases, it produces a reduction of the rotational speed of the engine, which leads to frequency fluctuations. To maintain the aforementioned condition within limits, it is necessary to control the power generated and the electric charge demand [15]-[17]. Thus, it is evident that the construction of a load bank requires a major effort to enable control on the operating conditions of the engine tested, whereas other important features such as compactness, safeness, and reliability should be met to provide robust equipment that facilitates research in ICEs.

This investigation presents the main features of the construction and implementation of a load bank as didactic and functional equipment that reinforce experimental testing in diesel engines. The incorporation of CFD tools to evaluate both thermal and structural characteristic of the proposal stand as differential factors from former research. Thus, this work contributes to close the knowledge gap regarding the construction criteria of load banks for integration in an experimental engine setup.

II. RESISTIVE LOAD BANK TESTING DESIGN

For the design of the equipment, the internal elements are sized before construction to estimate the structural requirements.

A. Design of the resistive load system

The following limitations are considered for the design of the

resistive load:

- Total load: the maximum electric power delivered by the engine test bench is set as the reference. It is worth mentioning that the device must work with two identical engine test benches simultaneously.
- Ability to modulate the load: divide the total load into smaller packages.
- Operating temperature: the temperature of the resistive assembly must guarantee safe operation.

The main characteristics and electrical parameters of the Genset are specified in Table I.

TABLE I
GENSET ELECTRICAL PARAMETERS.

Variable	Magnitude	Unit
Max power	3500	W
Nominal Voltage	120/240	VAC
Maximum Intensity	29.2	A

Ohm's law is the total resistance that the load circuit must have (Eq. 1).

$$R = \frac{V}{I} = \frac{120}{29.2} = 4.109 \quad (1)$$

The total resistance is rounded to 4 ohms in order to simplify the calculations. There are several types of resistance in the market, but a multi-criteria evaluation is done between two types of most common resistance. According to the multi-criteria assessment, the resistance that best meets the requirements is the 30 cm cartridge resistance with ½ in. A parallel circuit is then configured such that small load packages can be joined until the desired power consumption is reached as shown in Table II.

TABLE II
DETERMINATION OF ELECTRICAL PARAMETERS FOR CIRCUIT CONFIGURATION.

Tension (VAC)	Intensity (A)	Resistance (Ω)
120	2.82	42.5
Package	Equivalent	
	(A)	(W)
1	2.82	337.98
2	5.64	675.95
3	8.46	1013.93
4	11.28	1351.91
5	14.1	1689.89
6	16.92	2027.86
7	19.74	2365.84
8	22.56	2703.82
9	28.2	3379.77
10	33.84	4055.72
		42.5

According to the size of the resistances and the tube bank configuration requirement, a rectangular duct is designed in a 22-gauge galvanized steel sheet. The material is not affected by the temperature of the resistances since it is isolated internally with refractory ceramic plates. The final assembly is presented in Fig. 1.

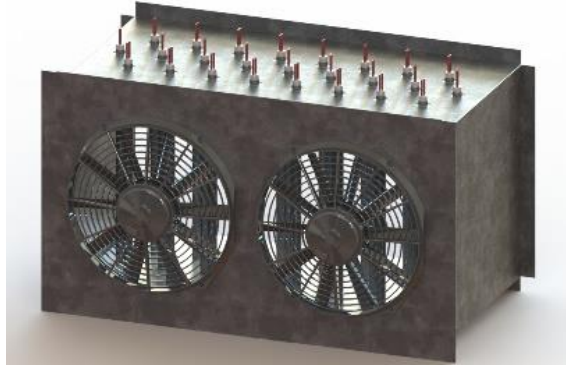

Fig. 1. Schematic representation of the resistive load duct.

A fan is selected as the cooling mechanism, which operates by enabling airflow to the resistive load duct, thus maintaining a safe temperature and avoiding the concentration of heat inside the system. Axial fans provide different advantages such as high flow rates at low pressures, reduced size, lower energy consumption, and low noise, which make them suitable for cooling the resistive load. An axial fan is selected according to the available space and the availability in the market, and subsequently, the thermal analysis is performed to determine that it meets the requirements (Table III).

TABLE III
CHARACTERISTICS OF THE SELECTED FAN.

VA07-AP12/C-31S	
Type	Soffiante - Blowing
Propeller Diameter	225mm
Tension	12v DC
Static pressure	17.5 mm H ₂ O
Intensity	6.6 A
Airflow	1000 m ³ /h

Thermal analysis is performed in order to ensure sufficient heat transfer with the mass flow provided by the fans. For this analysis, the maximum power at which the bank can operate is considered. A surface temperature of the resistances and steady-state conditions are assumed. The effects of radiation are neglected. Accordingly, Table IV summarized the operational conditions of the thermal analysis, and Fig. 2 displays the CFD simulation results.

TABLE IV
GEOMETRIC PROPERTIES OF THE HEATING ELEMENT AND TUBE BANK.

Variable	Value	Symbol	Unit
Temp. superficial assumed	380	T _s	°C
Temp. bank entrance	30	T _i	°C
Temp. movie stockin	50	T _m	°C

Input flow rate	2.49	V	m/s
Outlet temperature	76.87	T _e	°C
Total surface area	0.34	A _{st}	m ²
Reason for heat transfer	7.39 x 10 ³	Q	W
Resistance heat transfer reason	7.20 x 10 ³	Q _R	W
Error rate	2.64	E _R	%
Pressure drop	13.21	ΔP	Pa
Static Fan Pressure	24.52	P _s	Pa

According to the results, the mass flow provided by the fans maintained a maximum surface temperature of the resistive elements of 76 °C, which guarantees their integrity. Thermal flow simulation provides valuable information about the temperature gradients in the equipment.

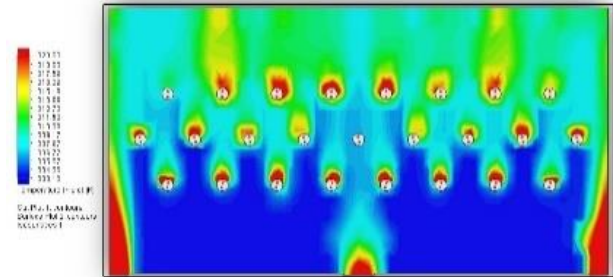

Fig. 2. CFD simulation of the load duct - top view.

B. Power control circuit

The design of this circuit includes all the necessary elements to ensure the secure handling of the electric fluid that comes from the GE alternator. The power control circuit has two operation modes to account for changes in the power required by the load bank, making the device didactic.

The first operation mode corresponds to the stepped power control that allows power variations in so-called steps, meaning adding load packages. The second mode is the gradual control, which enables power variations by the phase control of the electronic circuit that operates with the delay angle time of the AC wave propagation. Fig. 3 displays a basic scheme of the general circuit for power control.

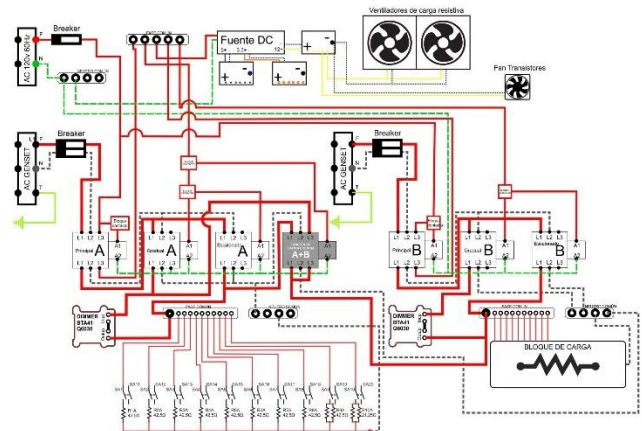

Fig. 3. Scheme of the power control circuit. Load bank instrumentation system

The load bank instrumentation enables data acquisition of engine parameters such as torque and power. Taking into account that the power factor is unitary, a device is designed to measure the electrical power, which adjusts to the mechanical power using the engine's efficiency. This device consists of a non-invasive inductive current transformer that operates on the Faraday induction principle, sending a low AC signal to a signal conditioning circuit that rectifies it by converting it into DC (direct current). This signal is read by an Arduino® data acquisition card (DAQ) to encode it for signal processing and finally display the power values on a digital screen.

The signal conditioning circuit is shown in Figure 4. MC33202 rail-to-rail operational amplifiers are employed since they are stable and little affected by noise.

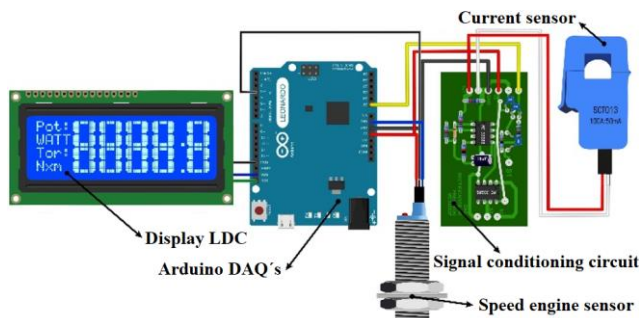

Fig. 4. Assembly diagram for power and torque meter.

The current sensor is characterized to check the linear behavior indicated by the manufacturer as shown in Table V. Eq. 2 presents the linear behavior of a curve which is verified in Fig. 5.

$$y = a + bx \tag{2}$$

TABLE V
LINEAR REGRESSION ANALYSIS OF SENSOR SCT013-050.

Determination Coefficient	R ²	99.9735 %
Coefficients	a	-16.134
	b	1.7532

To measure the torque, an interrupt sensor that operates with a magnetic field is implemented to vary the voltage in the terminals. These variations are recognized by the DAQ card as an interruption that uses a programming code to relate the angular velocity and the power generated for the torque calculation.

C. Design of the structure

Once the internal components necessary for the development of the device have been established, the design of the structure and housing is carried out. The construction of the load bank is driven to fulfill the specifications listed in Table VI. Therefore, in the process, different design concepts are evaluated as shown in Fig.7 to meet the best layout from different perspectives.

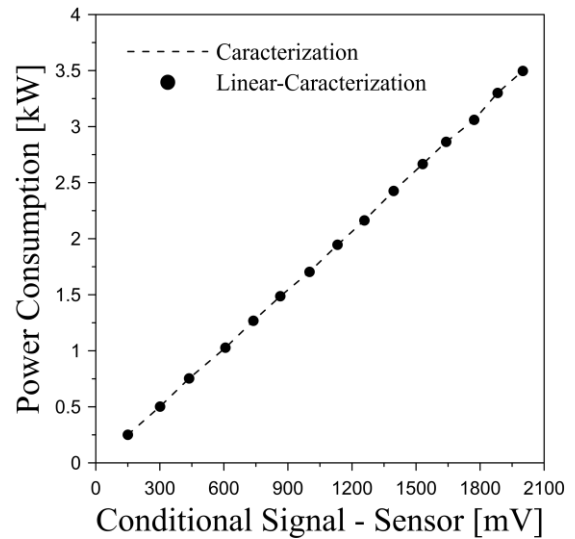

Fig. 5. Characterization curve of the TC sensor SCT013-050.

TABLE VI
MAIN NEEDS OF THE DEVELOPED SYSTEM.

Specification	
1	Contain two 3500W banks that operate independently of each other.
2	Integrate a device for GE acceleration control
3	Integrate a device to control the GE ignition
4	Allow power control gradually
5	Allow data visualization: Electric power

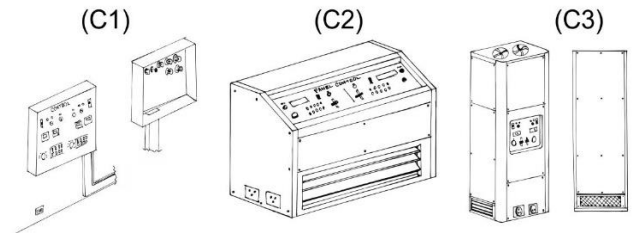

Fig. 6. Design concepts visualization for the load bank.

Based on the system specifications, each of the concepts is evaluated through a CBA chart, (choosing by advantages). In this way, the concept design that best meets the specifications can be selected (Fig. 6).

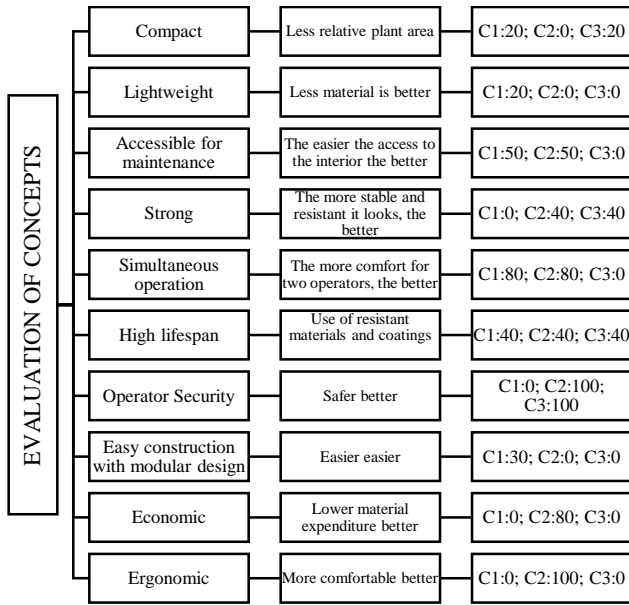

Fig. 7. Hierarchy chart for concept evaluation.

According to the advantage’s selection (Fig. 7), the design concepts outlined a score of C1: 240, C2: 490, C3: 200. Thus, it can be concluded that the concept that best meets the requirements is C2.

Once the design is selected, detailed drawings are made. In order to establish dimensions that allow the development of an ergonomic device, the anthropometric measurements of the young Colombian population between the ages of 20 and 29 are implemented [18], as shown in Fig. 8.

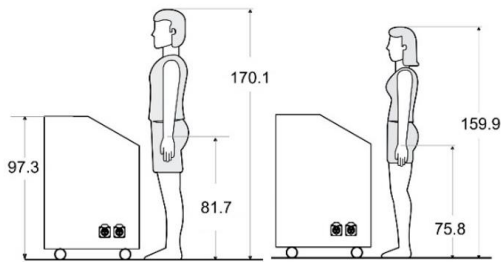

Fig. 8. Anthropometric measurements in centimeters.

Based on the preliminary dimensions of the structure, the parts that make up the housing are conceived. Next, modular design is established so that manufacturing and repair operations can be facilitated. Notice that the design process is iterative and is susceptible to dimensional or structural changes. Fig. 9 shows the rendering of the parts of the housing.

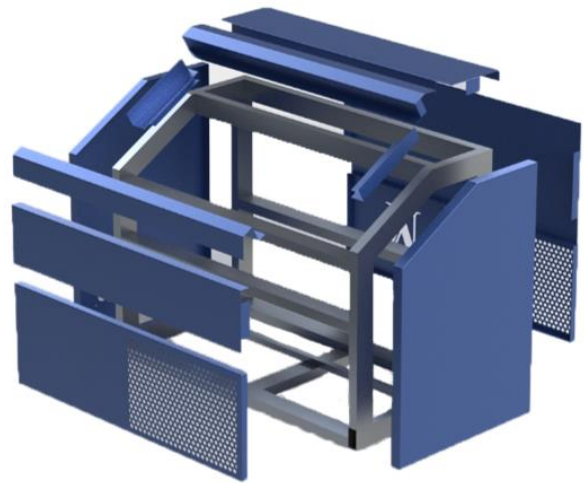

Fig. 9. Exploded visualization of the load bank housing.

Since the structure is the element that supports the weight of internal components and even external elements, a CFD study is required to verify the structural integrity by considering mechanical and physical characteristics. The following considerations were defined to perform the structural analysis:

- The structure will be treated as a beam, a rigid element, and not as a reinforcement.
- Charges are considered static and uniformly distributed. Thus, alternative loads or vibrations are neglected.
- Static analysis will be carried out to calculate the reactions that further assist the subsequent design of the structural supports.
- For the load calculation, the total weight of the internal components and housing are considered. An extra charge such as the weight of a person or an item that can be placed on top of the bank is added to account for a security factor [19]
- The support points are placed in the area that covers the base of the wheels.

The lateral structure is one of the most relevant elements for the design since it supports a great extent of the total load. Therefore, it becomes of major interest in the study. The distributed forces are transferred to the connection points to converted them into point loads.

A specialized finite difference analysis software is implemented to perform a static stress study. The results are shown in Fig. 10.

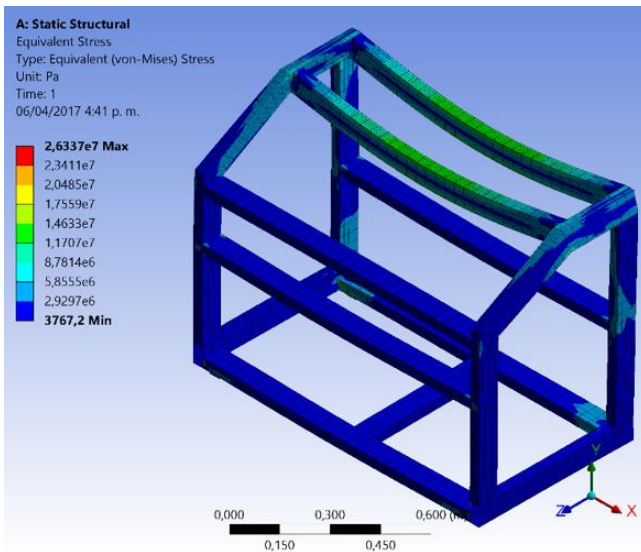

Fig. 10. Analysis of equivalent efforts with finite differences.

According to the results, it can be verified a high safety factor in the design, which can be explained from an oversized profile selection. However, based on commercial, aesthetic, and functional reasons, the body or carcass support required the selected profile.

D. Control panel design

The main control panel is an important part of the design of the load bank since it contains all the necessary controls for device handling. In addition, the panel included diagrams and necessary indications for didactic purposes that facilitate understanding and manipulation (Fig. 11). This piece is vital in the equipment since it communicates with the operator and the machine. Therefore, it must have a careful design regarding the location of the controls and quick operation actions in case of an emergency. The control panel houses the control of two load banks that, despite being integrated into the same device, operate independently. The nomenclature of each bank is A and B, respectively.



Fig. 11. Main control panel of the load bank.

III. TESTS AND DEVELOPMENT

Using the CAD design tool, SolidWorks® renders renderings on the final design of the bank in order to have a preview of what the load bank will be, as shown in Fig. 12.

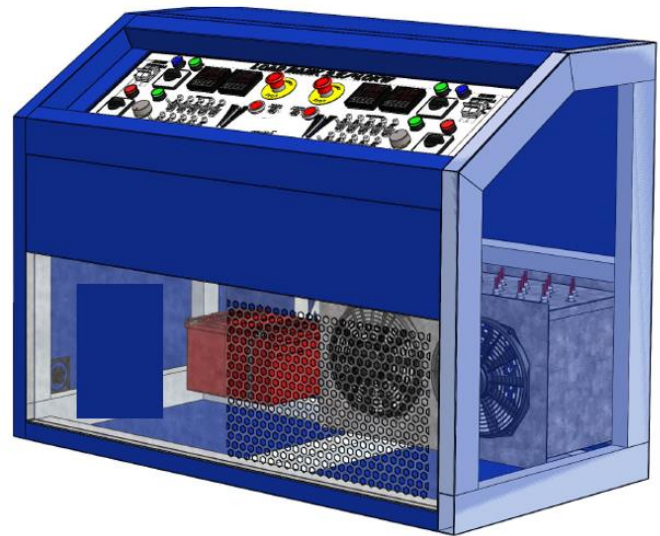

Fig. 12. Detail visualization of the load bank.

Functional tests of the load bank are carried out together with the engine test bench to derive the characteristic curves. Table VII displays the main specifications of the engine tested. Figure 13 presents the comparison between the manufacturer's curve and the one obtained from experimental assessments.

TABLE VII
SPECIFICATIONS OF THE TEST ENGINE

Engine type	Single - cylinder
Manufacturer	SOKAN
Model	SK-MDF300
Cycle	4 - Stroke
Bore x stroke	78 mm x 62.57 mm
Displaced volume	299 CC
Compression ratio	20:1
Maximum power	4.6 hp to 3600 rpm
Intake system	Naturally aspirated
Injection system	Direct injection
Injection Angle	20° BTDC

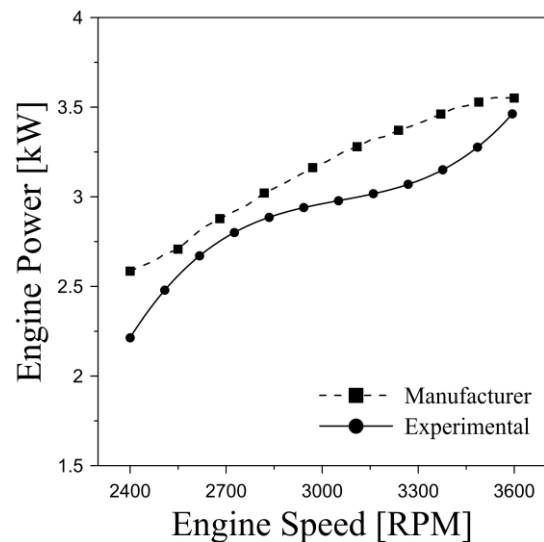

Fig. 13. Validation of the characteristic curve of the engine.

According to the results, it can be verified the satisfactory agreement between the manufacturer and experimental curves, with a relative error of less than 6%. Thus, the characterization curves of the engine are validated.

IV. CONCLUSIONS

The present investigation outlined the construction and implementation characteristics of a resistive load bank as a didactic tool that contributes to characterize thermal machines. The study incorporated CFD tools to facilitate design criteria from structural and thermal concepts, which represent unique aspects of the present investigation. The methodology implemented in the present study presents a detailed explanation of the evaluation procedure of different design concepts. CAD design software is used to sketch the conceptual designs and supplementary materials such as fans and instrumentation elements.

The final product stands as a robust tool that reinforces investigative purposes since load variations and engine control provides valuable output data to evaluate different technologies such as partial fuel substitution and biodiesel blends. Specifically, to obtain power and torque data from the ICE, it is necessary to set the load factor as unitary, which is only achieved with a purely resistive electrical load. Hence, the circuits were designed to enable control of the electric fluid supplied by the Genset

An in-house device was developed for the measurement of non-invasive alternating current intensity that operates with signal conditioning and data acquisition cards to obtain a characteristic equation that relates the current intensity to the mechanical power. An engine speed measurement system was developed to complement the mechanical power sensor measure and finally obtain the torque experienced by the Genset.

The final product of the load bank was validated with the manufacturer's data. Therefore, the characteristic curve that relates both engine power and speed was obtained experimentally with a relative error of less than 6%, which demonstrates reliability in the calculations.

The results indicated that the incorporation of an electronic throttle enables stable engine revolutions in the engine. In conclusion, the load bank allows easy, comfortable, and safe operation either for academic or investigative purposes. The methodology displayed is illustrative and can be used as a reference for similar implementations for the design of electromechanical systems.

Nomenclature

Symbol	Name	Unit
AC	Alternating current	-
CAD	Computer-aided design	-
CBA	Choosing by advantages	-
CFD	Computational fluid dynamics	-
DC	Direct Current	-
Genset	Generator set	-
ICE	Internal combustion engine	-
R	Resistance	Ω
I	Current	A
V	Voltage	V

ACKNOWLEDGMENT

The authors would like to thank UNIVERSIDAD DEL ATLÁNTICO and SPHERE ENERGY company for their great support to the development of this investigation.

REFERENCES

- [1] G. Valencia Ochoa, C. Acevedo Peñaloza, and J. Duarte Forero, "Combustion and Performance Study of Low-Displacement Compression Ignition Engines Operating with Diesel-Biodiesel Blends," *Applied Sciences*, vol. 10, no. 3, p. 907, 2020. DOI: <https://doi.org/10.3390/app10030907>
- [2] C.A. Romero, R. Acosta, and J. Lopez, "The Status of Experimental Investigations on the use of LPG for Generator Sets in Colombia," *SAE Technical Paper*, No. 2016-01-0880, 2016. DOI: <https://doi.org/10.4271/2016-01-0880>
- [3] G.V. Ochoa, J.P. Rojas, and J.D. Forero, "Advance Exergo-Economic Analysis of a Waste Heat Recovery System Using ORC for a Bottoming Natural Gas Engine," *Energies*, vol. 13, no. 1, p. 267, 2020. DOI: <https://doi.org/10.3390/en13010267>
- [4] J. Duarte, N. Duarte Forero, B. Hernandez, M. Vanegas, and R. Stand, "Experimental Study of Partial Fuel Substitution With Hydroxy and Energy Recovery in Low Displacement Compression Ignition Engines," *In ASME International Mechanical Engineering Congress and Exposition*, American Society of Mechanical Engineers, vol. 59452, p. V008T09A021, 2019. DOI: <https://doi.org/10.1115/IMECE2019-10122>
- [5] D.P. Satsangi, and N. Tiwari, "Experimental investigation on combustion, noise, vibrations, performance and emissions characteristics of diesel/n-butanol blends driven Genset engine," *Fuel*, vol. 221, pp. 44-60, 2018. DOI: <https://doi.org/10.1016/j.fuel.2018.02.060>
- [6] C. Ricardo, A. M. Fernando, M. P. Valmir, and C. L. Luciana, "Performance Assessment of Generators Groups When Connected to an Inductive Load," *IEEE Trans. Latin America*, vol. 14, no. 3, pp. 1296-1301, 2016. DOI: <https://doi.org/10.1109/TLA.2016.7459612>
- [7] N. Indrawan, S. Thapa, P.R. Bhoi, R.L. Huhnke, and A. Kumar, "Engine power generation and emission performance of syngas generated from low-density biomass," *Energy Conversion and Management*, vol. 148, pp. 593-603, 2017. DOI: <https://doi.org/10.1016/j.enconman.2017.05.066>
- [8] J. Duarte, W. Orozco, J. González, E. Buelvas, and L. Corredor, "Thermodynamic analysis of self-ignition in spark-ignited engines operated with alternative gaseous fuels," *Tecciencia*, vol. 11, no. 20, pp. 57-65, 2016. DOI: <http://dx.doi.org/10.18180/tecciencia.2016.20.8>
- [9] V. Huchon, F. Pinta, J.M. Commandré, and L. Van De Steene, "How electrical engine power load and feedstock moisture content affect the performance of a fixed bed gasification Genset," *Energy*, vol. 197, p. 117144, 2020. DOI: <https://doi.org/10.1016/j.energy.2020.117144>
- [10] J. Duarte Forero, G. Amador Diaz, J. Garcia Garcia, M. San Juan Mejia, and L. Corredor Martinez, "Application of Mechanisms for the Control of Autoignition in High Power Internal Combustion Engine Fueled With Natural Gas," *In ASME 2013 7th International Conference on Energy Sustainability collocated with the ASME 2013 Heat Transfer Summer*

Conference and the ASME 2013 11th International Conference on Fuel Cell Science, Engineering and Technology. American Society of Mechanical Engineers Digital Collection, ES2013-18023, V001T13A0022013. DOI: <https://doi.org/10.1115/ES2013-18023>

- [11] J.E.D. Forero, W.G. Estrada, and J.S. Guerrero, "Desarrollo de una metodología para la predicción del volumen real en la cámara de combustión de motores diésel utilizando elementos finitos," *INGECUC*, vol. 14, no. 1, pp. 122-132, 2018. DOI: <https://doi.org/10.17981/ingecuc.14.1.2018.11>.
- [12] H.N. Pallares, S.V. Acosta, J.E.D. Forero, and A.R. Montenegro, "Implementación de un banco para pruebas en motor Diésel monocilíndrico con aplicaciones investigativas," *Scientia et Technica*, vol. 22, no. 4, pp. 330-340, 2017. DOI: <http://dx.doi.org/10.22517/23447214.16111>
- [13] M. B. Freddy y R. T. Miller, "Diseño y construcción de un banco de pruebas para motores mono cilíndricos de cuatro tiempos a gasolina," Trabajo de grado, Facultad de Ing. Mecánica, Escuela de ingeniería y administración, Universidad Pontificia Bolivariana, Bucaramanga, Colombia, Jun. 2011.
- [14] G. V. Ochoa, C. Isaza-Roldan, and J.D. Forero, "A phenomenological base semi-physical thermodynamic model for the cylinder and exhaust manifold of a natural gas 2-megawatt four-stroke internal combustion engine," *Heliyon*, vol. 5, no. 10, e02700, 2019. DOI: <https://doi.org/10.1016/j.heliyon.2019.e02700>
- [15] R. Ramírez, A.S. Gutiérrez, J.J.C. Eras, K. Valencia, B. Hernández, and J.D. Forero, "Evaluation of the energy recovery potential of thermoelectric generators in diesel engines," *Journal of Cleaner Production*, vol. 241, p. 118412, 2019. DOI: <https://doi.org/10.1016/j.jclepro.2019.118412>
- [16] G. Valencia Ochoa, C. Acevedo Peñaloza, and J. Duarte Forero, "Thermoeconomic optimization with PSO Algorithm of waste heat recovery systems based on Organic Rankine Cycle system for a natural gas engine," *Energies*, vol. 12, no. 21, p. 4165, 2019. DOI: <https://doi.org/10.3390/en12214165>
- [17] A.K. Agarwal, N. Sharma, A.P. Singh, V. Kumar, D.P. Satsangi, and C. Patel, "Adaptation of Methanol–Dodecanol–Diesel Blend in Diesel Genset Engine," *Journal of Energy Resources Technology*, vol. 141, no. 10, p. 102203, 2019. DOI: <https://doi.org/10.1115/1.4043390>
- [18] C. A. Rosalfo, L. P. Lilia y M. G. Elvia, "Dimensiones antropométricas de población colombiana," *Dimensiones antropométricas de población latinoamericana*, 2ª ed. México: Univ. de Guadalajara, 2007, pp. 197-204. ISBN 978-970-27-1193-3
- [19] Extrudal S.A. (2016, Febrero), "Catalogo de extrusiones de aluminio," Formas y dimensiones normalizadas. [En línea]. Disponible: <http://extrudal.com/cat1.pdf>



Miguel Celis Quintero. Barranquilla native, Received a degree in Mechanical Engineering from Universidad Del Atlántico, located in Barranquilla, Colombia in 2018. ORCID: <https://orcid.org/0000-0001-6776-8899>



Gabriel Hernández Acosta. Barranquilla native, Received a degree in Mechanical Engineering from Universidad Del Atlántico, located in Barranquilla, Colombia in 2018. ORCID: <https://orcid.org/0000-0002-7848-8638>



Jorge Duarte Forero. Barranquilla native, Colombia. He is an associated professor of the Mechanical Engineering Program at Universidad del Atlántico. He received his BSME from Universidad del Atlántico, located in Barranquilla, Colombia in 2007. Master in Mechanical Engineering from Universidad del Norte, Barranquilla, Colombia in 2013. Ph. D in Engineering from Universidad del Norte, Colombia in 2017. He is a COLCIENCIAS – Senior Researcher. ORCID: <https://orcid.org/0000-0001-7345-9590>